



M3G084-GF06-44 ebmpapst Datasheet
sales@fansco.com
www.fansco.com

Limited partnership · Headquarters Muldingen
 County court Stuttgart · HRA 590344

General partner Elektrobau Muldingen GmbH · Headquarters Muldingen
 County court Stuttgart · HRB 590142

Nominal data

Type	M3G084-GF06-44	
Motor	M3G084-GF	
Phase		3~
Nominal voltage	VAC	400
Nominal voltage range	VAC	380 .. 480
Frequency	Hz	50/60
Type of data definition		ml/cu
Speed (rpm)	min ⁻¹	2400
Power input	W	690
Power output	W	580
Current draw	A	1.3
Rated torque	Ncm	230
Min. ambient temperature	°C	-25
Max. ambient temperature	°C	40

ml = Max. load · me = Max. efficiency · fa = Running at free air · cs = Customer specs · cu = Customer unit
 Subject to alterations



Technical features

Mass	7.7 kg
Motor size	84
Material of electronics housing	Die-cast aluminium
Housing material	Die-cast aluminium
Direction of rotation	Clockwise, seen on shaft
Type of protection	IP55
Insulation class	"B"
Humidity (F) / environmental protection class (H)	H2
Max. permissible ambient motor temp. (transp./ storage)	+80 °C
Min. permissible ambient motor temp. (transp./storage)	-40 °C
Mounting position	Any
Cooling bore / aperture	Rotor-side
Operation mode	S1
Motor bearing	Ball bearing
Technical features	<ul style="list-style-type: none"> - Output 10 VDC, max. 10 mA - Output 20 VDC, max. 50 mA - Output for slave 0-10 V - Input for sensor 0-10 V or 4-20 mA - Alarm relay - Integrated PID controller - Motor current limit - PFC, passive - RS485 ebmBUS - Soft start - Control input 0-10 VDC / PWM - Control interface with SELV potential safely disconnected from the mains - Over-temperature protected electronics / motor - Line undervoltage / phase failure detection
Touch current acc. IEC 60990 (measuring network Fig. 4, TN system)	<= 3.5 mA
Electrical connection	Terminal box
Motor protection	Thermal overload protector (TOP) wired internally
Protection class	I (if protective earth is connected by customer at the connection point of the housing)
Product conforming to standard	EN 61800-5-1; CE



Product drawing

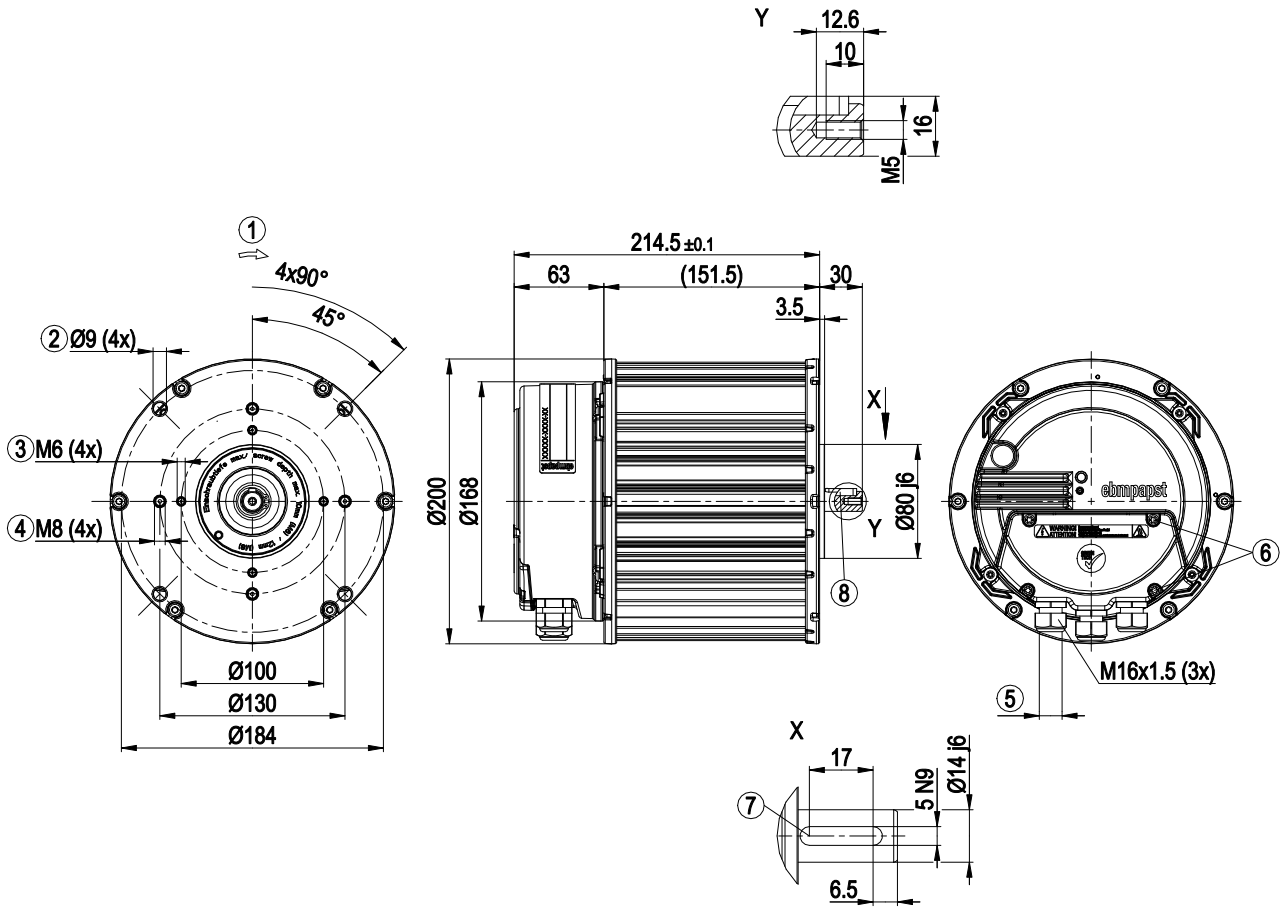

1	Direction of rotation clockwise, viewed towards shaft
2	Through-hole for screw M8
3	Thread reach max. 10 mm
4	Thread reach max. 12 mm
5	Cable diameter min. 4 mm, max. 10 mm, tightening torque 2.5±0.4 Nm
6	Tightening torque 3.5±0.5 Nm
7	Groove depth 3 mm
8	Key DIN 6885 – A – 5 x 5 x 22



Connection screen

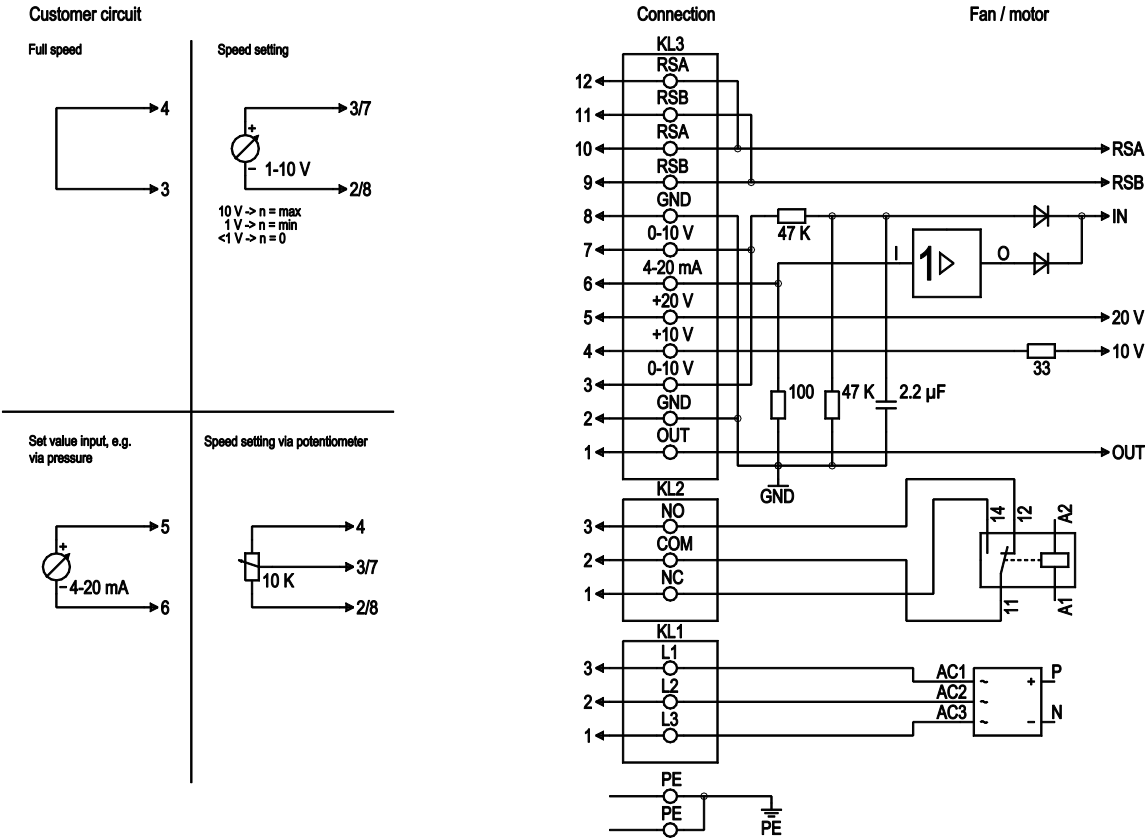

No.	Conn.	Designation	Function / assignment
PE		PE	Protective earth connection
KL1	1, 2, 3	L1, L2, L3	Supply voltage, 50/60 Hz
KL2	1	NC	Floating status message contact, normally closed connection; break for failure
KL2	2	COM	Floating status message contact, changeover contact, common connection (2 A, max. 250 VAC, min. 10 mA, AC1)
KL2	3	NO	Floating status message contact, normally open connection; make for failure
KL3	1	OUT	Analog output, 0-10 VDC, max. 3 mA, SELV, output of the current level control coefficient: 1 V equates to 10% level control coefficient. 10 V equate to 100% level control coefficient.
KL3	2, 8	GND	Reference mass for control interface, SELV
KL3	3, 7	0-10 V	Use control / actual value input 0-10 VDC, impedance 100 kΩ only as alternative to 4-20 mA input, SELV
KL3	4	+10 V	Voltage output 10 VDC (+/-3%), max. 10 mA, supply voltage for external devices (e.g. potentiometers), SELV
KL3	5	+20 V	Voltage output 20 VDC (+25%/-10%), max. 50 mA, supply voltage for external devices (e.g. sensors), SELV
KL3	6	4-20 mA	Use control / actual value input 4-20 mA, impedance 100 Ω, only as alternative to 0-10 V input, SELV
KL3	9, 11	RSB	RS485 interface for ebmBus, RSB, SELV
KL3	10, 12	RSA	RS485 interface for ebmBus, RSA, SELV



Charts: Speed (rpm)

