

M3G084-FA15-B5 ebmpapst Datasheet
 sales@fansco.com
 www.fansco.com

Nominal data

Type	M3G084-FA15-B5	
Motor	M3G084-FA	
Phase		1~
Nominal voltage	VDC	230
Frequency	Hz	50/60
Method of obtaining data		ml
Speed (rpm)	min ⁻¹	4000
Power consumption	W	680
Power output	W	570
Current draw	A	3.0
Rated torque	Ncm	135
Min. ambient temperature	°C	-40
Max. ambient temperature	°C	50

ml = Max. load · me = Max. efficiency · fa = Free air · cs = Customer specification · ce = Customer equipment
 Subject to change



Technical description

Weight	4.9 kg
Motor size	84
Rotor surface	Painted black
Electronics housing material	Die-cast aluminum
Direction of rotation	Counterclockwise, viewed toward rotor
Degree of protection	IP54
Insulation class	"B"
Moisture (F) / Environmental (H) protection class	H1
Max. permitted ambient temp. for motor (transport/storage)	+80 °C
Min. permitted ambient temp. for motor (transport/storage)	-40 °C
Installation position	Shaft horizontal or rotor on top
Condensation drainage holes	None
Mode	S1
Motor bearing	Ball bearing
Technical features	<ul style="list-style-type: none"> - Output 10 VDC, max. 10 mA - Output 20 VDC, max. 50 mA - Output for slave 0-10 V - Input for sensor 0-10 V or 4-20 mA - Alarm relay - Motor current limitation - Emergency operation, standstill on cable break - PFC, active - RS-485 MODBUS-RTU, 38,400 baud, no parity - Soft start - Control input 0-10 VDC / PWM - Control interface with SELV potential safely disconnected from supply - Thermal overload protection for electronics/motor - Line undervoltage / phase failure detection
EMC immunity to interference	According to EN 61000-6-2 (industrial environment)
EMC circuit feedback	According to EN 61000-3-2/3
EMC interference emission	According to EN 61000-6-3 (household environment)
Touch current according to IEC 60990 (measuring circuit Fig. 4, TN system)	<= 3.5 mA
Electrical hookup	Connector with cable
Motor protection	Thermal overload protector (TOP) internally connected
With cable	Variable
Protection class	I (with customer connection of protective earth)
Conformity with standards	EN 61800-5-1

Product drawing

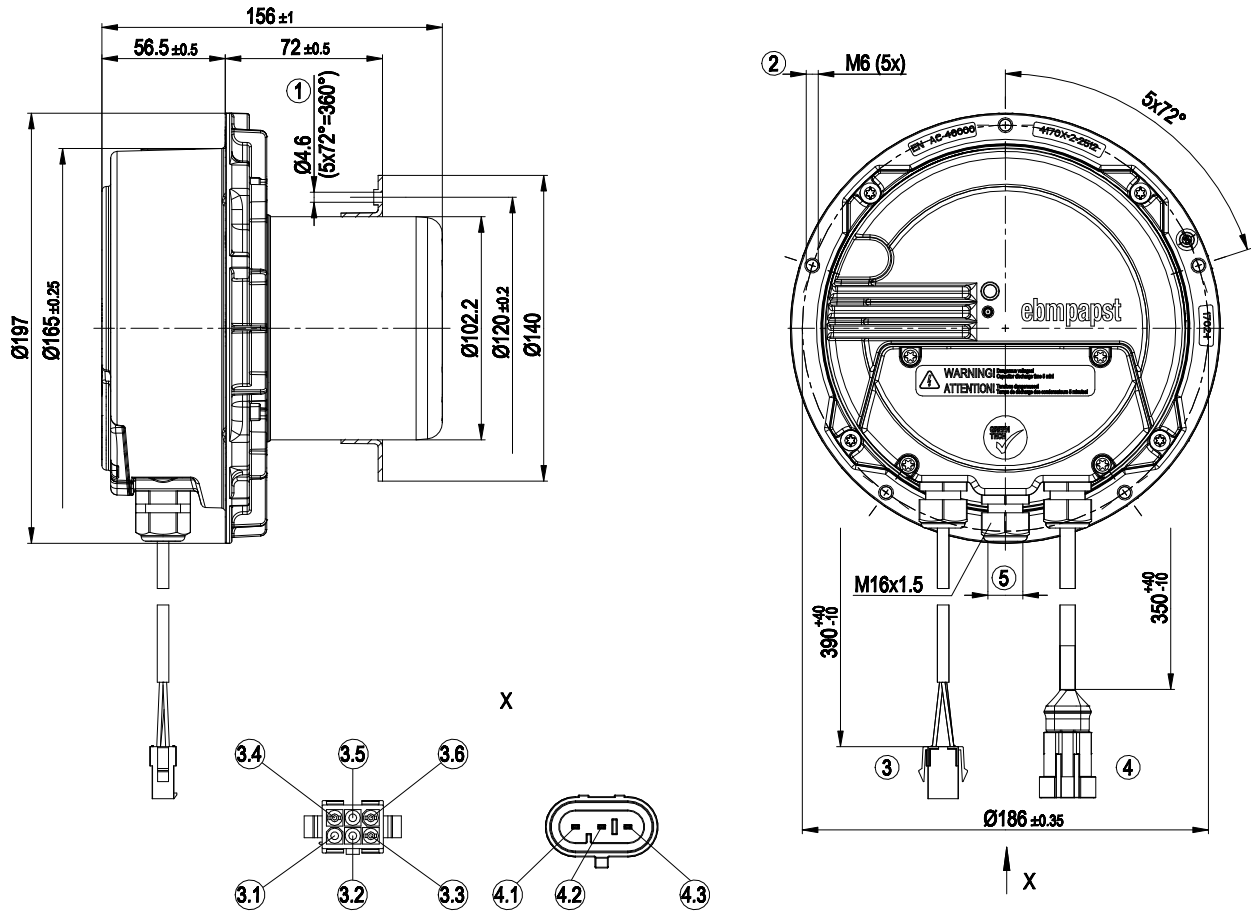

1	Extruded hole according to DIN 7952 for screw with self-tapping thread according to DIN 7500
2	Max. clearance for screw 10 mm
3	Cable PVC AWG22 with crimped connector housing AMP part no. 794940-1 and 3x plug pin AMP part no. 170360-3 with seal 794758-1 and 3x dummy plug 794995-1
3.1	Dummy plug
3.2	Dummy plug
3.3	RSB (red)
3.4	RSA (yellow)
3.5	Dummy plug
3.6	GND (blue)
4	Cable PVC AWG18 with crimped connector housing AMP part no. 282105-1 and 3x flat plug AMP part no. 282109-1 with seal 281934-2
4.1	L (black)
4.2	N (blue)
4.3	PE (green/yellow)
5	Cable diameter min. 4 mm, max. 10 mm, tightening torque 2.5 ± 0.4 Nm



Connection diagram

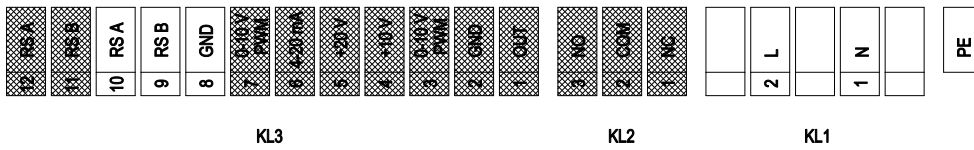

shaded gray => not brought out via leads

No.	Conn.	Designation	Color	Function/assignment
1	-	PE	green/yellow	Protective earth terminal
1	KL1	N	blue	Power supply, see nameplate for voltage range, 50/60 Hz
1	KL1	L	black	Power supply, see nameplate for voltage range, 50/60 Hz
2	KL2	NC	black	Floating status contact, break for failure
2	KL2	COM	white	Floating status contact, changeover contact, common connection (2 A, max. 250 VAC, min. 10 mA, AC1)
2	KL2	NO	yellow	Floating status contact, make for failure
-	KL3	OUT		Analog output, 0-10 VDC, max. 3 mA, SELV Output of current motor modulation level: 1 V corresponds to 10% modulation level. 10 V corresponds to 100% modulation level.
2	KL3	GND	blue	Reference ground for control interface, SELV
-	KL3	0-10 V PWM		Use control / current sensor value input 0-10 VDC, impedance 100 kΩ only as alternative to 4-20 mA input, SELV
-	KL3	+10 V		Voltage output 10 VDC (±3%), max. 10 mA, power supply for external devices (e.g. potentiometer), SELV
-	KL3	+20 V		Voltage output 20 VDC (+25%/-10%), max. 50 mA, power supply for external devices (e.g. sensors), SELV
-	KL3	4-20 mA		Use control / current sensor value input 4-20 mA, impedance 100 Ω only as alternative to 0-10 V input, SELV
2	KL3	0-10 V PWM	red	Use control / current sensor value input 0-10 VDC, impedance 100 kΩ only as alternative to 4-20 mA input, SELV
-	KL3	GND		Reference ground for control interface, SELV
-	KL3	RSB		RS485 interface for MODBUS, RSB
-	KL3	RSA		RS485 interface for MODBUS, RSA
-	KL3	RSB		RS485 interface for MODBUS, RSB
-	KL3	RSA		RS485 interface for MODBUS, RSA

Curves: Speed (rpm)

