

M3G084-DF04-I3 ebmpapst Datasheet

sales@fansco.com

www.fansco.com

Limited partnership · Headquarters Muldingen  
 County court Stuttgart · HRA 590344

General partner Elektrobau Muldingen GmbH · Headquarters Muldingen  
 County court Stuttgart · HRB 590142

## Nominal data

Type	M3G084-DF04-I3	
Motor	M3G084-DF	
Phase		1~
Nominal voltage	V	230
Nominal voltage range	V	200 .. 277
Type of data definition		ml/cu
State		prelim.
Speed (rpm)	min <sup>-1</sup>	2300
Power input	W	750
Power output	W	600
Current draw	A	3.3
Rated torque	Ncm	250
Min. ambient temperature	°C	-25
Max. ambient temperature	°C	60

ml = Max. load · me = Max. efficiency · fa = Running at free air · cs = Customer specs · cu = Customer unit  
 Subject to alterations



## Technical features

<b>Mass</b>	4.1 kg
<b>Size</b>	84 mm
<b>Surface of rotor</b>	Coated in black
<b>Material of electronics housing</b>	Die-cast aluminium
<b>Direction of rotation</b>	Clockwise, seen on rotor
<b>Type of protection</b>	IP 20
<b>Insulation class</b>	"F"
<b>Humidity (F)/environmental protection class (H)</b>	H0 - dry environment
<b>Note ambient temperature</b>	Occasional start-up between -40°C and -25°C is permissible. For continuous operation at ambient temperatures below -25°C (e.g. refrigeration applications) we recommend our fan version with special low-temperature bearings.
<b>Max. permissible ambient motor temp. (transp./ storage)</b>	+ 80 °C
<b>Min. permissible ambient motor temp. (transp./storage)</b>	- 40 °C
<b>Mounting position</b>	Any
<b>Cooling bore / aperture</b>	Rotor-side
<b>Operation mode</b>	S1
<b>Motor bearing</b>	Ball bearing
<b>Technical features</b>	<ul style="list-style-type: none"> <li>- Output 10 VDC, max. 10 mA</li> <li>- Operation and alarm display</li> <li>- Alarm relay</li> <li>- Integrated PID controller</li> <li>- Output limit</li> <li>- Motor current limit</li> <li>- PFC, active</li> <li>- RS485 MODBUS RTU</li> <li>- Soft start</li> <li>- Control input 0-10 VDC / PWM</li> <li>- Control interface with SELV potential safely disconnected from the mains</li> <li>- Over-temperature protected electronics / motor</li> <li>- Line undervoltage / phase failure detection</li> </ul>
<b>EMC interference immunity</b>	Acc. to EN 61000-6-2 (industrial environment)
<b>EMC harmonics</b>	Acc. to EN 61000-3-2/3
<b>EMC interference emission</b>	Acc. to EN 61000-6-3 (household environment)
<b>Touch current acc. IEC 60990 (measuring network Fig. 4, TN system)</b>	<= 3.5 mA
<b>Motor protection</b>	Thermal overload protector (TOP) wired internally
<b>Cable exit</b>	Variable
<b>Protection class</b>	I (if protective earth is connected by customer)
<b>Product conforming to standard</b>	EN 61800-5-1; EN 60335-1; CE
<b>Approval</b>	UL 1004-7 + 60730; C22.2 Nr.77 + CAN/CSA-E60730-1; EAC



Product drawing

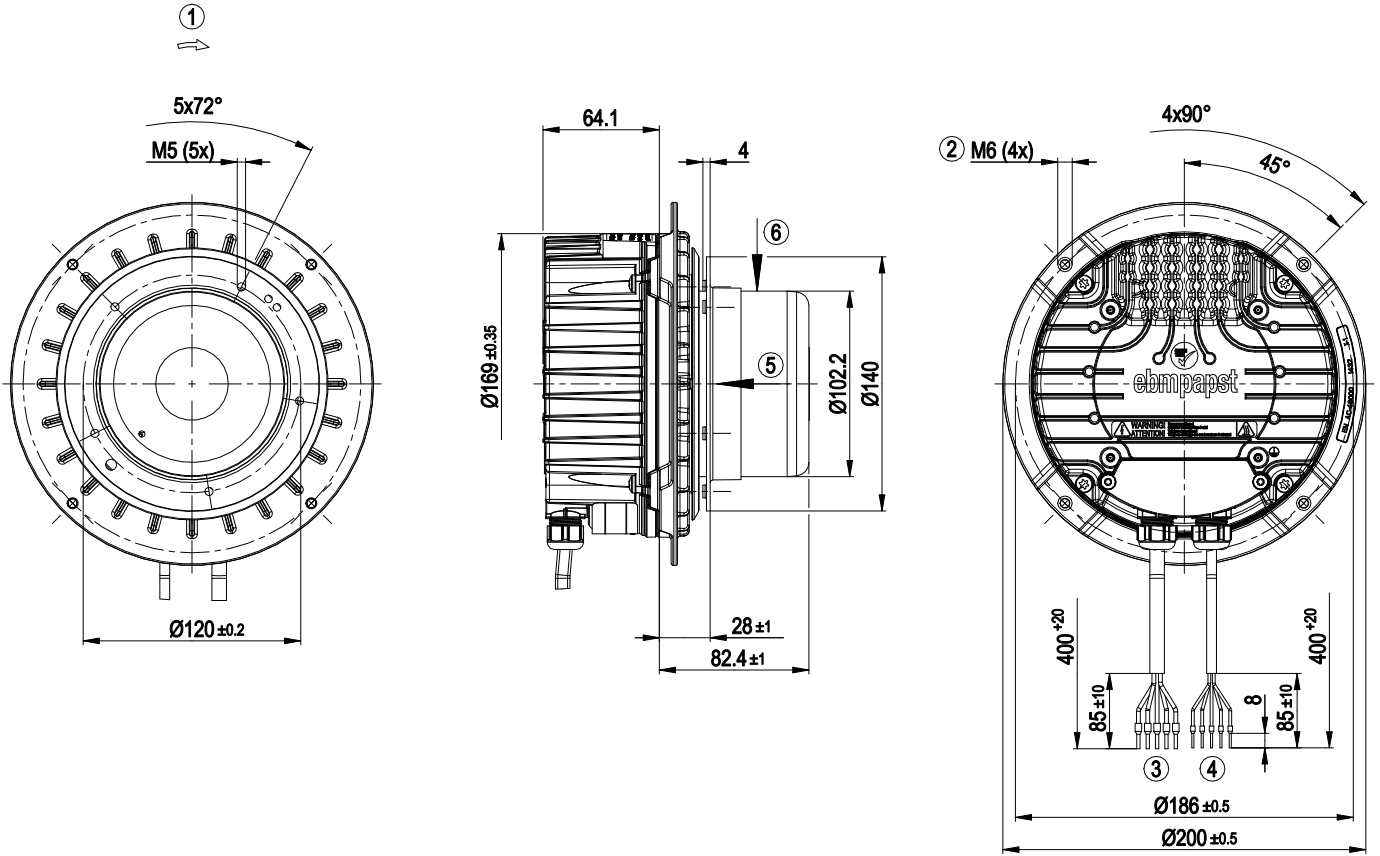

1	Direction of rotation clockwise, viewed towards rotor
2	Thread reach max. 10 mm
3	Connection line PVC AWG18, 5x crimped core-end sleeves
4	Connection line PVC AWG22, 5x crimped core-end sleeves
5	Max. permissible axial load: 40 N (referenced to mounting position at rotor flange)
6	Max. permissible radial load: 40 N (referenced to mounting position at rotor flange)
-	Max. permissible balance quality grade: G 6.3 as per DIN ISO 1940-1



## Connection screen

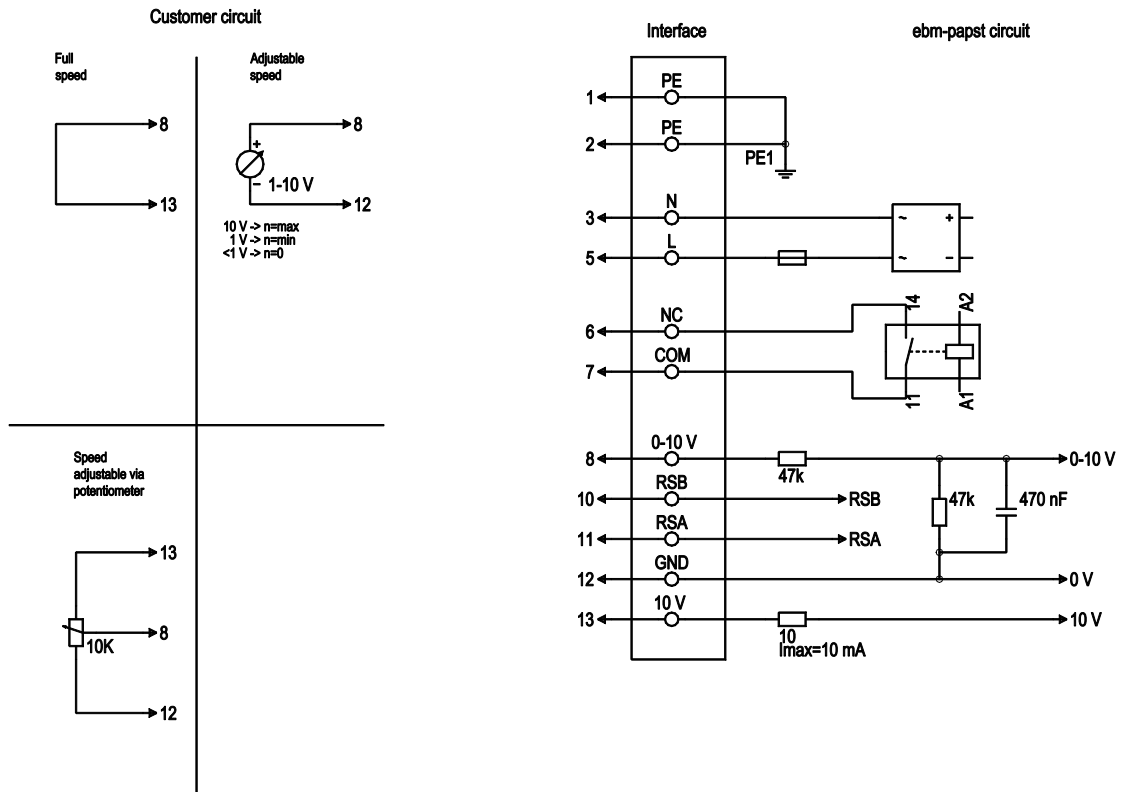

No.	Conn.	Designation	Colour	Function / assignment
1	1, 2	PE	green/yellow	Protective earth
1	3	N	blue	Supply voltage, neutral conductor, 50/60 Hz
1	5	L	black	Supply voltage, phase, 50/60 Hz
1	6	NC	white 1	Status relay, floating status contact; break for failure, contact rating 250 VAC / 2A (AC1) min. 10 mA, basic insulation on mains side and reinforced insulation on control interface side
1	7	COM	white 2	Status relay, floating status contact; common connection, contact rating 250 VAC / 2A (AC1) min. 10 mA, basic insulation on mains side and reinforced insulation on control interface side
2	8	0-10V	yellow	Analogue input 1 (set value); 0-10 V; Ri=100kΩ; parametrisable curve
2	10	RSB	brown	RS485 interface for Modbus, RSB
2	11	RSA	white	RS485 interface for Modbus, RSA
2	12	GND	blue	Reference ground for control interface, SELV
2	13	+10V	red	Fixed voltage output 10 VDC; +10 V +/-3%; max. 10 mA; short-circuit-proof; power supply for external devices (e.g. potentiometer)



Charts: Speed (rpm)

