

M3G074-DF03-11 ebmpapst Datasheet  
 sales@fansco.com  
 www.fansco.com

Limited partnership · Headquarters Muldingen  
 County court Stuttgart · HRA 590344

General partner Elektrobau Muldingen GmbH · Headquarters Muldingen  
 County court Stuttgart · HRB 590142

## Nominal data

<b>Type</b>	<b>M3G074-DF03-11</b>	
<b>Motor</b>	<b>M3G074-DF</b>	
Phase		1~
Nominal voltage	VAC	230
Nominal voltage range	VAC	200 .. 240
Frequency	Hz	50/60
Type of data definition		ml
State		prelim.
Speed (rpm)	min <sup>-1</sup>	1400
Power input	W	170
Power output	W	130
Current draw	A	1.6
Rated torque	Ncm	91
Min. ambient temperature	°C	-25
Max. ambient temperature	°C	40

ml = Max. load · me = Max. efficiency · fa = Running at free air · cs = Customer specs · cu = Customer unit  
 Subject to alterations



## Technical features

Mass	2.1 kg
Motor size	74
Surface of rotor	Galvanised
Direction of rotation	Counter-clockwise, seen on rotor
Type of protection	IP54
Insulation class	"B"
Humidity (F) / environmental protection class (H)	H1+
Max. permissible ambient motor temp. (transp./ storage)	+ 80 °C
Min. permissible ambient motor temp. (transp./storage)	- 40 °C
Mounting position	Any
Condensation drainage holes	None, open rotor
Cooling bore / aperture	Rotor-side
Operation mode	S1
Motor bearing	Ball bearing
Technical features	<ul style="list-style-type: none"> <li>- Output 10 VDC, max. 10 mA</li> <li>- Tach output</li> <li>- Output limit</li> <li>- Motor current limit</li> <li>- Soft start</li> <li>- Control input 10-0 VDC / PWM</li> <li>- Control interface with SELV potential safely disconnected from the mains</li> <li>- Overvoltage detection</li> <li>- Over-temperature protected electronics / motor</li> <li>- Line undervoltage detection</li> </ul>
Touch current acc. IEC 60990 (measuring network Fig. 4, TN system)	<= 3.5 mA
Motor protection	Electronic motor protection
Cable exit	Variable
Protection class	I (if protective earth is connected by customer)
Product conforming to standard	CE



Product drawing

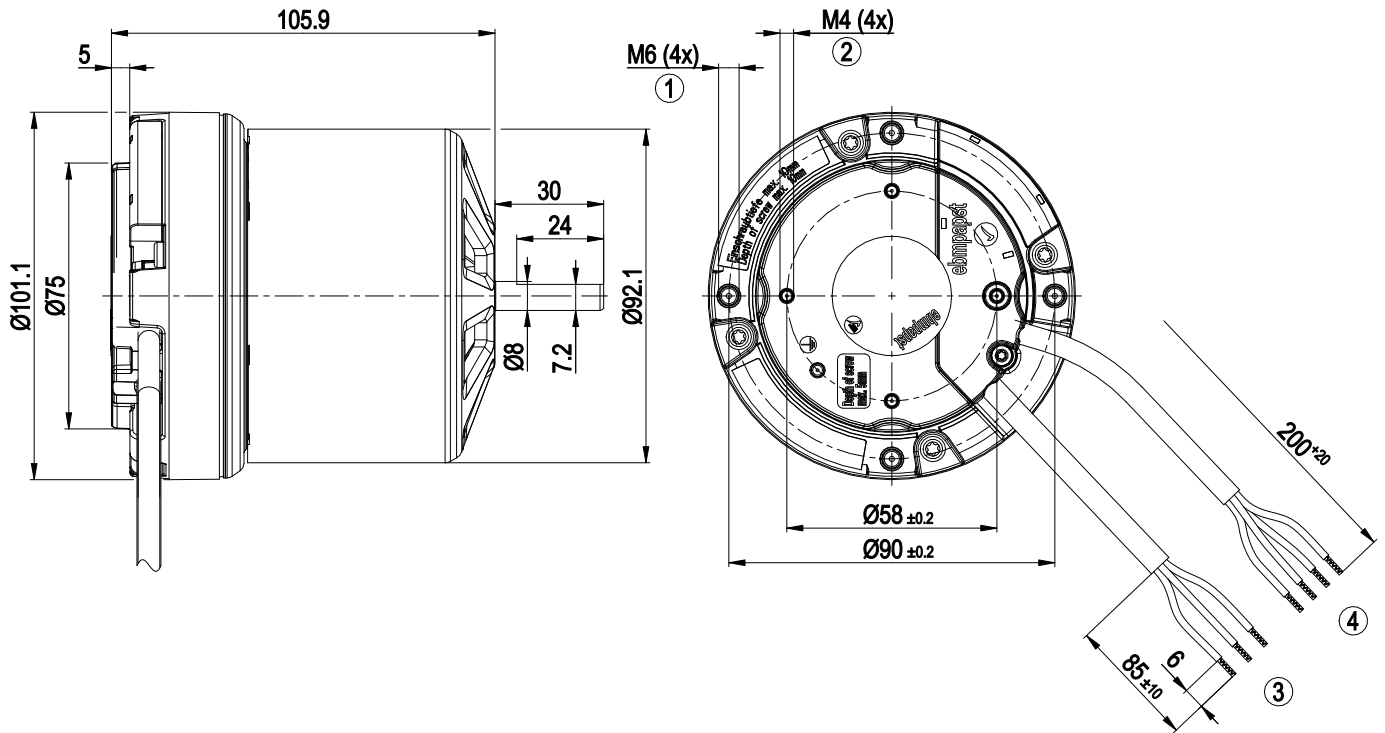

1	Thread reach max. 10 mm
2	Thread reach max. 5 mm
3	Connection line PVC 3G AWG20, 3x lead tips crimped
4	Connection line PVC 4x AWG22, 4x lead tips crimped



## Connection screen

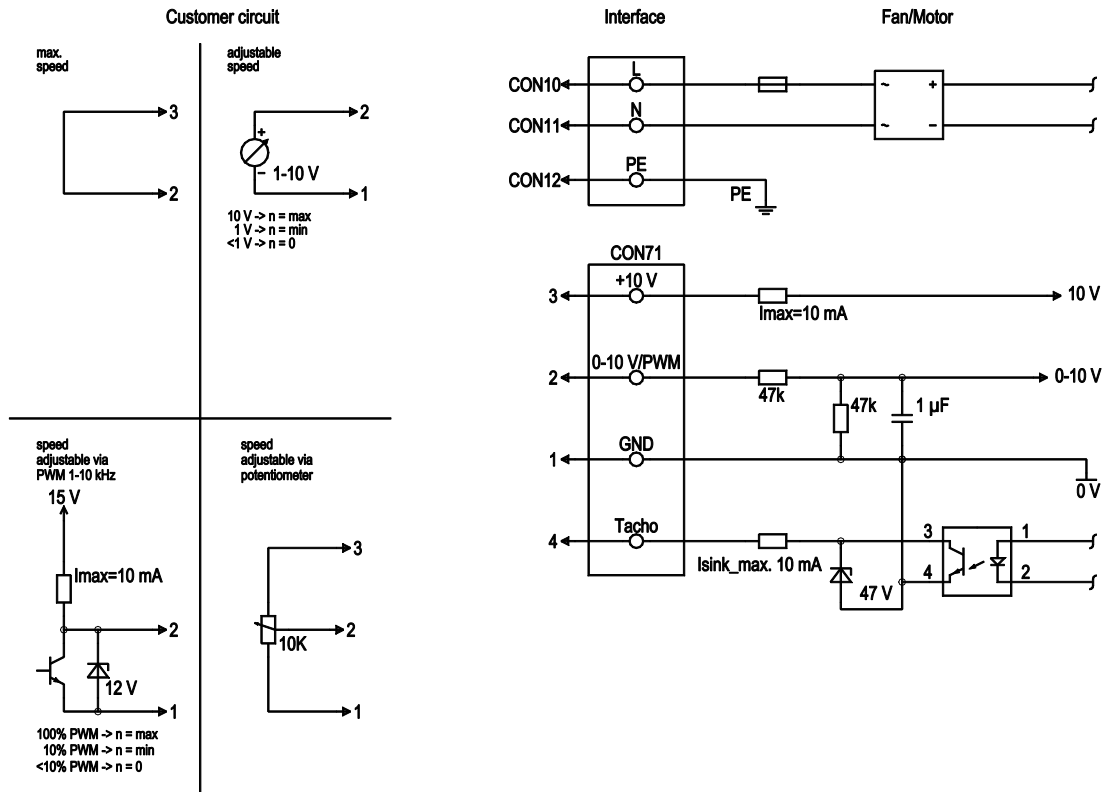

No.	Conn.	Designation	Colour	Function / assignment
	CON10	L	black	Power supply, phase, see type plate for voltage range
	CON11	N	blue	Power supply, neutral conductor, see type plate for voltage range
	CON12	PE	green/yellow	Protective earth
	2	0- 10V PWM	yellow	Control input 0-10 V or PWM, impedance 100 kΩ, SELV, parametrisable curve
	4	Tach	white	Tach output: Open collector, 1 pulse/revolution, SELV
	3	+10 V	red	Voltage output, power supply for external devices (e.g. potentiometers), SELV
	1	GND	blue	Signal ground for control interface, SELV



## Charts: Speed (rpm)

