

M2E068-EC07-18 ebmpapst Datasheet
 sales@fansco.com
 www.fansco.com

Nominal data

Type	M2E068-EC07-18	
Motor	M2E068-EC	
Phase		1~
Nominal voltage	VAC	208
Frequency	Hz	60
Method of obtaining data		me
Valid for approval/standard		CE/UL
Speed (rpm)	min ⁻¹	2800
Power consumption	W	220
Power output	W	110
Current draw	A	1.10
Rated torque	Ncm	37
Mean starting torque	Ncm	21
Capacitor	μF	6
Capacitor voltage	VDB	400
Capacitor standard		S2 (CE)
Max. ambient temperature	°C	-
Starting current	A	1.55

ml = Max. load · me = Max. efficiency · fa = Free air · cs = Customer specification · ce = Customer equipment
 Subject to change



Technical description

Weight	2.2 kg
Fan size	68 mm
Rotor surface	Rotor open, painted black
Direction of rotation	Clockwise, viewed toward rotor
Degree of protection	IP10
Insulation class	"F"
Moisture (F) / Environmental (H) protection class	H0 - dry environment
Max. permitted ambient temp. for motor (transport/storage)	+ 80 °C
Min. permitted ambient temp. for motor (transport/storage)	- 40 °C
Installation position	Any
Condensation drainage holes	None, open rotor
Mode	S1
Motor bearing	Ball bearing
Touch current according to IEC 60990 (measuring circuit Fig. 4, TN system)	< 0.75 mA
Motor protection	Thermal overload protector (TOP) internally connected
Protection class	I (with customer connection of protective earth)
Conformity with standards	EN 60335-1; CE

Product drawing

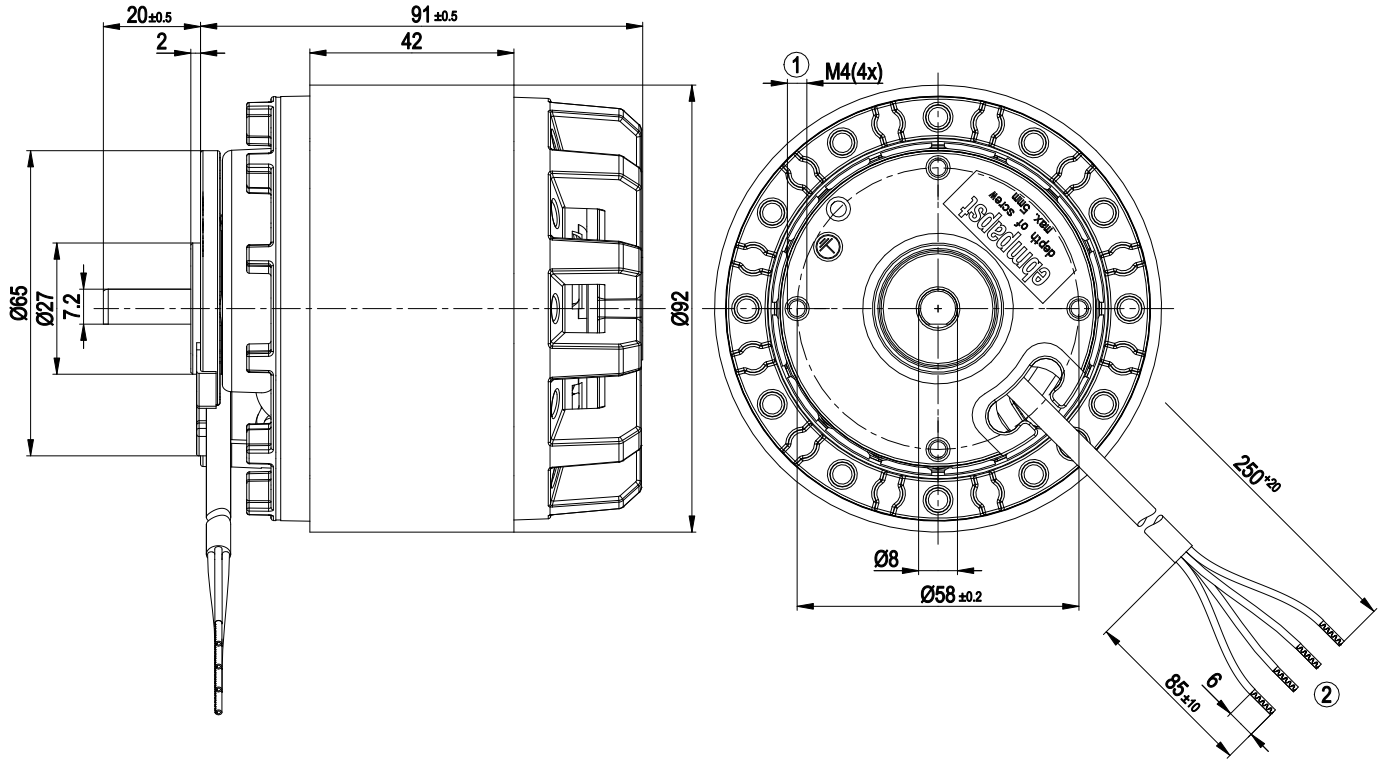

- 1 Max. clearance for screw 5 mm
- 2 Cable silicone 4G 0.5 mm², 4x crimped splices

Connection diagram

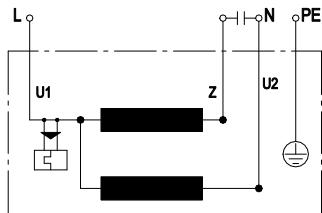

U1	blue	Z	brown	U2	black
PE	green/yellow				



Curves: Speed (rpm)

