

# EC centrifugal module

backward curved, single inlet  
 in cube design

K3G800-AS07-08 ebmpapst Datasheet  
 sales@fansco.com  
 www.fansco.com

Limited partnership · Headquarters Muldingen  
 County court Stuttgart · HRA 590344

General partner Elektrobau Muldingen GmbH · Headquarters Muldingen  
 County court Stuttgart · HRB 590142

## Nominal data

<b>Type</b>	<b>K3G800-AS07-08</b>	
<b>Motor</b>	<b>M3G200-QA</b>	
Phase		3~
Nominal voltage	VAC	400
Nominal voltage range	VAC	380 .. 480
Frequency	Hz	50/60
Type of data definition		ml
Speed (rpm)	min <sup>-1</sup>	1370
Power input	W	11600
Current draw	A	17.8
Min. ambient temperature	°C	-25
Max. ambient temperature	°C	40

ml = Max. load · me = Max. efficiency · fa = Running at free air · cs = Customer specs · cu = Customer unit  
 Subject to alterations

## Data in accordance with ecodesign regulation EU 327/2011 (EN 17166)

		Actual	Request 2015			
01 Overall efficiency $\eta_{es}$	%	67.2	62.1	09 Power input $P_{ed}$	kW	11.65
02 Measurement category		A		09 Air flow $q_v$	m <sup>3</sup> /h	23015
03 Efficiency category		Static		09 Pressure increase $p_{fs}$	Pa	1174
04 Efficiency grade N		67.1	62	10 Speed (rpm) $n$	min <sup>-1</sup>	1365
05 Variable speed drive		Yes		11 Specific ratio*		1.01

Data definition with optimum efficiency.  
 The ErP data is determined using a motor-impeller combination in a standardised measurement configuration.

\* Specific ratio =  $1 + p_{fs} / 100\,000\text{ Pa}$

LU-153201



K3G800-AS07-08

Al-Ko Therm GmbH

# EC centrifugal module

backward curved, single inlet

in cube design

## Technical features

Mass	209 kg
Size	800 mm
Motor size	200
Surface of rotor	Coated in black
Material of electronics housing	Die-cast aluminium, coated in black
Material of impeller	Aluminium sheet
Material of inlet nozzle	Sheet steel, galvanised and plastic-coated in light grey (RAL 7035)
Material of support structure	Sheet steel, galvanised and plastic-coated in light grey (RAL 7035)
Number of blades	7
Direction of rotation	Clockwise, seen on rotor
Type of protection	IP55
Insulation class	"F"
Humidity (F) / environmental protection class (H)	H2
Note ambient temperature	Occasional start-up between -40°C and -25°C is permissible. For continuous operation at ambient temperatures below -25°C (e.g. refrigeration applications) we recommend our fan version with special low-temperature bearings.
Max. permissible ambient motor temp. (transp./ storage)	+80 °C
Min. permissible ambient motor temp. (transp./storage)	-40 °C
Mounting position	Shaft horizontal (base mounting only)
Condensation drainage holes	Rotor-side
Operation mode	S1
Motor bearing	Ball bearing
Technical features	<ul style="list-style-type: none"><li>- Output 10 VDC, max. 10 mA</li><li>- Output 20 VDC, max. 50 mA</li><li>- Output for slave 0-10 V</li><li>- Operation and alarm display</li><li>- Input for sensor 0-10 V or 4-20 mA</li><li>- External 24 V input (programming)</li><li>- Alarm relay</li><li>- Integrated PID controller</li><li>- Output limit</li><li>- Motor current limit</li><li>- PFC, passive</li><li>- RS485 MODBUS RTU</li><li>- Soft start</li><li>- Maximum EEPROM write cycles 100,000</li><li>- Control input 0-10 VDC / PWM</li><li>- Control interface with SELV potential safely disconnected from the mains</li><li>- Temperature derating</li><li>- Over-temperature protected electronics / motor</li><li>- Line undervoltage / phase failure detection</li></ul>
Touch current acc. IEC 60990 (measuring network Fig. 4, TN system)	<= 3.5 mA
Electrical connection	Terminal box
Motor protection	Reverse polarity and locked-rotor protection
Protection class	I (if protective earth is connected by customer)



**K3G800-AS07-08**  
AI-Ko Therm GmbH

# EC centrifugal module

backward curved, single inlet  
in cube design

<b>Product conforming to standard</b>	EN 61800-5-1; CE
<b>Approval</b>	CSA C22.2 no. 77 + CAN/CSA-E60730-1; EAC; UL 1004-7 + 60730-1
<b>Remark</b>	Max. vibration velocity 2.8 mm/s



# EC centrifugal module

backward curved, single inlet  
 in cube design

## Product drawing

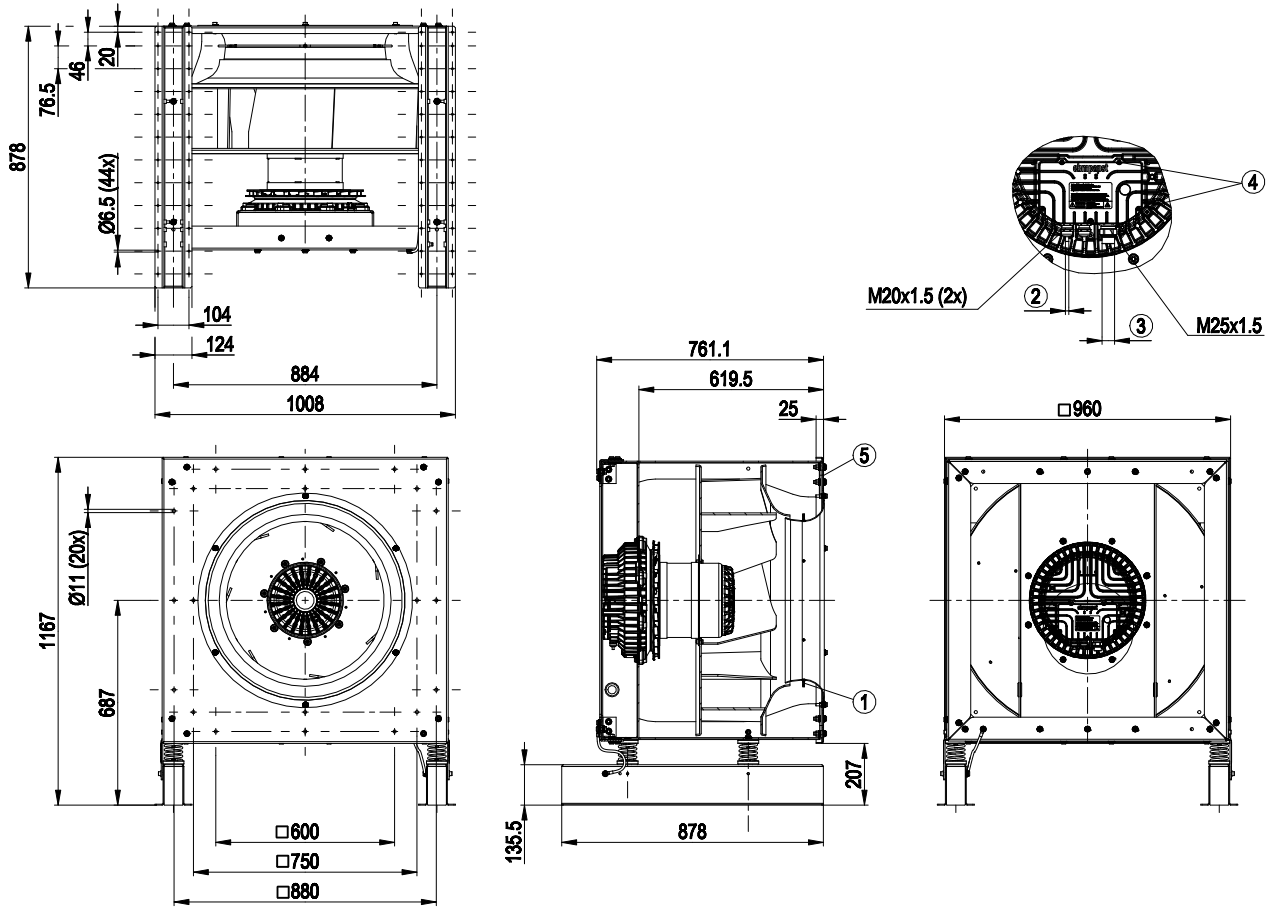

1	Inlet nozzle with ring line (k-factor: 696)
2	Cable diameter min. 4 mm, max. 10 mm, tightening torque $6 \pm 0.9$ Nm
3	Cable diameter min. 16 mm, max. 20.5 mm, tightening torque $6 \pm 0.9$ Nm
4	Tightening torque $3.5 \pm 0.5$ Nm
5	The device is tilted forward by $0.5^\circ - 1.5^\circ$



# EC centrifugal module

backward curved, single inlet  
 in cube design

## Connection screen

8	Din 2
9	Din 3
10	GND
11	Ain 2 U
12	+ 20 V
13	Ain 2 I
14	Aout
1	RSA
2	RSB
3	GND
4	Ain 1 U
5	+ 10 V
6	Ain 1 I
7	Din 1

KL 3

1	NO
2	COM
3	NC

KL 2

1	L1
2	L2
3	L3
	PE

KL 1 PE

No.	Conn.	Designation	Function / assignment
KL 1	1	L1	Mains supply connection, supply voltage 3-phase 380-480 VAC; 50/60 Hz
KL 1	2	L2	Mains supply connection, supply voltage 3-phase 380-480 VAC; 50/60 Hz
KL 1	3	L3	Mains supply connection, supply voltage 3-phase 380-480 VAC; 50/60 Hz
PE		PE	Earth connection, PE connection
KL 2	1	NO	Status relay, floating status contact; normally open; make for failure
KL2	2	COM	Status relay; floating status contact; changeover contact; common connection; contact rating 250 VAC / max. 2 A (AC1) / min. 10 mA
KL2	3	NC	Status relay, floating status contact; break for failure
KL 3	1	RSA	Bus connection RS485; RSA; MODBUS RTU
KL 3	2	RSB	Bus connection RS485; RSB; MODBUS RTU
KL 3	3 / 10	GND	Reference ground for control interface
KL 3	4	Ain1 U	Analogue input 1 (set value); 0-10 V; Ri= 100 kΩ; parametrisable curves; only usable as alternative to input Ain1 I
KL 3	5	+ 10 V	Fixed voltage output 10 VDC; + 10 V +/-3%; max. 10 mA; short circuit proof; power supply for ext. devices (e.g. potentiometer)
KL 3	6	Ain1 I	Analogue input 1 (set value); 4-20 mA; Ri= 100 Ω; parametrisable curves; only usable as alternative to input Ain1 U
KL 3	7	Din1	Digital input 1: enabling of electronics; enabling: open pin or applied voltage 5 to 50 VDC; disabling: bridge to GND or applied voltage < 1 VDC; reset function: triggers software reset after a level change to <1 V
KL 3	8	Din2	Digital input 2: parameter set switch 1/2; according to EEPROM setting, the valid/used parameter set is selectable per BUS or per digital input DIN2. Parameter set 1: open pin or applied voltage 5 to 50 VDC; parameter set 2: bridge to GND or applied voltage < 1 VDC
KL 3	9	Din3	Digital input 3: Control characteristic of the integrated controller; according to EEPROM setting, the control characteristic of the integrated controller is normally/inversely selectable per BUS or per digital input; normal: open pin or applied voltage 5 to 50 VDC (control deviation = actual sensor value - set value) inverse: bridge to GND or applied voltage < 1 VDC (control deviation = set value - actual sensor value)
KL 3	11	Ain2 U	Analogue input 2; actual sensor value 0-10 V; Ri= 100 kΩ; parametrisable curve; only usable as alternative to input Ain2 I
KL 3	12	+ 20 V	Fixed voltage output 20 VDC; + 20V +/-25/-10%; max. 50 mA; short circuit proof; supply voltage for ext. devices (e.g. sensors)
KL 3	13	Ain2 I	Analogue input 2; actual sensor value 4-20 mA; Ri= 100 Ω; parametrisable curve; only usable as alternative to input Ain2 U
KL 3	14	Aout	Analogue output 0-10 V; max. 5 mA; output of the actual motor control factor (output voltage of electronics)/ of the actual motor speed. Parametrisable curve.



# EC centrifugal module

backward curved, single inlet  
in cube design

## Charts: Air flow 50 Hz

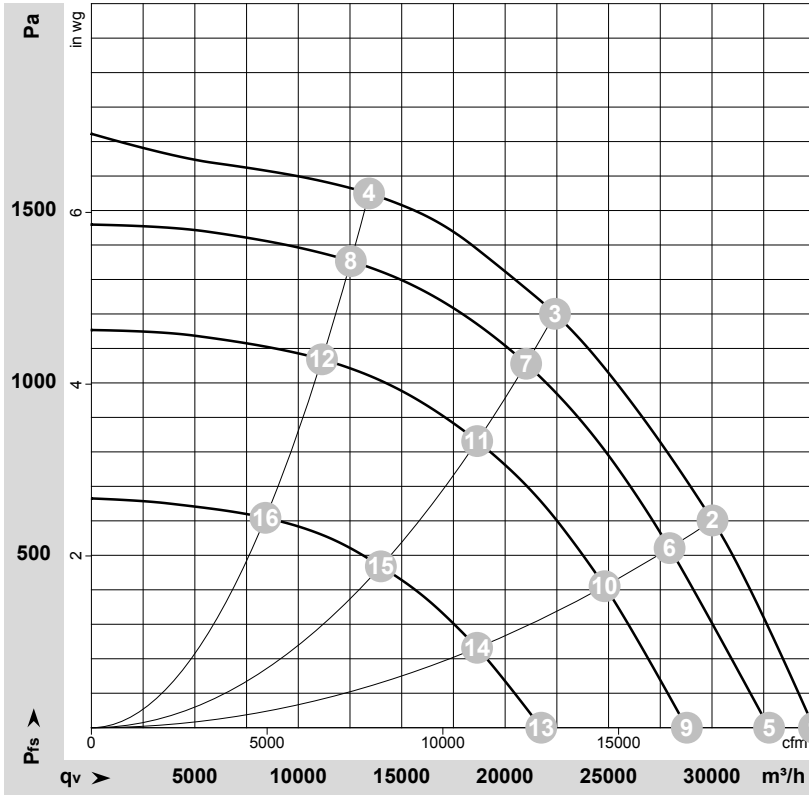

$\rho = 1.15 \text{ kg/m}^3 \pm 2 \%$

Measurement: LU-153201-1

Air performance measured as per ISO 5801 Installation category A. For detailed information on the measuring set-up, please contact ebmpapst. Suction-side noise levels:  $L_{wA}$  measured as per ISO 13347 /  $L_{pA}$  measured with 1m distance to fan axis. The values given are valid under the measuring conditions mentioned above and may vary according to the actual installation situation. With any deviation from the standard set-up, the specific values have to be checked and reviewed with the unit installed.

## Measured values

	U	f	n	$P_{ed}$	I	$L_{pA_{in}}$	$L_{wA_{in}}$	$L_{wA_{out}}$	$q_v$	$P_{fs}$	$q_v$	$P_{fs}$
	V	Hz	$\text{min}^{-1}$	W	A	dB(A)	dB(A)	dB(A)	$\text{m}^3/\text{h}$	Pa	cfm	in. wg
1	400	50	1370	7004	10.93	93	104	107	34930	0	20560	0.00
2	400	50	1370	10000	15.40	87	96	100	30025	600	17670	2.41
3	400	50	1370	11600	17.80	82	90	94	22410	1200	13190	4.82
4	400	50	1370	10821	16.62	86	93	96	13420	1550	7900	6.22
5	400	50	1280	5708	9.01	92	102	106	32760	0	19280	0.00
6	400	50	1280	8169	12.67	88	94	98	27950	521	16450	2.09
7	400	50	1280	9663	14.88	80	88	93	21015	1058	12370	4.25
8	400	50	1280	8811	13.63	83	90	94	12545	1354	7385	5.44
9	400	50	1140	4081	6.69	92	99	103	28785	0	16940	0.00
10	400	50	1140	5730	9.09	82	91	94	24810	410	14600	1.65
11	400	50	1140	6745	10.58	77	85	90	18650	834	10975	3.35
12	400	50	1140	6221	9.83	79	87	91	11145	1070	6560	4.30
13	400	50	860	1841	3.75	81	90	94	21745	0	12800	0.00
14	400	50	860	2568	4.74	74	82	87	18645	232	10975	0.93
15	400	50	860	2998	5.31	70	78	83	13995	469	8235	1.88
16	400	50	860	2766	5.00	71	78	83	8415	610	4950	2.45

U = Supply voltage · f = Frequency · n = Speed (rpm) ·  $P_{ed}$  = Power input · I = Current draw ·  $L_{pA_{in}}$  = Sound pressure level inlet side ·  $L_{wA_{in}}$  = Sound power level inlet side ·  $L_{wA_{out}}$  = Sound power level outlet side  
 $q_v$  = Air flow ·  $P_{fs}$  = Pressure increase

