

backward curved, single inlet

with support bracket

K3G630-RB32-75 ebmpapst Datasheet

sales@fansco.com

www.fansco.com

Limited partnership · Headquarters Mulfingen
County court Stuttgart · HRA 590344

General partner Elektrobau Mulfingen GmbH · Headquarters Mulfingen
County court Stuttgart · HRB 590142

Nominal data

Type	K3G630-RB32-75	
Motor	M3G150-IF	
Phase		3~
Nominal voltage	VAC	400
Nominal voltage range	VAC	380 .. 480
Frequency	Hz	50/60
Type of data definition		ml
Speed (rpm)	min ⁻¹	1300
Power input	W	2800
Current draw	A	4.2
Min. ambient temperature	°C	-25
Max. ambient temperature	°C	55

ml = Max. load · me = Max. efficiency · fa = Running at free air · cs = Customer specs · cu = Customer unit
Subject to alterations

Data in accordance with ecodesign regulation EU 327/2011

		Actual	Request 2015			
01 Overall efficiency η_{es}	%	65	56.2	09 Power input P_{ed}	kW	2.79
02 Measurement category		A		09 Air flow q_v	m ³ /h	11320
03 Efficiency category		Static		09 Pressure increase p_{fs}	Pa	549
04 Efficiency grade N		70.8	62	10 Speed (rpm) n	min ⁻¹	1305
05 Variable speed drive		Yes		11 Specific ratio*		1.01

Data definition with optimum efficiency.

The ErP data is determined using a motor-impeller combination in a standardised measurement configuration.

* Specific ratio = $1 + p_{fs} / 100\,000\text{ Pa}$

LU-164207



backward curved, single inlet
with support bracket

Technical features

Mass	52 kg
Size	630 mm
Surface of rotor	Coated in black
Material of electronics housing	Die-cast aluminium
Material of impeller	PP plastic
Material of mounting plate	Sheet steel, galvanised
Material of support bracket	Steel, coated in black
Material of inlet nozzle	Sheet steel, galvanised
Number of blades	6
Direction of rotation	Clockwise, seen on rotor
Type of protection	IP 55
Insulation class	"F"
Humidity (F)/environmental protection class (H)	H1
Max. permissible ambient motor temp. (transp./ storage)	+80 °C
Min. permissible ambient motor temp. (transp./storage)	-40 °C
Mounting position	Refer to product drawing
Condensate discharge holes	Rotor-side
Operation mode	S1
Motor bearing	Ball bearing
Technical features	<ul style="list-style-type: none"> - Output 10 VDC, max. 10 mA - Operation and alarm display - External 24 V input (programming) - External release input - Alarm relay - Integrated PID controller - Motor current limit - PFC, passive - RS485 MODBUS RTU - Soft start - Control input 0-10 VDC / PWM - Control interface with SELV potential safely disconnected from the mains - Over-temperature protected electronics / motor - Line undervoltage / phase failure detection
Touch current acc. IEC 60990 (measuring network Fig. 4, TN system)	<= 3.5 mA
Electrical leads	Via terminal box
Motor protection	Reverse polarity and locked-rotor protection
Protection class	I (if protective earth is connected by customer)
Product conforming to standard	EN 61800-5-1; CE
Approval	EAC



EC centrifugal module - RadiCal

backward curved, single inlet
with support bracket

Product drawing

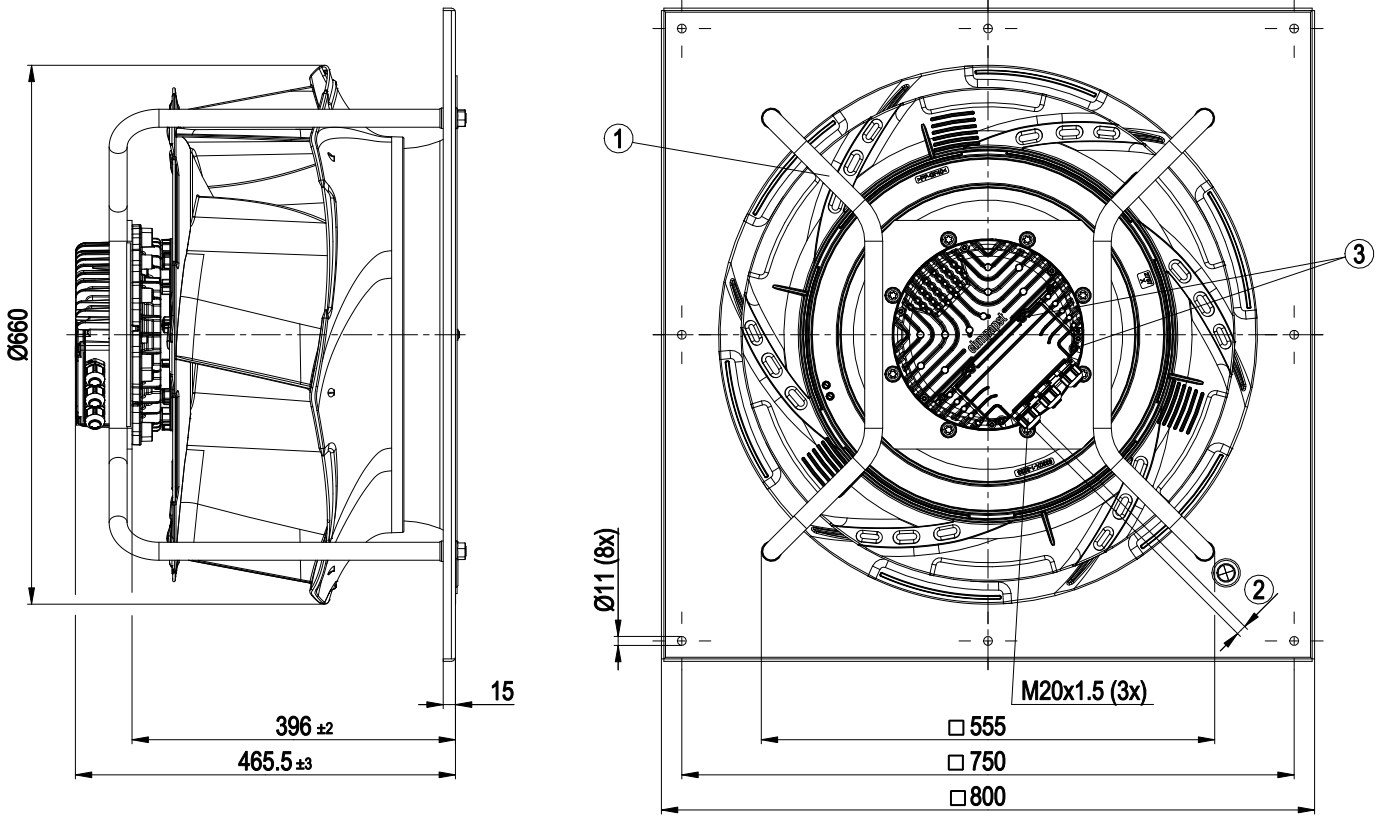

1	Installation position: Shaft horizontal (only install the support struts vertically as shown) or rotor at bottom; rotor at top on request
2	Cable diameter min. 4 mm, max. 10 mm, tightening torque 4 ± 0.6 Nm
3	Tightening torque 3.5 ± 0.5 Nm



EC centrifugal module - RadiCal

backward curved, single inlet
with support bracket

Connection screen

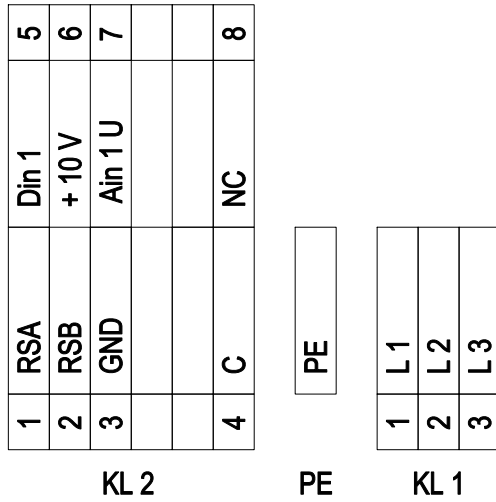

No.	Conn.	Designation	Function / assignment
KL 1	1	L1	Mains supply connection, supply voltage 3~380-480 VAC; 50/60 Hz
KL 1	2	L2	Mains supply connection, supply voltage 3~380-480 VAC; 50/60 Hz
KL 1	3	L3	Mains supply connection, supply voltage 3~380-480 VAC; 50/60 Hz
PE		PE	Earth connection, PE connection
KL 2	1	RSA	Bus connection RS-485, RSA, MODBUS RTU; SELV
KL 2	2	RSB	Bus connection RS-485, RSB, MODBUS RTU; SELV
KL 2	3	GND	Signal ground for control interface; SELV
KL2	4	C	Status relay; floating status contact; changeover contact; common connection; contact rating 250 VAC / 2 A (AC1)
KL 2	5	Din1	Digital input 1 enabling of electronics, enabling: open pin or applied voltage 5-50 VDC disabling: bridge to GND or applied voltage <1 VDC reset function: triggers software reset after a level change to <1 V; SELV
KL 2	6	+ 10 V	Fixed voltage output 10 VDC; +10 V -3 %, max. 10 mA, short-circuit-proof, power supply for external devices (e.g. potentiometer); SELV Alternative: +24 VDC input for parametrisation via MODBUS without mains power
KL 2	7	Ain1 U	Analogue input 1 (set value) 0-10 V, Ri=100 kΩ, parametrisable curve; SELV
KL2	8	NC	Status relay, floating status contact; break for failure



Charts: Air flow 50 Hz

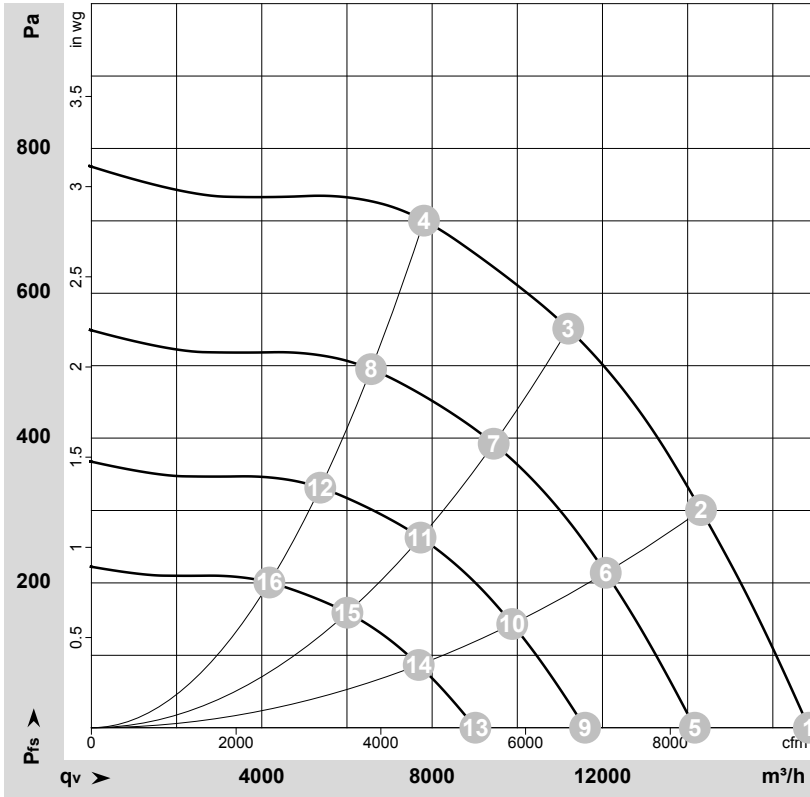

$\rho = 1.15 \text{ kg/m}^3 \pm 2 \%$

Measurement: LU-164207-1

Air performance measured as per ISO 5801 Installation category A. For detailed information on the measuring set-up, please contact ebmpapst. Suction-side noise levels: LwA measured as per ISO 13347 / LpA measured with 1m distance to fan axis. The values given are valid under the measuring conditions mentioned above and may vary according to the actual installation situation. With any deviation from the standard set-up, the specific values have to be checked and reviewed with the unit installed.

Measured values

	Conn.	U	f	n	P _{ed}	I	LpA _{in}	LwA _{in}	LwA _{out}	q _v	P _{fs}	q _v	P _{fs}
		V	Hz	min ⁻¹	W	A	dB(A)	dB(A)	dB(A)	m ³ /h	Pa	cfm	inH ₂ O
1	Y	400	50	1300	1820	2.86	80	88	92	16845	0	9915	0.00
2	Y	400	50	1300	2455	3.79	74	81	87	14315	300	8425	1.20
3	Y	400	50	1300	2800	4.20	70	78	83	11195	550	6590	2.21
4	Y	400	50	1300	2711	4.17	72	79	84	7810	700	4595	2.81
5	Y	400	50	1100	1082	1.70	76	83	88	14170	0	8340	0.00
6	Y	400	50	1100	1478	2.28	70	77	82	12075	216	7110	0.87
7	Y	400	50	1100	1679	2.58	65	73	79	9445	395	5560	1.59
8	Y	400	50	1100	1611	2.48	68	75	80	6565	498	3865	2.00
9	Y	400	50	900	593	0.93	71	78	83	11590	0	6825	0.00
10	Y	400	50	900	809	1.25	65	72	77	9880	145	5815	0.58
11	Y	400	50	900	920	1.41	60	68	74	7730	264	4550	1.06
12	Y	400	50	900	882	1.36	62	70	75	5375	333	3160	1.34
13	Y	400	50	700	279	0.44	64	72	76	9015	0	5305	0.00
14	Y	400	50	700	381	0.59	58	66	71	7685	88	4525	0.35
15	Y	400	50	700	433	0.66	54	62	67	6010	160	3540	0.64
16	Y	400	50	700	415	0.64	56	63	69	4180	201	2460	0.81

Conn. = Connection · U = Supply voltage · f = Frequency · n = Speed (rpm) · P_{ed} = Power input · I = Current draw · LpA_{in} = Sound pressure level inlet side · LwA_{in} = Sound power level inlet side · LwA_{out} = Sound power level outlet side · q_v = Air flow · P_{fs} = Pressure increase

