

# EC centrifugal module - RadiPac

backward curved, single inlet

in cube design

K3G630-AT09-01 ebmpapst Datasheet

sales@fansco.com

www.fansco.com

Limited partnership · Headquarters Muldingen  
County court Stuttgart · HRA 590344

General partner Elektrobau Muldingen GmbH · Headquarters Muldingen  
County court Stuttgart · HRB 590142

## Nominal data

Type	K3G630-AT09-01	
Motor	M3G200-QA	
Phase		3~
Nominal voltage	VAC	400
Nominal voltage range	VAC	380 .. 480
Frequency	Hz	50/60
Type of data definition		ml
Speed (rpm)	min <sup>-1</sup>	2200
Power input	W	13750
Current draw	A	21.0
Min. ambient temperature	°C	-40
Max. ambient temperature	°C	40

ml = Max. load · me = Max. efficiency · fa = Running at free air · cs = Customer specs · cu = Customer unit  
Subject to alterations



## Technical features

Mass	148 kg
Size	630 mm
Motor size	200
Surface of rotor	Coated in black
Material of electronics housing	Die-cast aluminium, coated in black
Material of impeller	Aluminium sheet
Material of inlet nozzle	Sheet steel, galvanised and plastic-coated in light grey (RAL 7035)
Material of support structure	Sheet steel, galvanised and plastic-coated in light grey (RAL 7035)
Number of blades	7
Direction of rotation	Clockwise, seen on rotor
Type of protection	IP55
Insulation class	"F"
Humidity (F) / environmental protection class (H)	H1
Note ambient temperature	Occasional start-up between -40 °C and -25 °C is permissible. For continuous operation at ambient temperatures below -25 °C (e.g. refrigeration applications), a fan version with special low-temperature bearings must be used.
Max. permissible ambient motor temp. (transp./ storage)	+80 °C
Min. permissible ambient motor temp. (transp./storage)	-40 °C
Mounting position	Shaft horizontal (base mounting only); rotor on top or rotor on bottom on request
Condensation drainage holes	Rotor-side
Operation mode	S1
Motor bearing	Ball bearing
Technical features	<ul style="list-style-type: none"> <li>- Output 10 VDC, max. 10 mA</li> <li>- Output 20 VDC, max. 50 mA</li> <li>- Output for slave 0-10 V</li> <li>- Operation and alarm display</li> <li>- Input for sensor 0-10 V or 4-20 mA</li> <li>- External 24 V input (programming)</li> <li>- External release input</li> <li>- Alarm relay</li> <li>- Integrated PID controller</li> <li>- Output limit</li> <li>- Motor current limit</li> <li>- PFC, passive</li> <li>- RS485 MODBUS RTU</li> <li>- Soft start</li> <li>- Control input 0-10 VDC / PWM</li> <li>- Control interface with SELV potential safely disconnected from the mains</li> <li>- Temperature derating</li> <li>- Over-temperature protected electronics / motor</li> <li>- Line undervoltage / phase failure detection</li> </ul>
EMC interference immunity	Acc. to EN 61000-6-2 (industrial environment)
EMC interference emission	Acc. to EN 61000-6-4 (industrial environment)
Touch current acc. IEC 60990 (measuring network Fig. 4, TN system)	<= 3.5 mA
Electrical connection	Terminal box

# EC centrifugal module - RadiPac

backward curved, single inlet

in cube design

<b>Motor protection</b>	Reverse polarity and locked-rotor protection
<b>Safety classification</b>	I; If a protective earth is connected by the customer This component to be built-in can have several local protection class ratings. The specification refers to the basic design of this component. The final protection class is based on the intended installation and connection of the component.
<b>Product conforming to standard</b>	EN 61800-5-1
<b>Note on CE</b>	Operation only permitted outside the European Economic Area
<b>Approval</b>	UL 1004-7 + 60730-1; EAC; CSA C22.2 no. 77 + CAN/CSA-E60730-1



# EC centrifugal module - RadiPac

backward curved, single inlet  
in cube design

## Product drawing

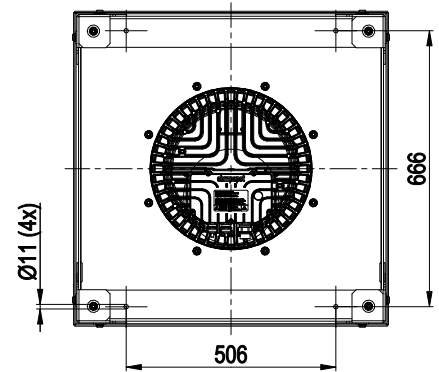
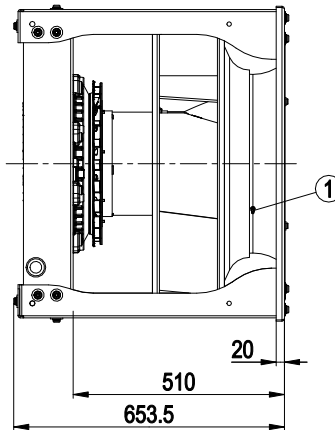
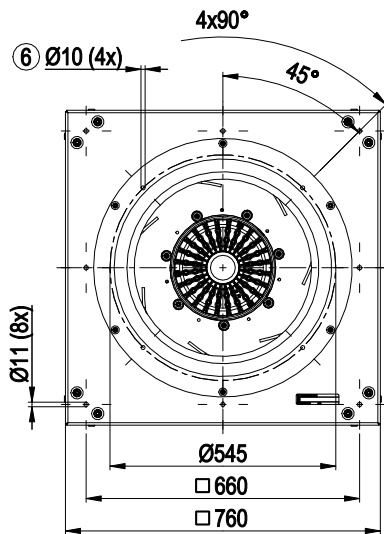
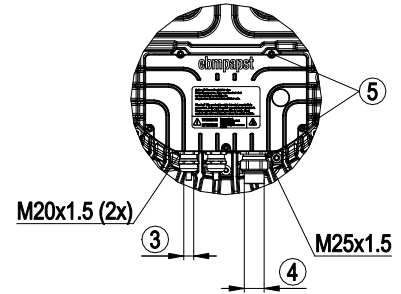
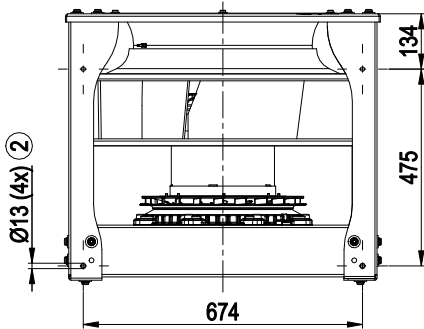

- |   |  |
|---|--|
| 1 | Inlet nozzle with pressure tap (k-factor: 438)                                   |
| 2 | Screw-on position for vibration-absorbing elements, tightening torque max. 40 Nm |
| 3 | Cable diameter min. 5 mm, max. 13 mm, tightening torque 6±0.9 Nm                 |
| 4 | Cable diameter min. 16 mm, max. 20.5 mm, tightening torque 6±0.9 Nm              |
| 5 | Tightening torque 3.5±0.5 Nm   |
| 6 | Attachment holes for FlowGrid 00630-2-2957 (not included in scope of delivery)   |



# EC centrifugal module - RadiPac

backward curved, single inlet

in cube design

## Connection screen

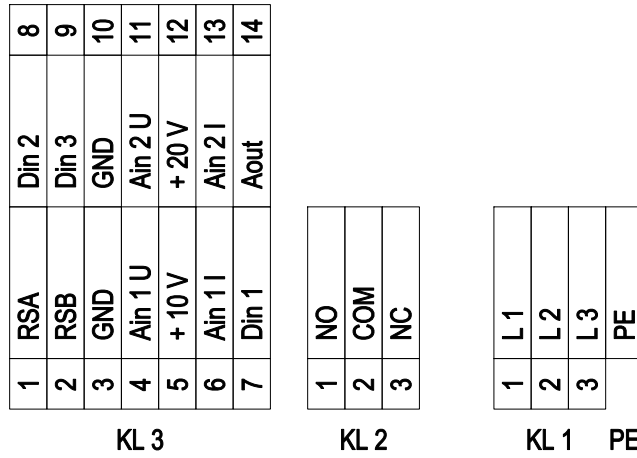

No.	Conn.	Designation	Function / assignment
KL 1	1	L1	Mains supply connection, supply voltage 3-phase 380-480 VAC; 50/60 Hz
KL 1	2	L2	Mains supply connection, supply voltage 3-phase 380-480 VAC; 50/60 Hz
KL 1	3	L3	Mains supply connection, supply voltage 3-phase 380-480 VAC; 50/60 Hz
PE		PE	Earth connection, PE connection
KL 2	1	NO	Status relay, floating status contact; normally open; make for failure
KL2	2	COM	Status relay; floating status contact; changeover contact; common connection; contact rating 250 VAC / max. 2 A (AC1) / min. 10 mA
KL2	3	NC	Status relay, floating status contact; break for failure
KL 3	1	RSA	Bus connection RS485; RSA; MODBUS RTU
KL 3	2	RSB	Bus connection RS485; RSB; MODBUS RTU
KL 3	3 / 10	GND	Reference ground for control interface
KL 3	4	Ain1 U	Analogue input 1 (set value); 0-10 V; Ri= 100 kΩ; parametrisable curves; only usable as alternative to input Ain1 I
KL 3	5	+ 10 V	Fixed voltage output 10 VDC; + 10 V +/-3%; max. 10 mA; short circuit proof; power supply for ext. devices (e.g. potentiometer)
KL 3	6	Ain1 I	Analogue input 1 (set value); 4-20 mA; Ri= 100 Ω; parametrisable curves; only usable as alternative to input Ain1 U
KL 3	7	Din1	Digital input 1: enabling of electronics; enabling: open pin or applied voltage 5 to 50 VDC; disabling: bridge to GND or applied voltage < 1 VDC; reset function: triggers software reset after a level change to <1 V
KL 3	8	Din2	Digital input 2: parameter set switch 1/2; according to EEPROM setting, the valid/used parameter set is selectable per BUS or per digital input DIN2. Parameter set 1: open pin or applied voltage 5 to 50 VDC; parameter set 2: bridge to GND or applied voltage < 1 VDC
KL 3	9	Din3	Digital input 3: Control characteristic of the integrated controller; according to EEPROM setting, the control characteristic of the integrated controller is normally/inversely selectable per BUS or per digital input; normal: open pin or applied voltage 5 to 50 VDC (control deviation = actual sensor value - set value) inverse: bridge to GND or applied voltage < 1 VDC (control deviation = set value - actual sensor value)
KL 3	11	Ain2 U	Analogue input 2; actual sensor value 0-10 V; Ri= 100 kΩ; parametrisable curve; only usable as alternative to input Ain2 I
KL 3	12	+ 20 V	Fixed voltage output 20 VDC; + 20V +25/-10%; max. 50 mA; short circuit proof; supply voltage for ext. devices (e.g. sensors)
KL 3	13	Ain2 I	Analogue input 2; actual sensor value 4-20 mA; Ri= 100 Ω; parametrisable curve; only usable as alternative to input Ain2 U
KL 3	14	Aout	Analogue output 0-10 V; max. 5 mA; output of the actual motor control factor (output voltage of electronics)/ of the actual motor speed. Parametrisable curve.



## Charts: Air flow 50 Hz

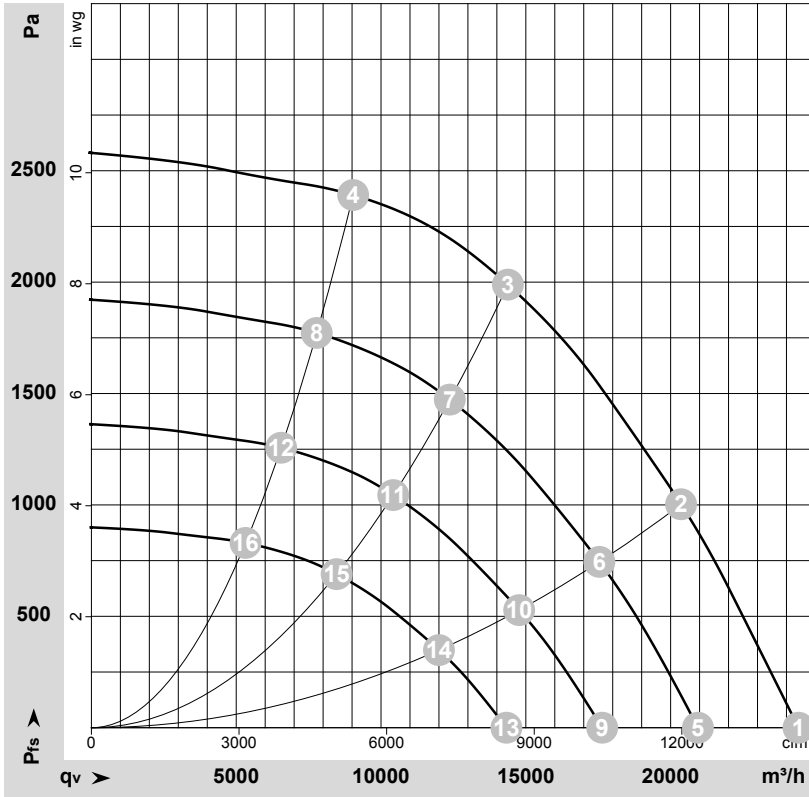

$\rho = 1.15 \text{ kg/m}^3 \pm 2 \%$

Measurement: LU-174526-1

Air performance measured as per ISO 5801 Installation category A. For detailed information on the measuring set-up, please contact ebmpapst. Suction-side noise levels: LwA measured as per ISO 13347 / LpA measured with 1m distance to fan axis. The values given are valid under the measuring conditions mentioned above and may vary according to the actual installation situation. With any deviation from the standard set-up, the specific values have to be checked and reviewed with the unit installed.

## Measured values

	Conn.	U	f	n	P <sub>ed</sub>	I	LpA <sub>in</sub>	LwA <sub>in</sub>	LwA <sub>out</sub>	q <sub>v</sub>	P <sub>fs</sub>	q <sub>v</sub>	P <sub>fs</sub>
		V	Hz	min <sup>-1</sup>	W	A	dB(A)	dB(A)	dB(A)	m <sup>3</sup> /h	Pa	cfm	in. wg
1	3~	400	50	2200	8678	13.55	98	107	111	24415	0	14370	0.00
2	3~	400	50	2200	12002	18.49	94	100	104	20360	1000	11985	4.01
3	3~	400	50	2200	13750	21.00	86	94	100	14380	2000	8465	8.03
4	3~	400	50	2200	12352	18.92	92	99	102	9040	2400	5320	9.64
5	3~	400	50	1900	5477	8.55	94	103	107	20945	0	12325	0.00
6	3~	400	50	1900	7670	11.82	90	96	101	17540	747	10325	3.00
7	3~	400	50	1900	8744	13.38	82	90	96	12375	1475	7285	5.92
8	3~	400	50	1900	7881	12.07	88	95	99	7780	1776	4580	7.13
9	3~	400	50	1600	3271	5.11	90	99	103	17635	0	10380	0.00
10	3~	400	50	1600	4581	7.06	85	92	96	14770	530	8695	2.13
11	3~	400	50	1600	5222	7.99	78	86	92	10420	1046	6135	4.20
12	3~	400	50	1600	4706	7.21	84	91	94	6550	1260	3855	5.06
13	3~	400	50	1300	1754	2.74	84	94	98	14330	0	8435	0.00
14	3~	400	50	1300	2457	3.78	80	86	91	12000	350	7065	1.41
15	3~	400	50	1300	2801	4.29	73	81	87	8465	691	4985	2.77
16	3~	400	50	1300	2524	3.87	78	85	89	5325	832	3135	3.34

Conn. = Connection · U = Supply voltage · f = Frequency · n = Speed (rpm) · P<sub>ed</sub> = Power input · I = Current draw · LpA<sub>in</sub> = Sound pressure level inlet side · LwA<sub>in</sub> = Sound power level inlet side  
 LwA<sub>out</sub> = Sound power level outlet side · q<sub>v</sub> = Air flow · P<sub>fs</sub> = Pressure increase

