

K3G630-AR02-62 ebmpapst Datasheet

sales@fansco.com

www.fansco.com

Limited partnership · Headquarters Mulfingen
County court Stuttgart · HRA 590344General partner Elektrobau Mulfingen GmbH · Headquarters Mulfingen
County court Stuttgart · HRB 590142

Nominal data

Type	K3G630-AR02-62	
Motor	M3G200-HF	
Phase		3~
Nominal voltage	VAC	400
Nominal voltage range	VAC	380 .. 480
Frequency	Hz	50/60
Type of data definition		ml
Speed (rpm)	min ⁻¹	1500
Power input	W	6750
Current draw	A	10.3
Min. ambient temperature	°C	-25
Max. ambient temperature	°C	50

ml = Max. load · me = Max. efficiency · fa = Running at free air · cs = Customer specs · cu = Customer unit
Subject to alterations

Data according to ErP directive

		Actual	Request 2015			
01 Overall efficiency η_{es}	%	63.5	60.2	09 Power input P_{ed}	kW	6.76
02 Measurement category		A		09 Air flow q_v	m ³ /h	14635
03 Efficiency category		Static		09 Pressure increase p_{fs}	Pa	1016
04 Efficiency grade N		65.3	62	10 Speed (rpm) n	min ⁻¹	1505
05 Variable speed drive		Yes		11 Specific ratio [*]		1.01

Data definition with optimum efficiency.

The ErP data is determined using a motor-impeller combination in a standardised measurement configuration.

^{*} Specific ratio = $1 + p_{fs} / 100\,000\text{ Pa}$

LU-141703



Technical features

Mass	130 kg
Size	630 mm
Surface of rotor	Coated in black
Material of electronics housing	Die-cast aluminium
Material of impeller	Aluminium sheet
Material of inlet nozzle	Sheet steel, galvanised and plastic-coated in light grey (RAL 7035)
Material of support structure	Sheet steel, galvanised and plastic-coated in light grey (RAL 7035)
Number of blades	7
Direction of rotation	Clockwise, seen on rotor
Type of protection	IP 54
Insulation class	"F"
Humidity (F)/environmental protection class (H)	F4-1
Note ambient temperature	Occasional start-up between -40°C and -25°C is permissible. For continuous operation at ambient temperatures below -25°C (e.g. refrigeration applications) we recommend our fan version with special low-temperature bearings.
Max. permissible ambient motor temp. (transp./ storage)	+80 °C
Min. permissible ambient motor temp. (transp./storage)	-40 °C
Mounting position	Shaft horizontal (base mounting only)
Condensate discharge holes	Rotor-side
Operation mode	S1
Motor bearing	Ball bearing
Technical features	<ul style="list-style-type: none"> - Output 10 VDC, max. 10 mA - Output 20 VDC, max. 50 mA - Output for slave 0-10 V - Operation and alarm display - Input for sensor 0-10 V or 4-20 mA - External 24 V input (programming) - External release input - Alarm relay - Integrated PID controller - Motor current limit - PFC, passive - RS485 MODBUS RTU - Soft start - Control input 0-10 VDC / PWM - Control interface with SELV potential safely disconnected from the mains - Over-temperature protected electronics / motor - Line undervoltage / phase failure detection
EMC interference immunity	Acc. to EN 61000-6-2 (industrial environment)
EMC interference emission	Acc. to EN 61000-6-4 (industrial environment)
Touch current acc. IEC 60990 (measuring network Fig. 4, TN system)	<= 3.5 mA
Electrical leads	Via terminal box
Motor protection	Reverse polarity and locked-rotor protection
Protection class	I (if protective earth is connected by customer)

K3G630-AR02-62

EC centrifugal module

backward curved, single inlet
in cube design

Product conforming to standard	EN 61800-5-1; CE
Approval	EAC



EC centrifugal module

backward curved, single inlet
in cube design

Product drawing

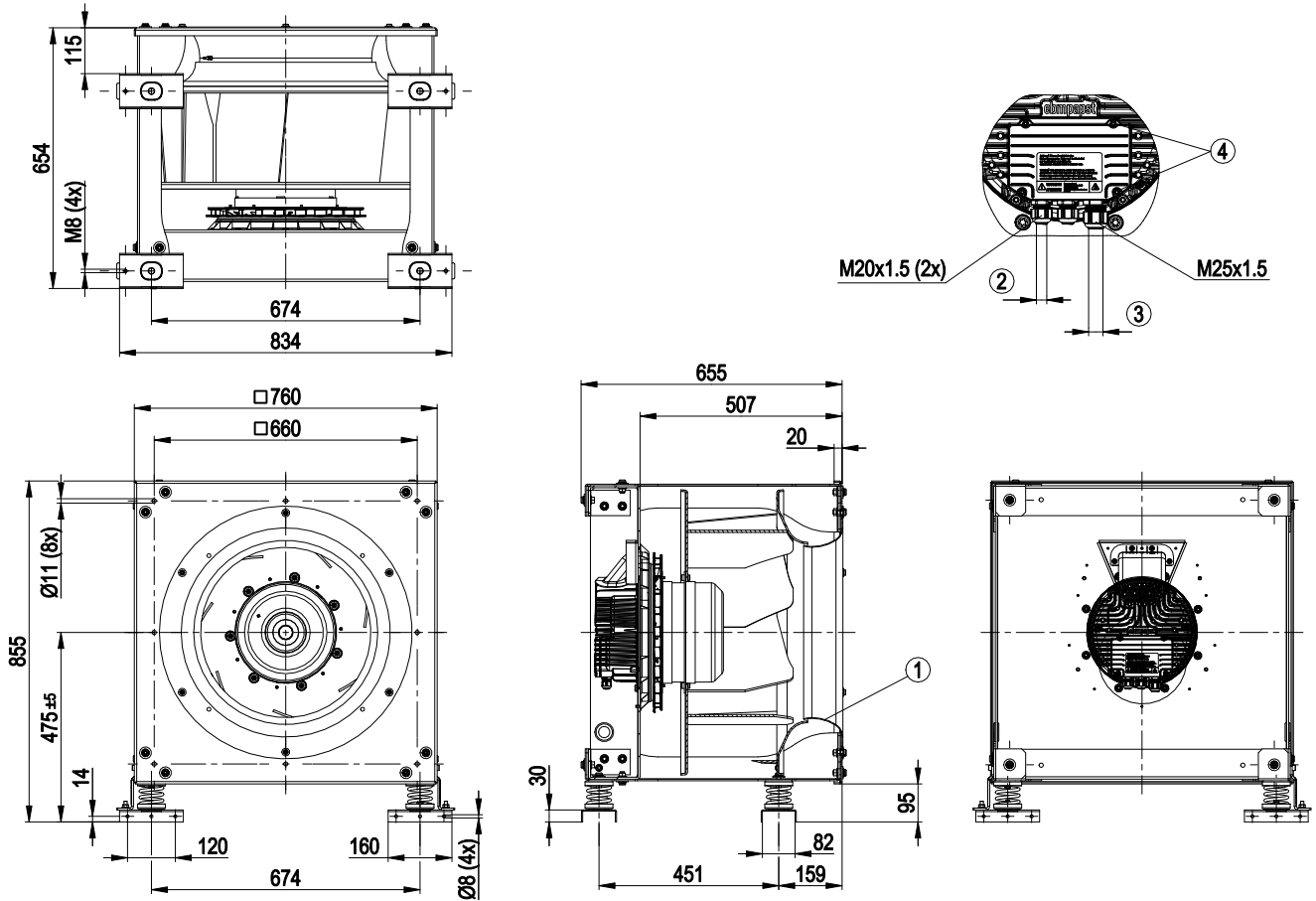

1	Inlet nozzle with pressure tap (k-factor: 545)
2	Cable diameter min. 4 mm, max. 10 mm, tightening torque 4 ± 0.6 Nm
3	Cable diameter min. 9 mm, max. 16 mm, tightening torque 6 ± 0.9 Nm
4	Tightening torque 3.5 ± 0.5 Nm



EC centrifugal module

backward curved, single inlet
in cube design

Connection screen

	8		
	9	Din 2	
	10	Din 3	
	11	GND	
	12	Ain 2 U	
	13	+ 20 V	
	14	Ain 2 I	
		Aout	
1		RSA	
2		RSB	
3		GND	
4		Ain 1 U	
5		+ 10 V	
6		Ain 1 I	
7		Din 1	

KL 3

1	NO
2	COM
3	NC

KL 2

PE

PE

1	L1
2	L2
3	L3

KL 1

No.	Conn.	Designation	Function / assignment
KL 1	1	L1	Mains supply connection, supply voltage 3~380-480 VAC; 50/60 Hz
KL 1	2	L2	Mains supply connection, supply voltage 3~380-480 VAC; 50/60 Hz
KL 1	3	L3	Mains supply connection, supply voltage 3~380-480 VAC; 50/60 Hz
PE		PE	Earth connection, PE connection
KL 2	1	NO	Status relay, floating status contact; normally open; close with error
KL2	2	COM	Status relay; floating status contact; changeover contact; common connection; contact rating 250 VAC / max. 2 A (AC1) / min. 10 mA
KL2	3	NC	Status relay, floating status contact; break with error
KL 3	1	RSA	Bus connection RS-485, RSA, MODBUS RTU; SELV
KL 3	2	RSB	Bus connection RS-485, RSB, MODBUS RTU; SELV
KL 3	3 / 10	GND	Signal ground for control interface; SELV
KL 3	4	Ain1 U	Analogue input 1, set value: 0-10 V, Ri = 100 kΩ, parametrisable curve, only usable as alternative to input Ain1; SELV
KL 3	5	+ 10 V	Fixed voltage output 10 VDC, +10 V ±3%, max. 10 mA, short-circuit-proof, power supply for external devices (e.g. potentiometer), SELV
KL 3	6	Ain1 I	Analogue input 1, set value: 4-20 mA; Ri = 100 Ω, parametrisable curve, only usable as alternative to input Ain1 U; SELV
KL 3	7	Din1	Digital input 1: enabling of electronics, enabling: open pin or applied voltage 5-50 VDC disabling: bridge to GND or applied voltage <1 VDC reset function: triggers software reset after a level change to <1 VDC; SELV
KL 3	8	Din2	Digital input 2: parameter set switch 1/2, according to EEPROM setting, the valid/used parameter set can be selected via bus or via digital input DIN2. Parameter set 1: open pin or applied voltage 5-50 VDC Parameter set 2: bridge to GND or applied voltage <1 VDC; SELV
KL 3	9	Din3	Digital input 3: controller function of integrated controller, according to EEPROM setting, the controller function of the integrated controller is normally/inversely selectable per bus or per digital input normal: open pin or applied voltage 5-50 VDC inverse: bridge to GND or applied voltage <1 VDC; SELV
KL 3	11	Ain2 U	Analogue input 2, actual value: 0-10 V, Ri = 100 kΩ, parametrisable curve, only usable as alternative to input Ain2; SELV
KL 3	12	+ 20 V	Fixed voltage output 20 VDC, +20 V ±25/-10%, max. 50 mA, short-circuit-proof, power supply for external devices (e.g. sensors); SELV



EC centrifugal module

backward curved, single inlet

in cube design

No.	Conn.	Designation	Function / assignment
KL 3	13	Ain2 I	Analogue input 2, actual value: 4-20 mA, $R_i = 100 \Omega$, parametrisable curve, only usable as alternative to input Ain2 U; SELV
KL 3	14	Aout	Analogue output 0-10 VDC, max. 5 mA, output of the current motor level control coefficient / motor speed parametrisable curve; SELV



Charts: Air flow 50 Hz

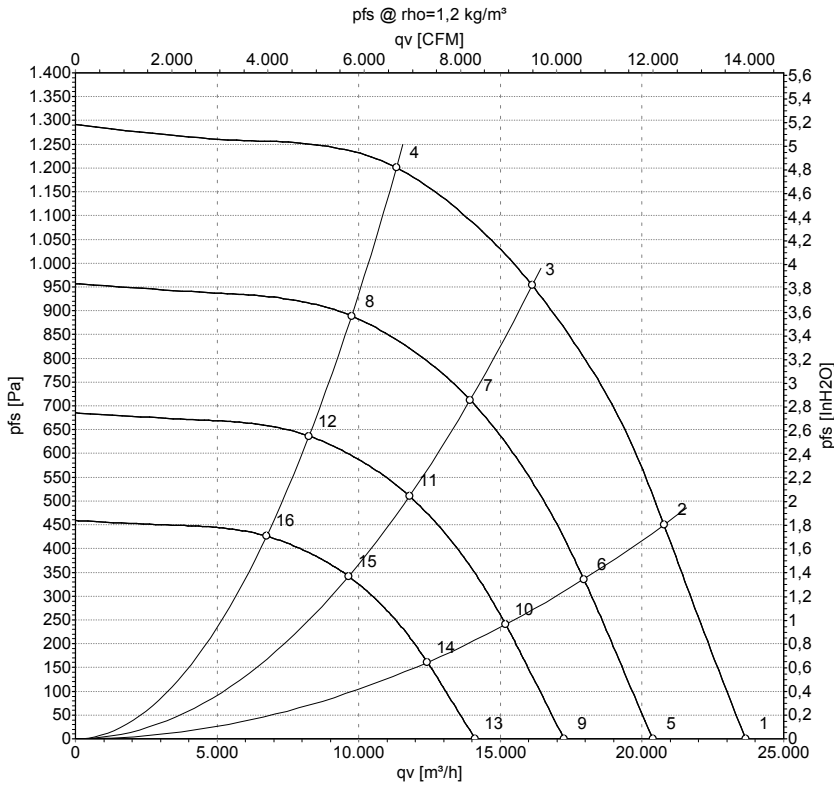

Measurement: LU-141703-1

Air performance measured as per ISO 5801 Installation category A. For detailed information on the measuring set-up, please contact ebm-papst. Suction-side noise levels: LwA measured as per ISO 13347 / LpA measured with 1m distance to fan axis. The values given are valid under the measuring conditions mentioned above and may vary according to the actual installation situation. With any deviation from the standard set-up, the specific values have to be checked and reviewed with the unit installed.

Measured values

	U	f	n	P _{ed}	I	LpA _{in}	LwA _{in}	LwA _{out}	q _v	P _{fs}	q _v	P _{fs}
	V	Hz	min ⁻¹	W	A	dB(A)	dB(A)	dB(A)	m ³ /h	Pa	cfm	inH ₂ O
1	400	50	1500	4523	7.00	88	97	103	23655	0	13925	0.00
2	400	50	1500	5763	8.87	83	92	97	20775	450	12225	1.81
3	400	50	1500	6750	10.30	80	88	93	16120	950	9485	3.81
4	400	50	1500	6333	9.69	80	88	94	11330	1200	6670	4.82
5	400	50	1300	2892	4.47	84	93	99	20380	0	11995	0.00
6	400	50	1300	3720	5.72	79	88	94	17945	338	10560	1.36
7	400	50	1300	4354	6.68	76	84	90	13935	713	8200	2.86
8	400	50	1300	4027	6.16	76	84	91	9750	896	5735	3.60
9	400	50	1100	1752	2.71	80	89	95	17245	0	10150	0.00
10	400	50	1100	2253	3.47	75	84	89	15185	242	8935	0.97
11	400	50	1100	2638	4.04	72	80	85	11790	510	6940	2.05
12	400	50	1100	2440	3.73	72	80	86	8250	642	4855	2.58
13	400	50	900	960	1.48	75	84	90	14110	0	8305	0.00
14	400	50	900	1234	1.90	70	79	84	12425	162	7310	0.65
15	400	50	900	1445	2.22	67	75	80	9645	342	5675	1.37
16	400	50	900	1336	2.04	67	75	81	6750	429	3970	1.72

U = Supply voltage · f = Frequency · n = Speed (rpm) · P_{ed} = Power input · I = Current draw · LpA_{in} = Sound pressure level inlet side · LwA_{in} = Sound power level inlet side · LwA_{out} = Sound power level outlet side
 q_v = Air flow · p_{fs} = Pressure increase

