

EC centrifugal module

backward curved, single inlet

with support plate

K3G630-AA08-03 ebmpapst Datasheet

sales@fansco.com

www.fansco.com

Limited partnership · Headquarters Mulfingen
County court Stuttgart · HRA 590344

General partner Elektrobau Mulfingen GmbH · Headquarters Mulfingen
County court Stuttgart · HRB 590142



Nominal data

Type	K3G630-AA08-03	
Motor	M3G150-FF	
Phase		3~
Nominal voltage	VAC	400
Nominal voltage range	VAC	380 .. 480
Frequency	Hz	50/60
Type of data definition		ml
Speed	min ⁻¹	1000
Power input	W	1700
Current draw	A	2.6
Min. ambient temperature	°C	-25
Max. ambient temperature	°C	60

ml = max. load · me = max. efficiency · fa = running at free air · cs = customer specs · cu = customer unit
Subject to alterations

Data according to ErP directive

		Actual	Request 2013	Request 2015
Installation category	A			
Efficiency category	Static			
Variable speed drive	Yes			
Specific ratio*	1.00			
Overall efficiency η_{es}		57.2	49.9	53.9
Efficiency grade N		65.3	58	62
Power input P_{ed}	kW	1.68		
Air flow q_v	m ³ /h	9005		
Pressure increase p_{fs}	Pa	359		
Speed n	min ⁻¹	1005		

Data established at point of optimum efficiency

* Specific ratio = $1 + p_{fs} / 100\,000\text{ Pa}$



Technical features

Mass	50.4 kg
Size	630 mm
Surface of rotor	Coated in black
Material of electronics housing	Die-cast aluminium
Material of impeller	Aluminium sheet
Material of mounting plate	Sheet steel, hot-dip galvanised
Material of distancing profiles	Aluminium
Material of inlet nozzle	Sheet steel, hot-dip galvanised
Number of blades	6
Direction of rotation	Clockwise, seen on rotor
Type of protection	IP 54
Insulation class	"F"
Humidity class	F4-1
Max. permissible ambient motor temp. (transp./ storage)	+80 °C
Min. permissible ambient motor temp. (transp./storage)	-40 °C
Mounting position	Shaft horizontal or rotor on bottom; rotor on top on request
Condensate discharge holes	Rotor-side
Operation mode	S1
Motor bearing	Ball bearing
Technical features	<ul style="list-style-type: none"> - PFC, passive - Control input 0-10 VDC / PWM - Over-temperature protected electronics / motor - Alarm relay - Integrated PID controller - Input for sensor 0-10 V or 4-20 mA - Output for slave 0-10 V - RS485 ebmBUS - Motor current limit - Soft start - Line undervoltage / phase failure detection - Output 10 VDC, max. 10 mA - Output 20 VDC, max. 50 mA
EMC interference immunity	Acc. to EN 61000-6-2
EMC interference emission	Acc. to EN 61000-6-3
Touch current acc. IEC 60990 (measuring network Fig. 4, TN system)	<= 3.5 mA
Electrical leads	Via terminal box
Motor protection	Reverse polarity and locked-rotor protection
Protection class	I (if protective earth is connected by customer)
Product conforming to standard	EN 61800-5-1; CE
Approval	VDE; GOST; UL 2111; CSA C22.2 Nr.77

EC centrifugal module

backward curved, single inlet
with support plate

Product drawing

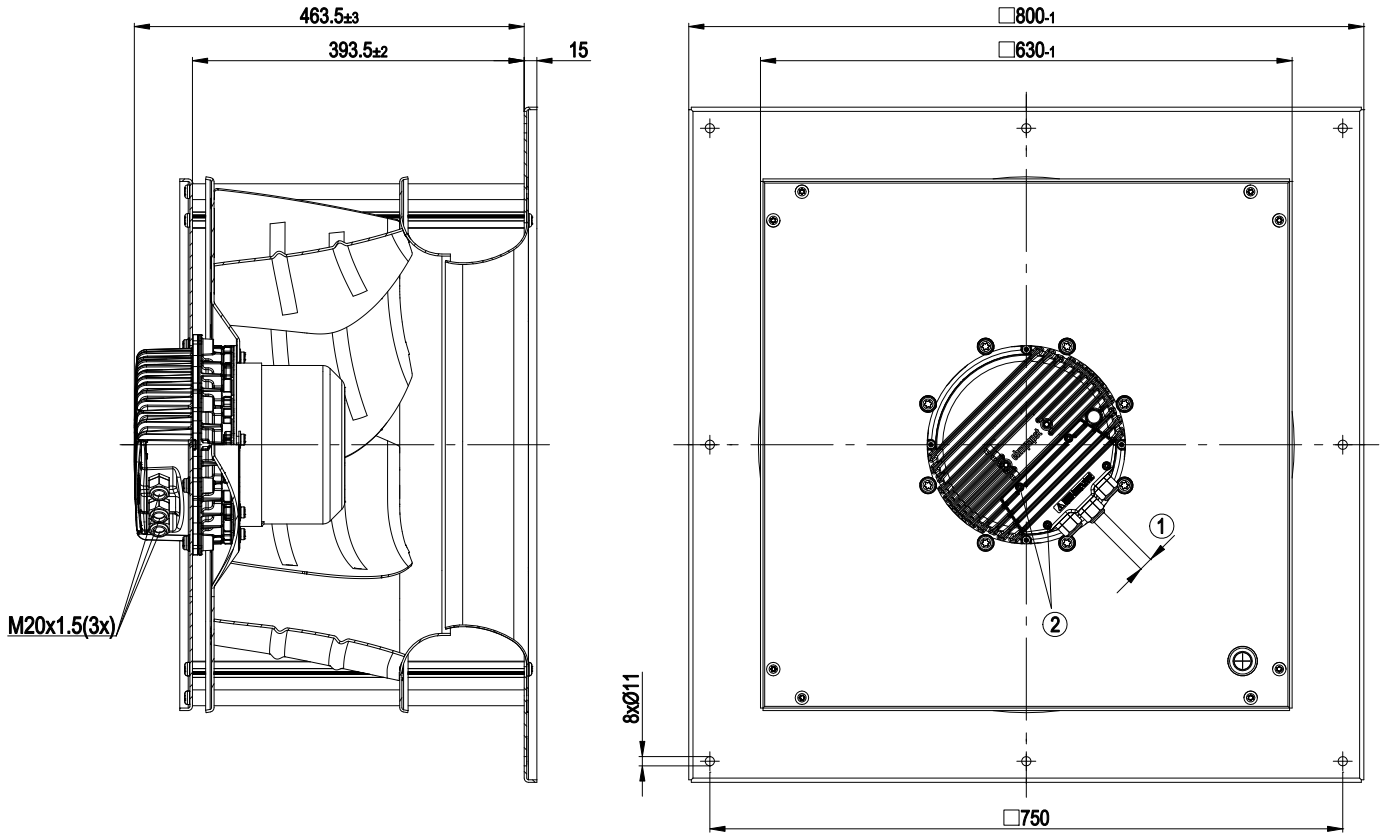

- 1 Cable diameter: min. 4 mm, max. 10 mm, tightening torque: 4±0.6 Nm
- 2 Tightening torque 3.5±0.5 Nm



EC centrifugal module

backward curved, single inlet
with support plate

Connection screen

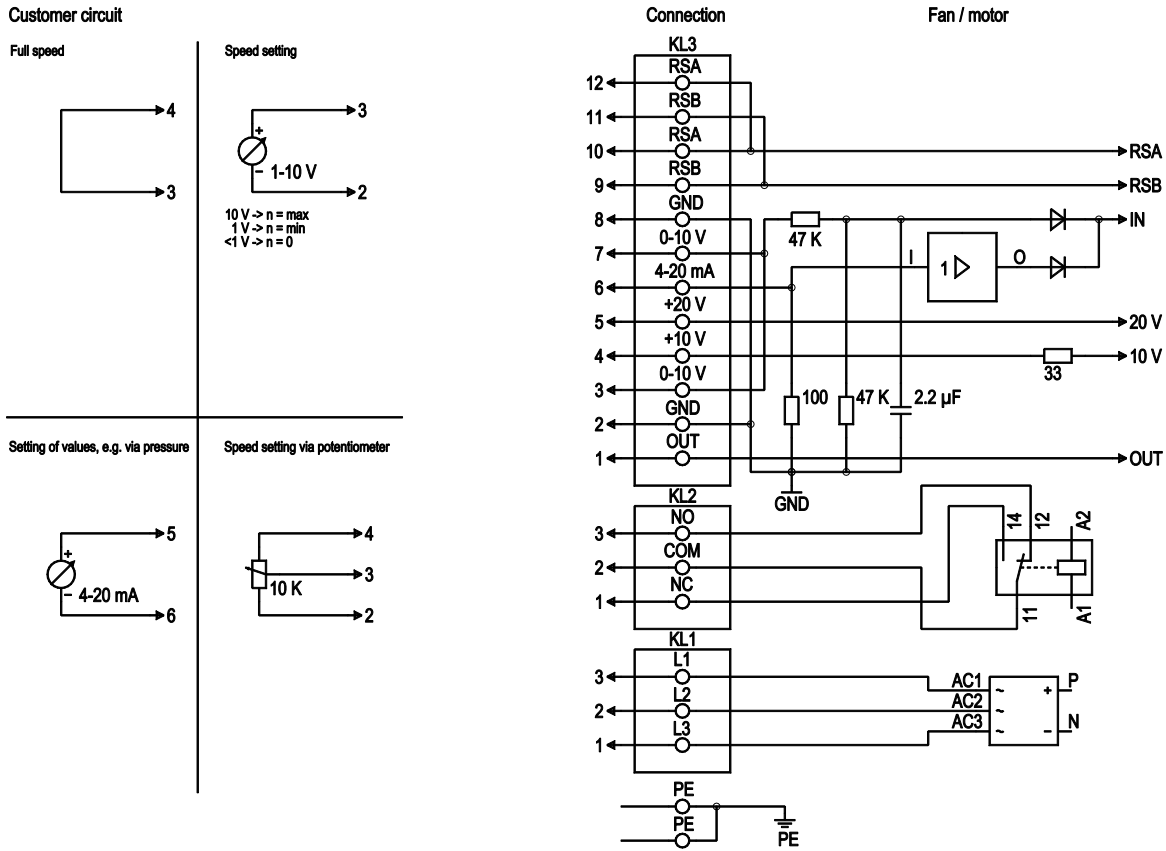

No.	Pin	Signal	Function / assignment
PE		PE	Protective earth connection
KL1	1, 2, 3	L1, L2, L3	Supply voltage, 50/60 Hz
KL2	1	NC	Floating status message contact, normally closed connection
KL2	2	COM	Floating status message contact, changeover contact, common connection (2 A, max. 250 VAC, min. 10 mA, AC1)
KL2	3	NO	Floating status message contact, normally open connection
KL3	1	OUT	Analog output, 0-10 VDC, max. 3 mA, SELV, output of the current level control coefficient: 1 V equates to 10 % level control coefficient. 10 V equate to 100 % level control coefficient.
KL3	2, 8	GND	Reference mass for control interface, SELV
KL3	3, 7	0-10 V	Use control / actual value input 0-10 VDC, impedance 100 kΩ only as alternative to 4-20 mA input, SELV
KL3	4	+10 V	Voltage output 10 VDC (+/-3 %), max. 10 mA, supply voltage for ext. devices (e.g. potentiometers), SELV
KL3	5	+20 V	Voltage output 20 VDC (+25 %/-10 %), max. 50 mA, supply voltage for ext. devices (e.g. sensors), SELV
KL3	6	4-20 mA	Use control / actual value input 4-20 mA, impedance 100 Ω, only as alternative to 0-10 V input, SELV
KL3	9, 11	RSB	RS485 interface for ebmBus, RSB, SELV
KL3	10, 12	RSA	RS485 interface for ebmBus, RSA, SELV



Charts: Air flow 50 Hz

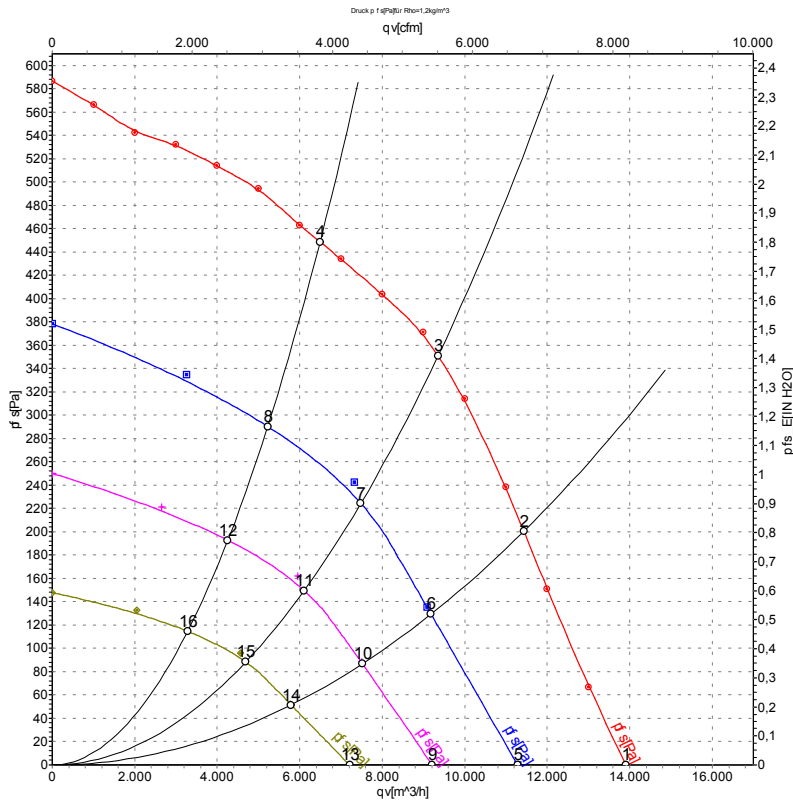

Measurement: LU-109100
 Measurement: LU-119157
 Measurement: LU-119158
 Measurement: LU-119159

Air performance measured as per ISO 5801 Installation category A. For detailed information on the measuring set-up, please contact ebm-papst. Suction-side noise levels: LwA measured as per ISO 13347 / LpA measured with 1m distance to fan axis. The values given are valid under the measuring conditions mentioned above and may vary according to the actual installation situation. With any deviation from the standard set-up, the specific values have to be checked and reviewed with the unit installed.

Measured values

	Conn.	U	f	n	P _{ed}	I	LpA _{in}	LwA _{in}	LwA _{out}	qv	p _{fs}
		V	Hz	min ⁻¹	W	A	dB(A)	dB(A)	dB(A)	m ³ /h	Pa
1	Y	400	50	1000	1141	1.74	73	80	85	13910	0
2	Y	400	50	1000	1475	2.23	69	76	82	11430	200
3	Y	400	50	1000	1700	2.60	68	75	81	9355	350
4	Y	400	50	1000	1543	2.33	68	76	82	6495	450
5	Y	400	50	800	529	0.84	67	74	79	11280	0
6	Y	400	50	800	706	1.10	63	70	76	9185	130
7	Y	400	50	800	793	1.24	62	69	75	7480	233
8	Y	400	50	800	706	1.11	62	70	76	5225	290
9	Y	400	50	650	302	0.56	61	68	73	9215	0
10	Y	400	50	650	378	0.66	57	64	70	7520	88
11	Y	400	50	650	421	0.70	56	64	70	6110	155
12	Y	400	50	650	376	0.64	57	64	70	4255	193
13	Y	400	50	500	139	0.29	53	61	66	7210	0
14	Y	400	50	500	178	0.36	50	57	63	5795	51
15	Y	400	50	500	196	0.39	50	57	63	4695	91
16	Y	400	50	500	176	0.36	50	57	63	3280	115

Conn. = Connection · U = Supply voltage · f = Frequency · n = Speed · P_{ed} = Power input · I = Current draw · LpA_{in} = Sound pressure level inlet side · LwA_{in} = Sound power level inlet side
 LwA_{out} = Sound power level outlet side · qv = Air flow · p_{fs} = Pressure increase

