

ebm-papst Ventilator (Shanghai) Co.,Ltd.

No.418, Hua Jing Road, Wai Gao Qiao Free Trade Zone, Pudong

83

K3G560-RB31-71/F04 ebmpapst Datasheet

sales@fansco.com

www.fansco.com

Nominal data

| | | |
|--------------------------|---------------------------|------------|
| Type | K3G560-RB31-71/F04 | |
| Motor | M3G150-IF | |
| Phase | | 3~ |
| Nominal voltage | VAC | 400 |
| Nominal voltage range | VAC | 380 .. 480 |
| Frequency | Hz | 50/60 |
| Method of obtaining data | | ml |
| Speed (rpm) | min ⁻¹ | 1650 |
| Power consumption | W | 2900 |
| Current draw | A | 4.43 |
| Min. ambient temperature | °C | -25 |
| Max. ambient temperature | °C | 55 |

ml = Max. load · me = Max. efficiency · fa = Free air · cs = Customer specification · ce = Customer equipment
Subject to change

Data according to Commission Regulation (EU) 327/2011

| | | Actual | Req. 2015 |
|-----------------------------------|---|--------|-----------|
| 01 Overall efficiency η_{es} | % | 67.9 | 56.4 |
| 02 Measurement category | | A | |
| 03 Efficiency category | | Static | |
| 04 Efficiency grade N | | 73.5 | 62 |
| 05 Variable speed drive | | Yes | |

Data obtained at optimum efficiency level.

The ErP data is determined using a motor-impeller combination in a standardized measurement setup.

| | | |
|-------------------------------|-------------------|------|
| 09 Power consumption P_{ed} | kW | 2.92 |
| 09 Air flow q_v | m ³ /h | 9845 |
| 09 Pressure increase p_{fs} | Pa | 688 |
| 10 Speed (rpm) n | min ⁻¹ | 1645 |
| 11 Specific ratio* | | 1.01 |

* Specific ratio = $1 + p_{fs} / 100\,000\text{ Pa}$ 

Technical description

| | |
|---|---|
| Weight | 42.6 kg |
| Fan size | 560 mm |
| Rotor surface | Painted black |
| Electronics housing material | Die-cast aluminum |
| Impeller material | PP plastic |
| Material of mounting plate | Sheet steel, galvanised |
| Material of support bracket | Steel, coated in black |
| Material of inlet nozzle | Sheet steel, galvanised |
| Number of blades | 6 |
| Direction of rotation | Clockwise, viewed toward rotor |
| Degree of protection | IP55 |
| Insulation class | "F" |
| Moisture (F) / Environmental (H) protection class | F4-1 |
| Ambient temperature note | Occasional start-up between -40°C and -25°C is permissible. For continuous operation at temperatures below -25°C (e.g. refrigeration applications) we recommend our fan design with special low-temperature bearings. |
| Max. permitted ambient temp. for motor (transport/storage) | +80 °C |
| Min. permitted ambient temp. for motor (transport/storage) | -40 °C |
| Installation position | Shaft horizontal or rotor on bottom; rotor on top on request |
| Condensation drainage holes | On rotor side |
| Mode | S1 |
| Motor bearing | Ball bearing |
| Technical features | <ul style="list-style-type: none"> - Output 10 VDC, max. 10 mA - Operation and alarm display - External 24 V input (parameter setting) - External release input - Alarm relay - Integrated PID controller - Motor current limitation - PFC, passive - RS-485 MODBUS-RTU - Soft start - Control input 0-10 VDC / PWM - Control interface with SELV potential safely disconnected from supply - Thermal overload protection for electronics/motor - Line undervoltage / phase failure detection |
| EMC immunity to interference | According to EN 61000-6-2 (industrial environment) |
| EMC interference emission | According to EN 55022 (Class B, household environment) |
| Touch current according to IEC 60990 (measuring circuit Fig. 4, TN system) | <= 3.5 mA |
| Electrical hookup | Via terminal box |
| Motor protection | Reverse polarity and locked-rotor protection |
| Protection class | I (if protective earth is connected by customer to the housing's connection point) |
| Approval | EAC |

Product drawing

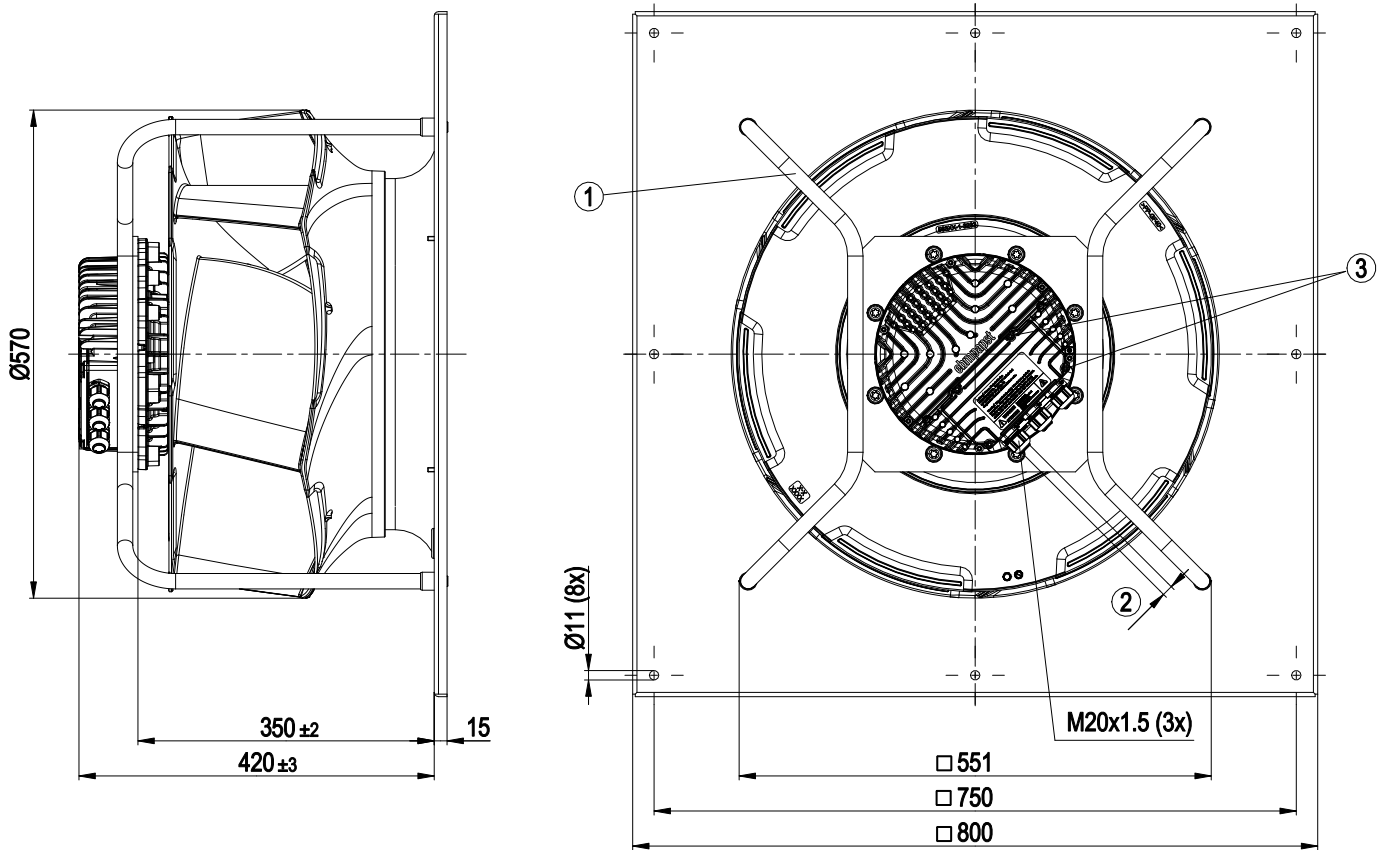

| | |
|---|--|
| 1 | Mounting position: shaft horizontal (install the support struts only vertically as shown in the view!) or rotor on bottom; rotor on top on request |
| 2 | Cable diameter: min. 4 mm, max. 10 mm; tightening torque: 4 ± 0.6 Nm |
| 3 | Tightening torque 3.5 ± 0.5 Nm |

Connection diagram

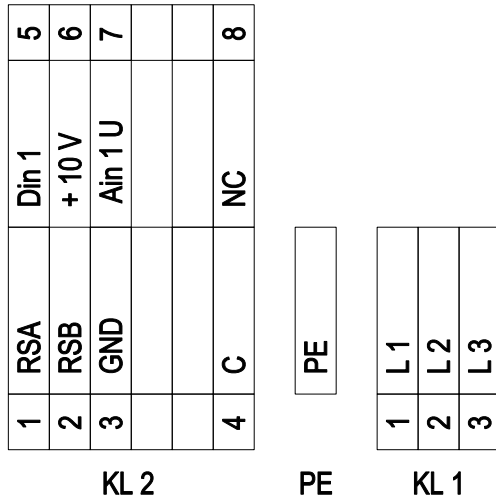

| No. | Conn. | Designation | Function/assignment |
|------|-------|-------------|---|
| KL 1 | 1 | L1 | Supply connection, power supply 3-phase 380-480 VAC, 50/60 Hz |
| KL 1 | 2 | L2 | Supply connection, power supply 3-phase 380-480 VAC, 50/60 Hz |
| KL 1 | 3 | L3 | Supply connection, power supply 3-phase 380-480 VAC, 50/60 Hz |
| PE | | PE | Ground connection, PE connection |
| KL 2 | 1 | RSA | Bus connection RS485, RSA, MODBUS-RTU; SELV |
| KL 2 | 2 | RSB | Bus connection RS485, RSB, MODBUS-RTU; SELV |
| KL 2 | 3 | GND | Reference ground for control interface; SELV |
| KL2 | 4 | C | Status relay, floating status contact, break for failure; contact rating 250 VAC / max. 2 A (AC1) / min. 10 mA |
| KL 2 | 5 | Din1 | Digital input 1 enable electronics, enable: pin open or applied voltage 5-50 VDC disable: bridge to GND or applied voltage < 1 VDC reset function: triggers software reset after a level change to < 1 V; SELV |
| KL 2 | 6 | + 10 V | Fixed voltage output 10 VDC, +10 V ±3%, max. 10 mA, short-circuit-proof, power supply for external devices (e.g. pot); SELV Or: +24 VDC input for parameter setting via MODBUS without line voltage |
| KL 2 | 7 | Ain1 U | Analog input 1 (set value) 0-10 V, Ri = 100 kΩ, adjustable curve; SELV |
| KL2 | 8 | NC | Status relay, floating status contact, break for failure |

Curves: Air performance 50 Hz

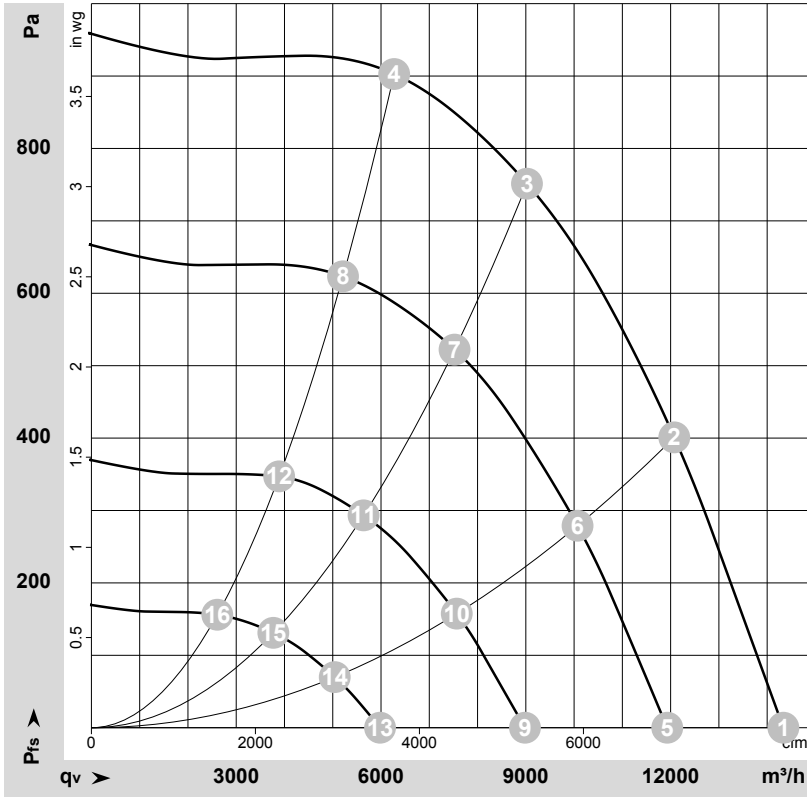

Measured values

| | Wired | U | f | n | P _{ed} | I | LpA _{in} | LwA _{in} | LwA _{out} | q _v | p _{fs} | q _v | p _{fs} |
|----|-------|-----|----|-------------------|-----------------|------|-------------------|-------------------|--------------------|-------------------|-----------------|----------------|-----------------|
| | | V | Hz | min ⁻¹ | W | A | dB(A) | dB(A) | dB(A) | m ³ /h | Pa | cfm | in. wg |
| 1 | Y | 400 | 50 | 1650 | 2030 | 3.17 | 79 | 87 | 90 | 14335 | 0 | 8440 | 0.00 |
| 2 | Y | 400 | 50 | 1650 | 2695 | 4.16 | 73 | 81 | 85 | 12075 | 400 | 7105 | 1.61 |
| 3 | Y | 400 | 50 | 1650 | 2900 | 4.43 | 69 | 77 | 82 | 9025 | 750 | 5310 | 3.01 |
| 4 | Y | 400 | 50 | 1650 | 2769 | 4.28 | 73 | 81 | 85 | 6270 | 900 | 3690 | 3.61 |
| 5 | Y | 400 | 50 | 1375 | 1191 | 1.94 | 75 | 83 | 86 | 11930 | 0 | 7020 | 0.00 |
| 6 | Y | 400 | 50 | 1375 | 1592 | 2.53 | 69 | 77 | 81 | 10070 | 280 | 5930 | 1.12 |
| 7 | Y | 400 | 50 | 1375 | 1705 | 2.70 | 64 | 73 | 77 | 7525 | 522 | 4430 | 2.10 |
| 8 | Y | 400 | 50 | 1375 | 1610 | 2.56 | 68 | 76 | 80 | 5210 | 624 | 3070 | 2.51 |
| 9 | Y | 400 | 50 | 1035 | 534 | 1.07 | 70 | 77 | 80 | 8985 | 0 | 5285 | 0.00 |
| 10 | Y | 400 | 50 | 1035 | 711 | 1.31 | 64 | 71 | 75 | 7570 | 158 | 4455 | 0.63 |
| 11 | Y | 400 | 50 | 1035 | 760 | 1.37 | 57 | 66 | 70 | 5640 | 293 | 3320 | 1.18 |
| 12 | Y | 400 | 50 | 1030 | 711 | 1.31 | 60 | 68 | 72 | 3890 | 347 | 2290 | 1.39 |
| 13 | Y | 400 | 50 | 695 | 189 | 0.60 | 61 | 69 | 72 | 5980 | 0 | 3520 | 0.00 |
| 14 | Y | 400 | 50 | 695 | 242 | 0.67 | 55 | 63 | 66 | 5040 | 70 | 2965 | 0.28 |
| 15 | Y | 400 | 50 | 695 | 258 | 0.69 | 47 | 55 | 60 | 3770 | 131 | 2220 | 0.53 |
| 16 | Y | 400 | 50 | 695 | 244 | 0.67 | 48 | 57 | 61 | 2610 | 156 | 1535 | 0.63 |

Wired = Wiring · U = Power supply · f = Frequency · n = Speed (rpm) · P_{ed} = Power consumption · I = Current draw · LpA_{in} = Sound pressure level intake side · LwA_{in} = Sound power level intake side
 LwA_{out} = Sound power level outlet side · q_v = Air flow · p_{fs} = Pressure increase

