

backward curved, single inlet

with support bracket

K3G560-RA25-76 ebmpapst Datasheet

sales@fansco.com

www.fansco.com

Limited partnership · Headquarters Mulfingen
County court Stuttgart · HRA 590344General partner Elektrobau Mulfingen GmbH · Headquarters Mulfingen
County court Stuttgart · HRB 590142

Nominal data

Type	K3G560-RA25-76	
Motor	M3G150-FF	
Phase		3~
Nominal voltage	VAC	400
Nominal voltage range	VAC	380 .. 480
Frequency	Hz	50/60
Type of data definition		ml
Speed (rpm)	min ⁻¹	1540
Power input	W	2360
Current draw	A	3.65
Min. ambient temperature	°C	-25
Max. ambient temperature	°C	60

ml = Max. load · me = Max. efficiency · fa = Running at free air · cs = Customer specs · cu = Customer unit
Subject to alterations

Data in accordance with ecodesign regulation EU 327/2011

		Actual	Request 2015			
01 Overall efficiency η_{es}	%	65.8	55.4	09 Power input P_{ed}	kW	2.35
02 Measurement category		A		09 Air flow q_v	m ³ /h	8565
03 Efficiency category		Static		09 Pressure increase p_{fs}	Pa	612
04 Efficiency grade N		72.4	62	10 Speed (rpm) n	min ⁻¹	1550
05 Variable speed drive		Yes		11 Specific ratio [*]		1.01

Data definition with optimum efficiency.

The ErP data is determined using a motor-impeller combination in a standardised measurement configuration.

^{*} Specific ratio = $1 + p_{fs} / 100\,000\text{ Pa}$

LU-148925



backward curved, single inlet
with support bracket

Technical features

Mass	42 kg
Size	560 mm
Motor size	150
Surface of rotor	Coated in black
Material of electronics housing	Die-cast aluminium
Material of impeller	PP plastic
Material of mounting plate	Sheet steel, galvanised
Material of support bracket	Steel, coated in black
Material of inlet nozzle	Sheet steel, galvanised
Number of blades	6
Direction of rotation	Clockwise, seen on rotor
Type of protection	IP55
Insulation class	"F"
Humidity (F) / environmental protection class (H)	H1
Max. permissible ambient motor temp. (transp./ storage)	+80 °C
Min. permissible ambient motor temp. (transp./storage)	-40 °C
Mounting position	Refer to product drawing
Condensation drainage holes	Rotor-side
Operation mode	S1
Motor bearing	Ball bearing
Technical features	<ul style="list-style-type: none"> - Output 10 VDC, max. 10 mA - Operation and alarm display - External 24 V input (programming) - External release input - Alarm relay - Integrated PID controller - Motor current limit - PFC, passive - RS485 MODBUS RTU - Soft start - Control input 0-10 VDC / PWM - Control interface with SELV potential safely disconnected from the mains - Over-temperature protected electronics / motor - Line undervoltage / phase failure detection
EMC interference immunity	Acc. to EN 61000-6-2 (industrial environment)
EMC interference emission	Acc. to EN 61000-6-4 (industrial environment)
Touch current acc. IEC 60990 (measuring network Fig. 4, TN system)	<= 3.5 mA
Electrical connection	Terminal box
Motor protection	Reverse polarity and locked-rotor protection
Protection class	I (if protective earth is connected by customer)
Product conforming to standard	EN 61800-5-1; CE
Approval	EAC



EC centrifugal module - RadiCal

backward curved, single inlet
with support bracket

Product drawing

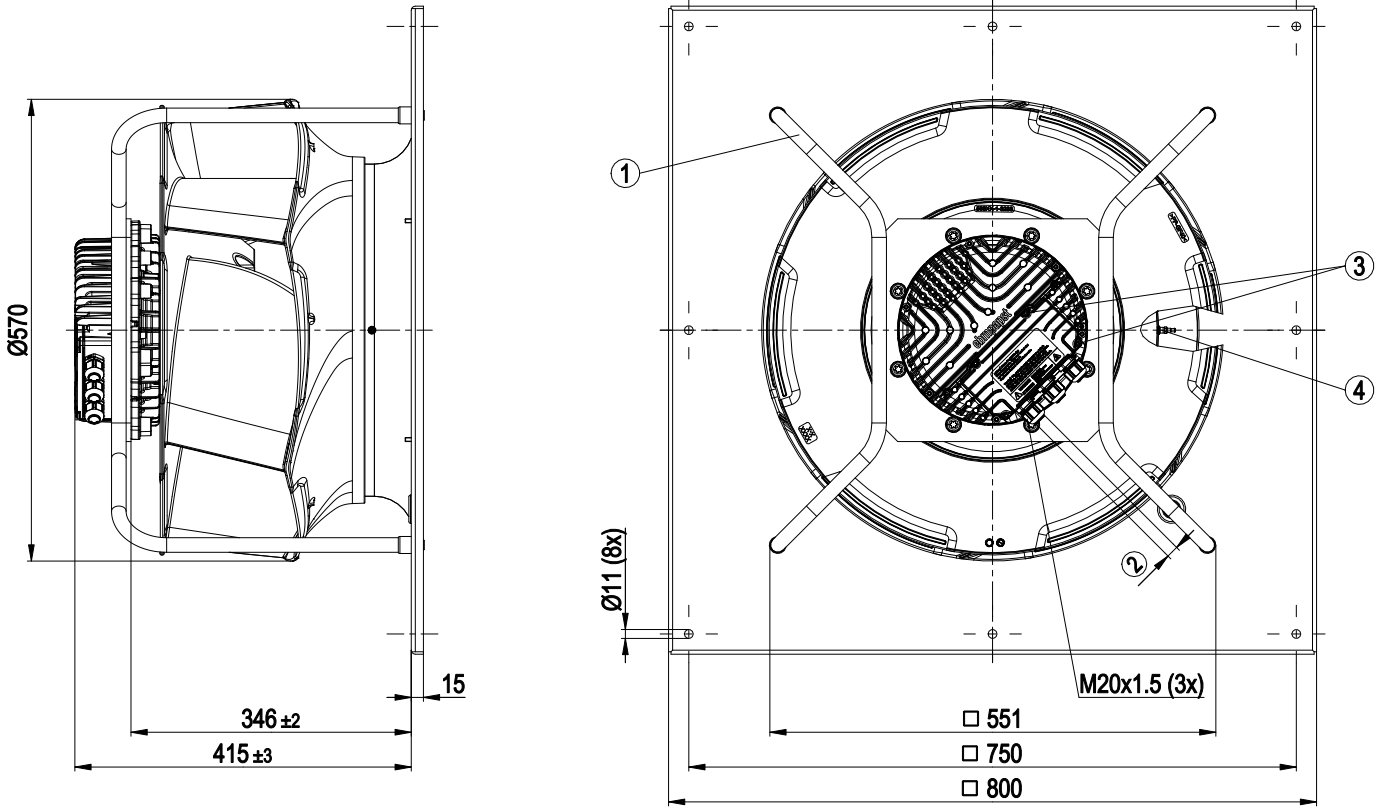

1	Installation position: Shaft horizontal (install the support struts only vertically as shown in the illustration!) or rotor on bottom
2	Cable diameter min. 4 mm, max. 10 mm, tightening torque 4 ± 0.6 Nm
3	Tightening torque 3.5 ± 0.5 Nm
4	Inlet nozzle with pressure tap (k-factor: 405)



EC centrifugal module - RadiCal

backward curved, single inlet
with support bracket

Connection screen

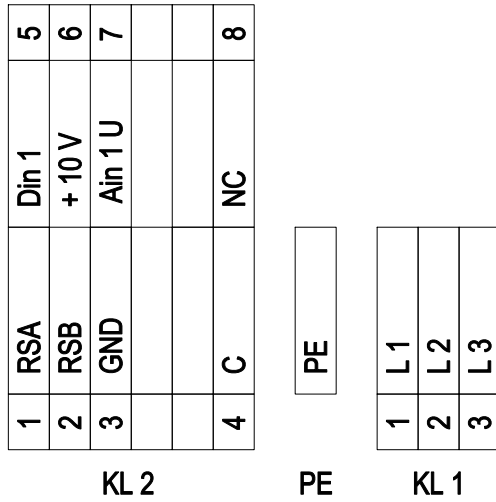

No.	Conn.	Designation	Function / assignment
KL 1	1	L1	Mains supply connection, supply voltage 3~380-480 VAC; 50/60 Hz
KL 1	2	L2	Mains supply connection, supply voltage 3~380-480 VAC; 50/60 Hz
KL 1	3	L3	Mains supply connection, supply voltage 3~380-480 VAC; 50/60 Hz
PE		PE	Earth connection, PE connection
KL 2	1	RSA	Bus connection RS-485, RSA, MODBUS RTU; SELV
KL 2	2	RSB	Bus connection RS-485, RSB, MODBUS RTU; SELV
KL 2	3	GND	Signal ground for control interface; SELV
KL2	4	C	Status relay; floating status contact; break for failure; contact rating 250 VAC / max. 2 A (AC1) / min. 10 mA
KL 2	5	Din1	Digital input 1 enabling of electronics, enabling: open pin or applied voltage 5-50 VDC disabling: bridge to GND or applied voltage <1 VDC reset function: triggers software reset after a level change to <1 V; SELV
KL 2	6	+ 10 V	Fixed voltage output 10 VDC; +10 V -3 %, max. 10 mA, short-circuit-proof, power supply for external devices (e.g. potentiometer); SELV Alternative: +24 VDC input for parametrisation via MODBUS without mains power
KL 2	7	Ain1 U	Analogue input 1 (set value) 0-10 V, Ri=100 kΩ, parametrisable curve; SELV
KL2	8	NC	Status relay, floating status contact; break for failure



Charts: Air flow 50 Hz

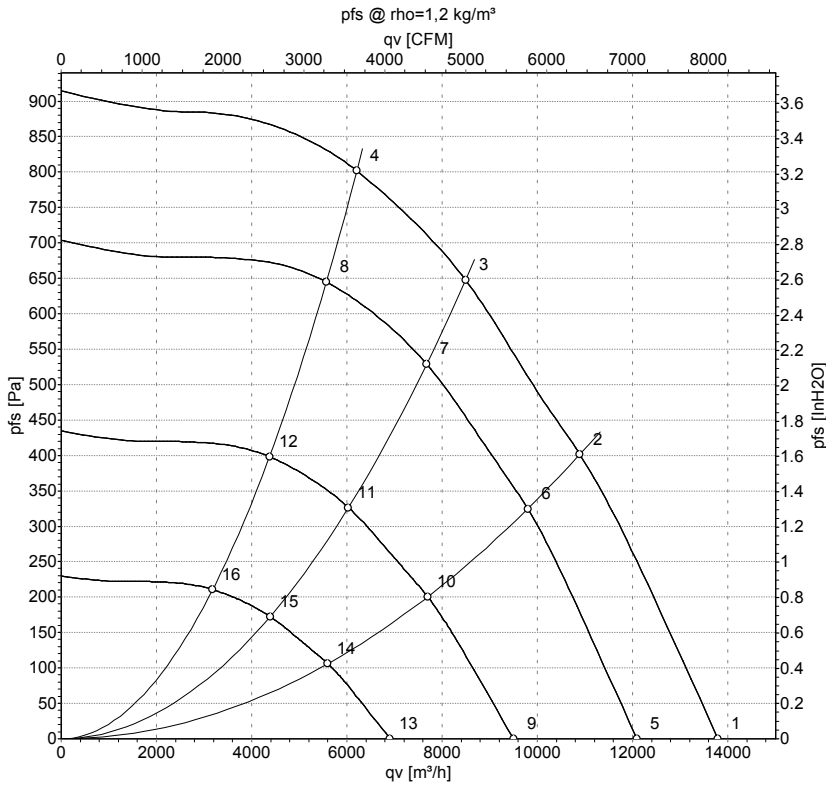

Measurement: LU-148925-1

Air performance measured as per ISO 5801 Installation category A. For detailed information on the measuring set-up, please contact ebmpapst. Suction-side noise levels: LwA measured as per ISO 13347 / LpA measured with 1m distance to fan axis. The values given are valid under the measuring conditions mentioned above and may vary according to the actual installation situation. With any deviation from the standard set-up, the specific values have to be checked and reviewed with the unit installed.

Measured values

	U	f	n	P _{ed}	I	LpA _{in}	LwA _{in}	LwA _{out}	q _v	P _{fs}	q _v	P _{fs}
	V	Hz	min ⁻¹	W	A	dB(A)	dB(A)	dB(A)	m ³ /h	Pa	cfm	in. wg
1	400	50	1540	1840	2.89	79	86	90	13785	0	8110	0.00
2	400	50	1540	2296	3.56	74	81	85	10890	400	6410	1.61
3	400	50	1540	2360	3.65	71	78	82	8490	650	5000	2.61
4	400	50	1540	2313	3.58	72	80	83	6205	800	3655	3.21
5	400	50	1400	1240	1.95	75	83	87	12085	0	7110	0.00
6	400	50	1400	1672	2.59	71	78	82	9795	327	5765	1.31
7	400	50	1400	1736	2.69	69	76	80	7675	533	4515	2.14
8	400	50	1400	1669	2.58	69	77	81	5565	645	3275	2.59
9	400	50	1100	601	0.94	69	77	81	9495	0	5590	0.00
10	400	50	1100	811	1.26	65	72	76	7695	202	4530	0.81
11	400	50	1100	842	1.30	63	70	74	6030	329	3550	1.32
12	400	50	1100	810	1.25	63	71	75	4375	398	2575	1.60
13	400	50	800	231	0.36	61	69	73	6905	0	4065	0.00
14	400	50	800	312	0.48	57	64	68	5595	107	3295	0.43
15	400	50	800	324	0.50	55	62	66	4385	174	2580	0.70
16	400	50	800	311	0.48	55	63	67	3180	211	1870	0.85

U = Supply voltage · f = Frequency · n = Speed (rpm) · P_{ed} = Power input · I = Current draw · LpA_{in} = Sound pressure level inlet side · LwA_{in} = Sound power level inlet side · LwA_{out} = Sound power level outlet side
 q_v = Air flow · p_{fs} = Pressure increase

