

backward curved, single inlet

with support bracket

K3G560-PC04-31 ebmpapst Datasheet

sales@fansco.com

www.fansco.com

Limited partnership · Headquarters Mulfingen  
County court Stuttgart · HRA 590344General partner Elektrobau Mulfingen GmbH · Headquarters Mulfingen  
County court Stuttgart · HRB 590142

## Nominal data

Type	K3G560-PC04-31	
Motor	M3G150-NA	
Phase		3~
Nominal voltage	VAC	400
Nominal voltage range	VAC	380 .. 480
Frequency	Hz	50/60
Type of data definition		ml
Speed (rpm)	min <sup>-1</sup>	1760
Power input	W	5000
Current draw	A	7.7
Min. ambient temperature	°C	-25
Max. ambient temperature	°C	50

ml = Max. load · me = Max. efficiency · fa = Running at free air · cs = Customer specs · cu = Customer unit  
Subject to alterations

## Data in accordance with ecodesign regulation EU 327/2011

		Actual	Request 2015			
01 Overall efficiency $\eta_{es}$	%	70.2	58.9	09 Power input $P_{ed}$	kW	5.03
02 Measurement category		A		09 Air flow $q_v$	m <sup>3</sup> /h	11760
03 Efficiency category		Static		09 Pressure increase $p_{fs}$	Pa	1035
04 Efficiency grade N		73.3	62	10 Speed (rpm) n	min <sup>-1</sup>	1770
05 Variable speed drive		Yes		11 Specific ratio*		1.01

Data definition with optimum efficiency.

\* Specific ratio =  $1 + p_{fs} / 100\,000\text{ Pa}$ 

LU-173565

The indicated efficiency values for obtaining conformity with the Ecodesign Directive EU 327/2011 were achieved with defined air conduction components (e.g. inlet nozzles).  
The dimensions are to be requested from ebm-papst. If other air guide geometries are used on the installation side, the ebm-papst evaluation loses its validity/conformity must be confirmed again.  
The product does not fall within the scope of Regulation (EU) 2019/1781 due to the exception specified in Article 2(2a) (motors completely integrated into a product).



backward curved, single inlet  
with support bracket

### Technical features

Mass	64.3 kg
Size	560 mm
Motor size	150
Surface of rotor	Coated in black
Material of electronics housing	Die-cast aluminium, coated in black
Material of impeller	Aluminium sheet, coated in black
Material of mounting plate	Sheet steel, galvanised and coated in black
Material of support bracket	Steel, galvanised and coated in black
Material of inlet nozzle	Sheet steel, galvanised and coated in black
Number of blades	5
Direction of rotation	Clockwise, seen on rotor
Type of protection	IP55
Insulation class	"F"
Humidity (F) / environmental protection class (H)	H2+S
Max. permissible ambient motor temp. (transp./ storage)	+80 °C
Min. permissible ambient motor temp. (transp./storage)	-40 °C
Mounting position	See key to the product drawing
Condensation drainage holes	Rotor-side
Operation mode	S1
Motor bearing	Ball bearing
Technical features	<ul style="list-style-type: none"> <li>- Output 10 VDC, max. 10 mA</li> <li>- Output 20 VDC, max. 50 mA</li> <li>- Output for slave 0-10 V</li> <li>- Operation and alarm display</li> <li>- Input for sensor 0-10 V or 4-20 mA</li> <li>- External 24 V input (programming)</li> <li>- External release input</li> <li>- Alarm relay</li> <li>- Integrated PID controller</li> <li>- Output limit</li> <li>- Motor current limit</li> <li>- PFC, passive</li> <li>- RS485 MODBUS RTU</li> <li>- Soft start</li> <li>- Control input 0-10 VDC / PWM</li> <li>- Control interface with SELV potential safely disconnected from the mains</li> <li>- Over-temperature protected electronics / motor</li> <li>- Line undervoltage / phase failure detection</li> </ul>
Touch current acc. IEC 60990 (measuring network Fig. 4, TN system)	<= 3.5 mA
Electrical connection	Terminal box
Motor protection	Reverse polarity and locked-rotor protection



# EC centrifugal module - RadiPac

backward curved, single inlet  
with support bracket

<b>Safety classification</b>	I; If a protective earth is connected by the customer This component to be built-in can have several local protection class ratings. The specification refers to the basic design of this component. The final protection class is based on the intended installation and connection of the component.
<b>Product conforming to standard</b>	EN 61800-5-1; CE
<b>Approval</b>	CSA C22.2 no. 77 + CAN/CSA-E60730-1; EAC; UL 1004-7 + 60730-1



# EC centrifugal module - RadiPac

backward curved, single inlet  
with support bracket

## Product drawing

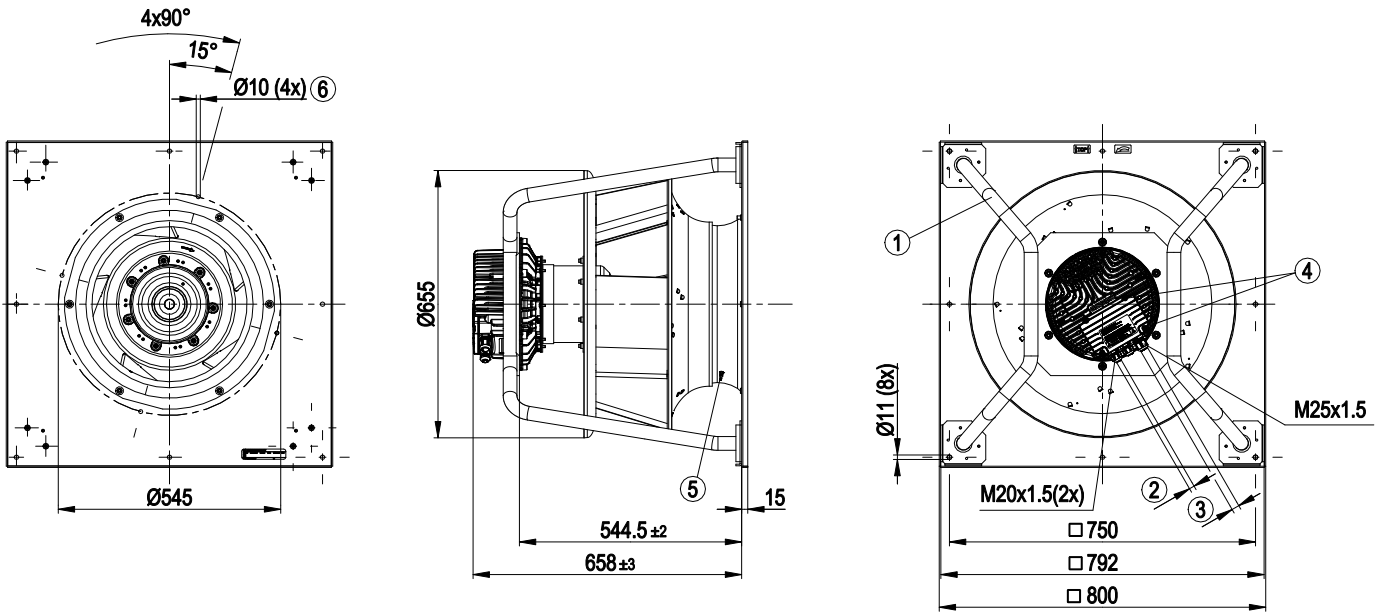

1	Installation position: Shaft horizontal (install the support struts only vertically as shown in the illustration!) or rotor on bottom; rotor on top on request
2	Cable diameter min. 4 mm, max. 10 mm, tightening torque 4±0.6 Nm
3	Cable diameter min. 9 mm, max. 16 mm, tightening torque 6±0.9 Nm
4	Tightening torque 3.5±0.5 Nm
5	Inlet nozzle with pressure tap (k-factor: 348)
6	Mounting holes for FlowGrid



backward curved, single inlet  
with support bracket

## Connection screen

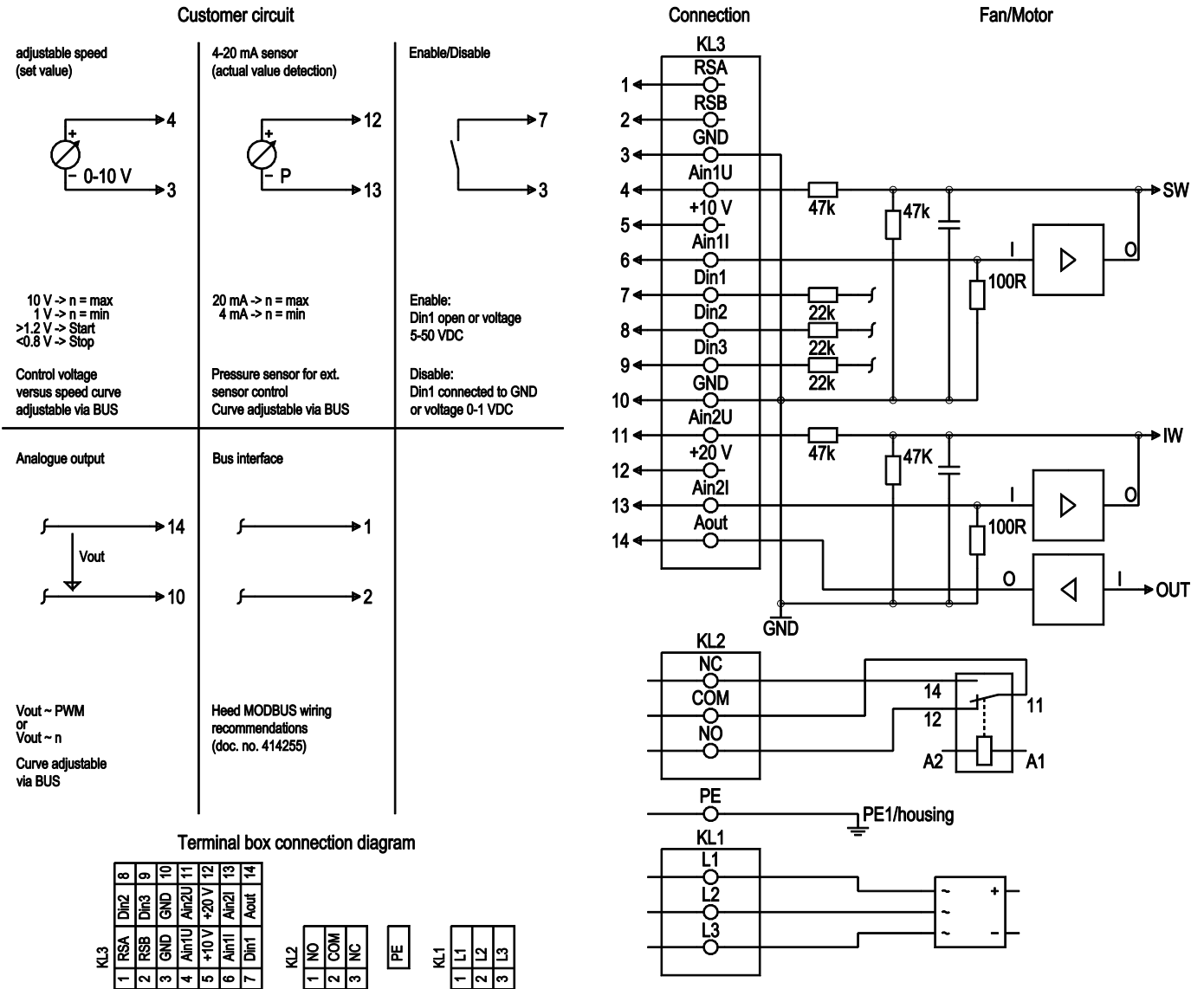

No.	Conn.	Designation	Function / assignment
KL 1	1	L1	Mains connection, power supply, phase, see type plate for voltage range
KL 1	2	L2	Mains connection, power supply, phase, see type plate for voltage range
KL 1	3	L3	Mains connection, power supply, phase, see type plate for voltage range
PE		PE	Earth connection, PE connection
KL 2	1	NO	Status relay, floating status contact, make for failure
KL 2	2	COM	Status relay, floating status contact, changeover contact, common connection, contact rating, max. 250 VAC/2 A (AC1)/min. 10 mA
KL 2	3	NC	Status relay, floating status contact, break for failure
KL 3	1	RSA	Bus connection RS485, RSA, MODBUS RTU; SELV
KL 3	2	RSB	Bus connection RS485, RSB, MODBUS RTU; SELV
KL 3	3 / 10	GND	Signal ground for control interface, SELV
KL 3	4	Ain1 U	Analogue input 1, set value: 0-10 V, Ri = 100 kΩ, parametrisable curve, only for use as alternative to input Ain1; SELV



# EC centrifugal module - RadiPac

backward curved, single inlet

with support bracket

No.	Conn.	Designation	Function / assignment
KL 3	5	+ 10 V	Fixed voltage output 10 VDC, +10 V +/-3 %, max. 10 mA, short-circuit-proof, power supply for ext. devices (e.g. potentiometer); SELV
KL 3	6	Ain1 I	Analogue input 1, set value: 4-20 mA; Ri = 100 Ω, parametrisable curve, only for use as alternative to input Ain1 U; SELV
KL 3	7	Din1	Digital input 1: Enabling of electronics, Enabling: Pin open or applied voltage 5-50 VDC Disabling: Bridge to GND or applied voltage <1 VDC Reset function: Triggers software reset after a level change to <1 VDC; SELV
KL 3	8	Din2	Digital input 2: Parameter set 1/2 switching, depending on EEPROM setting, the valid/used parameter set can be selected via the bus or via the digital input DIN2. Parameter set 1: Pin open or applied voltage 5-50 VDC Parameter set 2: bridge to GND or applied voltage <1 VDC; SELV
KL 3	9	Din3	Digital input 3: Controller function of integrated controller; depending on EEPROM setting, normal / inverse can be selected for the controller function of the integrated controller via the bus or the digital input Normal: Pin open or applied voltage 5-50 VDC Inverse: bridge to GND or applied voltage <1 VDC; SELV
KL 3	11	Ain2 U	Analogue input 2, actual value: 0-10 V, Ri = 100 kΩ, parametrisable curve, only usable as alternative to input Ain2; SELV
KL 3	12	+ 20 V	Fixed voltage output 20 VDC, +20 V +25/-10%, max. 50 mA, short-circuit-proof, power supply for ext. devices (e.g. sensors); SELV Alternatively: +24 VDC input for parametrisation without mains power
KL 3	13	Ain2 I	Analogue input 2, actual value: 4-20 mA, Ri = 100 Ω, parametrisable curve, only for use as alternative to input Ain2 U; SELV
KL 3	14	Aout	Analogue output 0-10 V, max. 5 mA, output of current motor level control coefficient; parametrisable curve; SELV



## Charts: Air flow 50 Hz

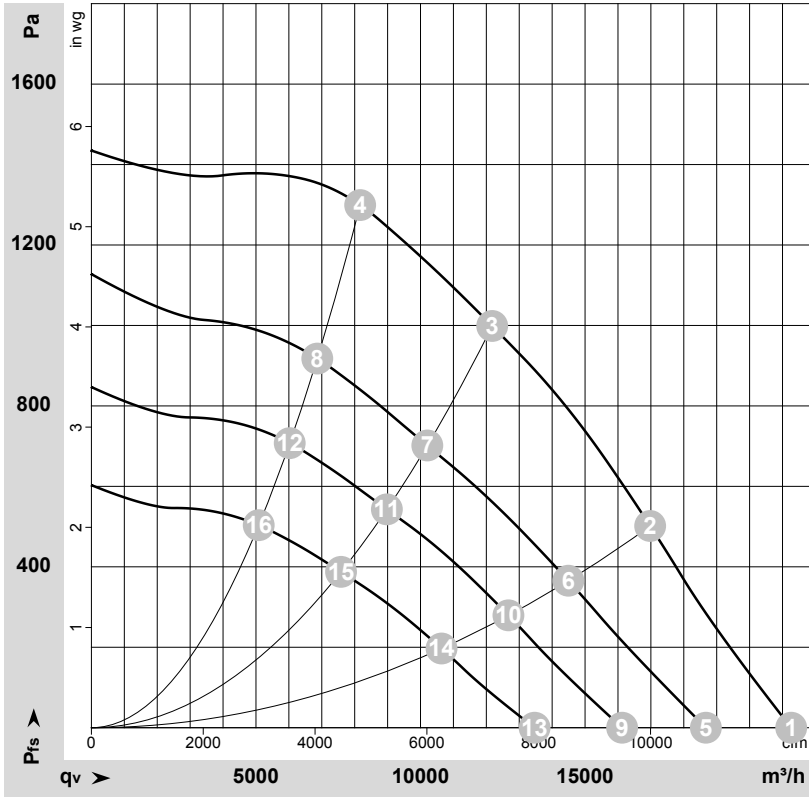

$\rho = 1.15 \text{ kg/m}^3 \pm 2 \%$

Measurement: LU-173565-1

Air performance measured as per ISO 5801 Installation category A. For detailed information on the measuring set-up, please contact ebmpapst. Suction-side noise levels: L<sub>wA</sub> measured as per ISO 13347 / L<sub>pA</sub> measured with 1m distance to fan axis. The values given are valid under the measuring conditions mentioned above and may vary according to the actual installation situation. With any deviation from the standard set-up, the specific values have to be checked and reviewed with the unit installed.

## Measured values

	U	f	n	P <sub>ed</sub>	I	L <sub>pA<sub>in</sub></sub>	L <sub>wA<sub>in</sub></sub>	L <sub>wA<sub>out</sub></sub>	q <sub>v</sub>	P <sub>fs</sub>	q <sub>v</sub>	P <sub>fs</sub>
	V	Hz	min <sup>-1</sup>	W	A	dB(A)	dB(A)	dB(A)	m <sup>3</sup> /h	Pa	cfm	in. wg
1	400	50	1760	2788	4.36	95	101	101	21265	0	12515	0.00
2	400	50	1760	4251	6.52	85	92	94	16980	500	9995	2.01
3	400	50	1760	5000	7.70	77	84	89	12180	1000	7170	4.01
4	400	50	1760	4788	7.32	80	87	92	8165	1300	4805	5.22
5	400	50	1575	1956	3.17	90	97	96	18670	0	10990	0.00
6	400	50	1510	2650	4.16	80	88	90	14495	368	8530	1.48
7	400	50	1480	2956	4.61	73	79	85	10205	701	6010	2.81
8	400	50	1490	2845	4.45	75	82	88	6865	920	4040	3.69
9	400	50	1365	1306	2.29	85	93	93	16125	0	9490	0.00
10	400	50	1325	1802	2.96	78	85	87	12670	281	7460	1.13
11	400	50	1305	2023	3.27	70	77	82	8980	543	5285	2.18
12	400	50	1310	1937	3.15	72	80	85	6025	709	3545	2.85
13	400	50	1145	827	1.58	81	89	90	13465	0	7925	0.00
14	400	50	1115	1113	2.04	73	80	83	10640	199	6260	0.80
15	400	50	1100	1271	2.25	65	72	77	7585	388	4465	1.56
16	400	50	1105	1212	2.17	67	74	79	5085	505	2990	2.03

U = Supply voltage · f = Frequency · n = Speed (rpm) · P<sub>ed</sub> = Power input · I = Current draw · L<sub>pA<sub>in</sub></sub> = Sound pressure level inlet side · L<sub>wA<sub>in</sub></sub> = Sound power level inlet side · L<sub>wA<sub>out</sub></sub> = Sound power level outlet side  
q<sub>v</sub> = Air flow · P<sub>fs</sub> = Pressure increase

