

backward curved, single inlet

with support bracket

K3G560-PB31-B1 ebmpapst Datasheet

sales@fansco.com

www.fansco.com

Limited partnership · Headquarters Muldingen
County court Stuttgart · HRA 590344

General partner Elektrobau Muldingen GmbH · Headquarters Muldingen
County court Stuttgart · HRB 590142

Nominal data

| | | |
|--------------------------|-------------------|------------|
| Type | K3G560-PB31-B1 | |
| Motor | M3G150-IF | |
| Phase | | 3~ |
| Nominal voltage | VAC | 400 |
| Nominal voltage range | VAC | 380 .. 480 |
| Frequency | Hz | 50/60 |
| Type of data definition | | ml |
| Speed (rpm) | min ⁻¹ | 1540 |
| Power input | W | 3300 |
| Current draw | A | 5.1 |
| Min. ambient temperature | °C | -25 |
| Max. ambient temperature | °C | 50 |

ml = Max. load · me = Max. efficiency · fa = Running at free air · cs = Customer specs · cu = Customer unit
Subject to alterations

Data in accordance with ecodesign regulation EU 327/2011 (EN 17166)

| | | Actual | Request 2015 | | | |
|-----------------------------------|---|--------|--------------|-------------------------------|-------------------|-------|
| 01 Overall efficiency η_{es} | % | 71 | 56.9 | 09 Power input P_{ed} | kW | 3.29 |
| 02 Measurement category | | A | | 09 Air flow q_v | m ³ /h | 10515 |
| 03 Efficiency category | | Static | | 09 Pressure increase p_{fs} | Pa | 759 |
| 04 Efficiency grade N | | 76.1 | 62 | 10 Speed (rpm) n | min ⁻¹ | 1535 |
| 05 Variable speed drive | | Yes | | 11 Specific ratio* | | 1.01 |

Data definition with optimum efficiency.

The ErP data is determined using a motor-impeller combination in a standardised measurement configuration.

* Specific ratio = $1 + p_{fs} / 100\,000\text{ Pa}$

LU-173841



backward curved, single inlet
with support bracket

Technical features

| | |
|--|---|
| Mass | 50 kg |
| Size | 560 mm |
| Motor size | 150 |
| Surface of rotor | Coated in black |
| Material of electronics housing | Die-cast aluminium, coated in black |
| Material of impeller | Aluminium sheet, coated in black |
| Material of mounting plate | Sheet steel, galvanised and coated in black |
| Material of support bracket | Steel, galvanised and coated in black |
| Material of inlet nozzle | Sheet steel, galvanised and coated in black |
| Number of blades | 5 |
| Direction of rotation | Clockwise, seen on rotor |
| Type of protection | IP55 |
| Insulation class | "F" |
| Humidity (F) / environmental protection class (H) | H2+S |
| Max. permissible ambient motor temp. (transp./ storage) | +80 °C |
| Min. permissible ambient motor temp. (transp./storage) | -40 °C |
| Mounting position | Refer to product drawing |
| Condensation drainage holes | Rotor-side |
| Operation mode | S1 |
| Motor bearing | Ball bearing |
| Technical features | <ul style="list-style-type: none"> - Output 10 VDC, max. 10 mA - Operation and alarm display - External 24 V input (programming) - External release input - Alarm relay - Integrated PID controller - Motor current limit - PFC, passive - RS485 MODBUS RTU - Soft start - Control input 0-10 VDC / PWM - Control interface with SELV potential safely disconnected from the mains - Over-temperature protected electronics / motor - Line undervoltage / phase failure detection |
| EMC interference immunity | Acc. to EN 61000-6-2 (industrial environment) |
| EMC interference emission | Acc. to EN 61000-6-3 (household environment), except EN 61000-3-2 for professionally used devices with a total rated power greater than 1 kW |
| Touch current acc. IEC 60990 (measuring network Fig. 4, TN system) | <= 3.5 mA |
| Electrical connection | Terminal box |
| Motor protection | Reverse polarity and locked-rotor protection |
| Protection class | I (if protective earth is connected by customer) |
| Product conforming to standard | EN 61800-5-1; CE |
| Approval | EAC |

EC centrifugal module - RadiPac

backward curved, single inlet
with support bracket

Product drawing

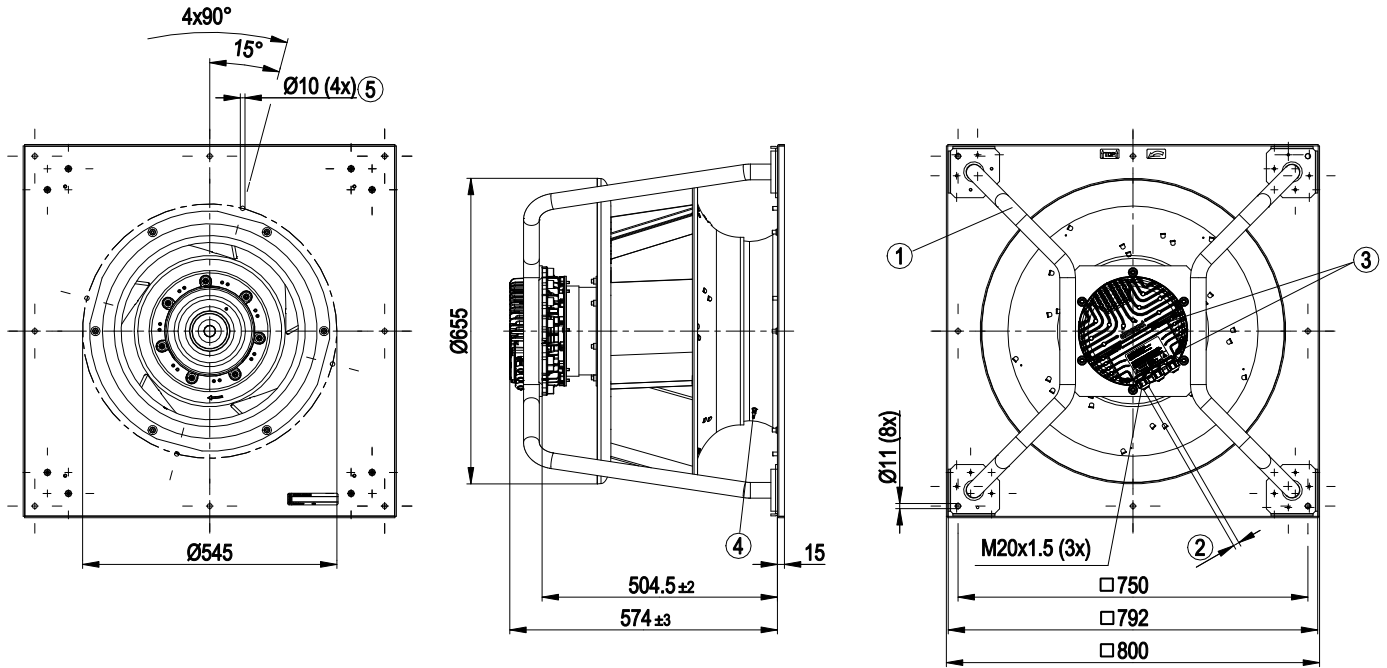

| | |
|---|--|
| 1 | Installation position: Shaft horizontal (install the support struts only vertically as shown in the illustration!) or rotor on bottom; rotor on top on request |
| 2 | Cable diameter min. 4 mm, max. 10 mm, tightening torque 4±0.6 Nm |
| 3 | Tightening torque 3.5±0.5 Nm |
| 4 | Inlet nozzle with pressure tap (k-factor: 348) |
| 5 | Mounting holes for FlowGrid |



EC centrifugal module - RadiPac

backward curved, single inlet
with support bracket

Connection screen

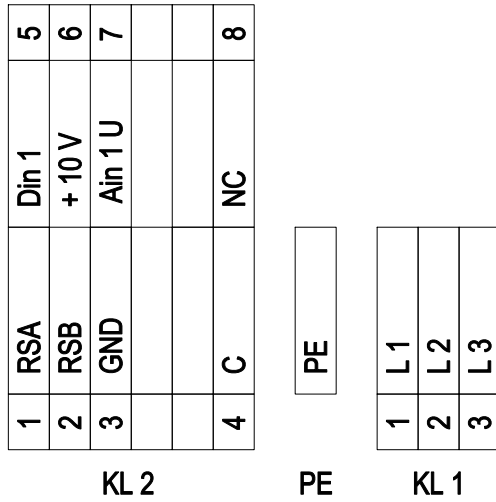

| No. | Conn. | Designation | Function / assignment |
|------|-------|-------------|--|
| KL 1 | 1 | L1 | Mains supply connection, supply voltage 3~380-480 VAC; 50/60 Hz |
| KL 1 | 2 | L2 | Mains supply connection, supply voltage 3~380-480 VAC; 50/60 Hz |
| KL 1 | 3 | L3 | Mains supply connection, supply voltage 3~380-480 VAC; 50/60 Hz |
| PE | | PE | Earth connection, PE connection |
| KL 2 | 1 | RSA | Bus connection RS-485, RSA, MODBUS RTU; SELV |
| KL 2 | 2 | RSB | Bus connection RS-485, RSB, MODBUS RTU; SELV |
| KL 2 | 3 | GND | Signal ground for control interface; SELV |
| KL2 | 4 | C | Status relay; floating status contact; break for failure; contact rating 250 VAC / max. 2 A (AC1) / min. 10 mA |
| KL 2 | 5 | Din1 | Digital input 1 enabling of electronics, enabling: open pin or applied voltage 5-50 VDC disabling: bridge to GND or applied voltage <1 VDC reset function: triggers software reset after a level change to <1 V; SELV |
| KL 2 | 6 | + 10 V | Fixed voltage output 10 VDC; +10 V -3 %, max. 10 mA, short-circuit-proof, power supply for external devices (e.g. potentiometer); SELV Alternative: +24 VDC input for parametrisation via MODBUS without mains power |
| KL 2 | 7 | Ain1 U | Analogue input 1 (set value) 0-10 V, Ri=100 kΩ, parametrisable curve; SELV |
| KL2 | 8 | NC | Status relay, floating status contact; break for failure |



Charts: Air flow 50 Hz

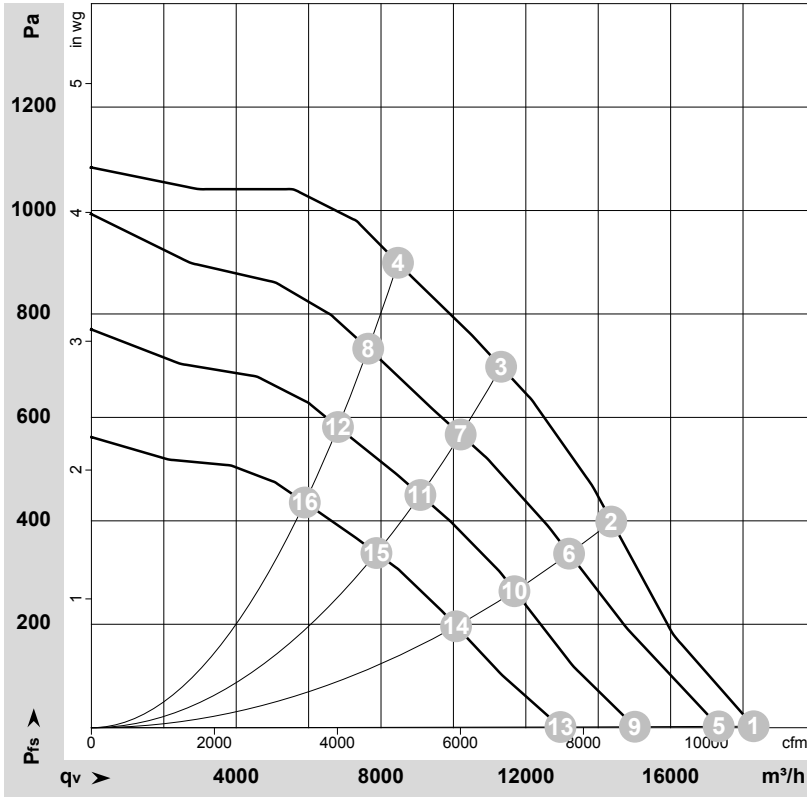

$\rho = 1.15 \text{ kg/m}^3 \pm 2 \%$

Measurement: LU-173841-1

Air performance measured as per ISO 5801 Installation category A. For detailed information on the measuring set-up, please contact ebmpapst. Suction-side noise levels: LwA measured as per ISO 13347 / LpA measured with 1m distance to fan axis. The values given are valid under the measuring conditions mentioned above and may vary according to the actual installation situation. With any deviation from the standard set-up, the specific values have to be checked and reviewed with the unit installed.

Measured values

| | U | f | n | P _{ed} | I | LpA _{in} | LwA _{in} | LwA _{out} | q _v | P _{fs} | q _v | P _{fs} |
|----|-----|----|-------------------|-----------------|------|-------------------|-------------------|--------------------|-------------------|-----------------|----------------|-----------------|
| | V | Hz | min ⁻¹ | W | A | dB(A) | dB(A) | dB(A) | m ³ /h | Pa | cfm | in. wg |
| 1 | 400 | 50 | 1540 | 1834 | 2.88 | 91 | 97 | 97 | 18290 | 0 | 10765 | 0.00 |
| 2 | 400 | 50 | 1540 | 2810 | 4.32 | 81 | 88 | 90 | 14360 | 400 | 8450 | 1.61 |
| 3 | 400 | 50 | 1540 | 3300 | 5.10 | 76 | 82 | 86 | 11320 | 700 | 6665 | 2.81 |
| 4 | 400 | 50 | 1540 | 3230 | 4.95 | 76 | 82 | 86 | 8470 | 900 | 4985 | 3.61 |
| 5 | 400 | 50 | 1470 | 1591 | 2.52 | 89 | 96 | 95 | 17325 | 0 | 10200 | 0.00 |
| 6 | 400 | 50 | 1410 | 2168 | 3.37 | 80 | 86 | 88 | 13195 | 337 | 7765 | 1.35 |
| 7 | 400 | 50 | 1385 | 2389 | 3.70 | 71 | 79 | 82 | 10200 | 567 | 6005 | 2.28 |
| 8 | 400 | 50 | 1385 | 2372 | 3.68 | 71 | 78 | 82 | 7645 | 733 | 4500 | 2.94 |
| 9 | 400 | 50 | 1275 | 1059 | 1.77 | 86 | 93 | 93 | 15015 | 0 | 8835 | 0.00 |
| 10 | 400 | 50 | 1250 | 1524 | 2.43 | 75 | 83 | 85 | 11685 | 265 | 6880 | 1.06 |
| 11 | 400 | 50 | 1235 | 1699 | 2.69 | 69 | 75 | 80 | 9085 | 450 | 5350 | 1.81 |
| 12 | 400 | 50 | 1235 | 1684 | 2.66 | 69 | 75 | 80 | 6810 | 581 | 4010 | 2.33 |
| 13 | 400 | 50 | 1110 | 714 | 1.31 | 82 | 89 | 90 | 12955 | 0 | 7625 | 0.00 |
| 14 | 400 | 50 | 1080 | 1001 | 1.69 | 72 | 79 | 82 | 10075 | 196 | 5930 | 0.79 |
| 15 | 400 | 50 | 1070 | 1116 | 1.85 | 65 | 72 | 77 | 7875 | 338 | 4635 | 1.36 |
| 16 | 400 | 50 | 1070 | 1101 | 1.83 | 65 | 72 | 77 | 5895 | 436 | 3470 | 1.75 |

U = Supply voltage · f = Frequency · n = Speed (rpm) · P_{ed} = Power input · I = Current draw · LpA_{in} = Sound pressure level inlet side · LwA_{in} = Sound power level inlet side · LwA_{out} = Sound power level outlet side
q_v = Air flow · P_{fs} = Pressure increase

