

backward curved, single inlet

with support bracket

K3G560-AQ04-69 ebmpapst Datasheet

sales@fansco.com

www.fansco.com

Limited partnership · Headquarters Mulfingen
County court Stuttgart · HRA 590344General partner Elektrobau Mulfingen GmbH · Headquarters Mulfingen
County court Stuttgart · HRB 590142

Nominal data

Type	K3G560-AQ04-69	
Motor	M3G150-NA	
Phase		3~
Nominal voltage	VAC	400
Nominal voltage range	VAC	380 .. 480
Frequency	Hz	50/60
Type of data definition		ml
Speed (rpm)	min ⁻¹	1750
Power input	W	4700
Current draw	A	7.3
Min. ambient temperature	°C	-25
Max. ambient temperature	°C	40

ml = Max. load · me = Max. efficiency · fa = Running at free air · cs = Customer specs · cu = Customer unit
Subject to alterations

Data according to ErP directive

		Actual	Request 2015			
01 Overall efficiency η_{es}	%	67.2	58.5	09 Power input P_{ed}	kW	4.67
02 Measurement category		A		09 Air flow q_v	m ³ /h	11640
03 Efficiency category		Static		09 Pressure increase p_{fs}	Pa	934
04 Efficiency grade N		70.7	62	10 Speed (rpm) n	min ⁻¹	1765
05 Variable speed drive		Yes		11 Specific ratio*		1.01

Data definition with optimum efficiency.

The ErP data is determined using a motor-impeller combination in a standardised measurement configuration.

* Specific ratio = $1 + p_{fs} / 100\,000\text{ Pa}$

LU-128639



backward curved, single inlet
with support bracket

Technical features

Mass	69.0 kg
Size	560 mm
Surface of rotor	Coated in black
Material of electronics housing	Die-cast aluminium
Material of impeller	Aluminium sheet
Material of mounting plate	Sheet steel, galvanised
Material of support bracket	Steel, coated in black
Material of inlet nozzle	Sheet steel, galvanised
Number of blades	7
Direction of rotation	Clockwise, seen on rotor
Type of protection	IP 55
Insulation class	"F"
Humidity (F)/environmental protection class (H)	H1
Max. permissible ambient motor temp. (transp./ storage)	+80 °C
Min. permissible ambient motor temp. (transp./storage)	-40 °C
Mounting position	Shaft horizontal or rotor on bottom; rotor on top on request
Condensate discharge holes	Rotor-side
Operation mode	S1
Motor bearing	Ball bearing
Technical features	<ul style="list-style-type: none"> - Output 10 VDC, max. 10 mA - External 24 V input (programming) - Alarm relay - Integrated PID controller - Output limit - Motor current limit - PFC, passive - RS485 MODBUS RTU - Soft start - Control input 0-10 VDC - Control interface with SELV potential safely disconnected from the mains - Over-temperature protected electronics / motor - Line undervoltage / phase failure detection
EMC interference immunity	Acc. to EN 61000-6-2 (industrial environment)
EMC interference emission	Acc. to EN 61000-6-4 (industrial environment)
Touch current acc. IEC 60990 (measuring network Fig. 4, TN system)	<= 3.5 mA
Electrical leads	Via terminal box
Motor protection	Reverse polarity and locked-rotor protection
Protection class	I (if protective earth is connected by customer)
Product conforming to standard	EN 61800-5-1; CE
Approval	C22.2 Nr.77 + CAN/CSA-E60730-1; EAC; UL 1004-7 + 60730



EC centrifugal module - RadiPac

backward curved, single inlet
with support bracket

Product drawing

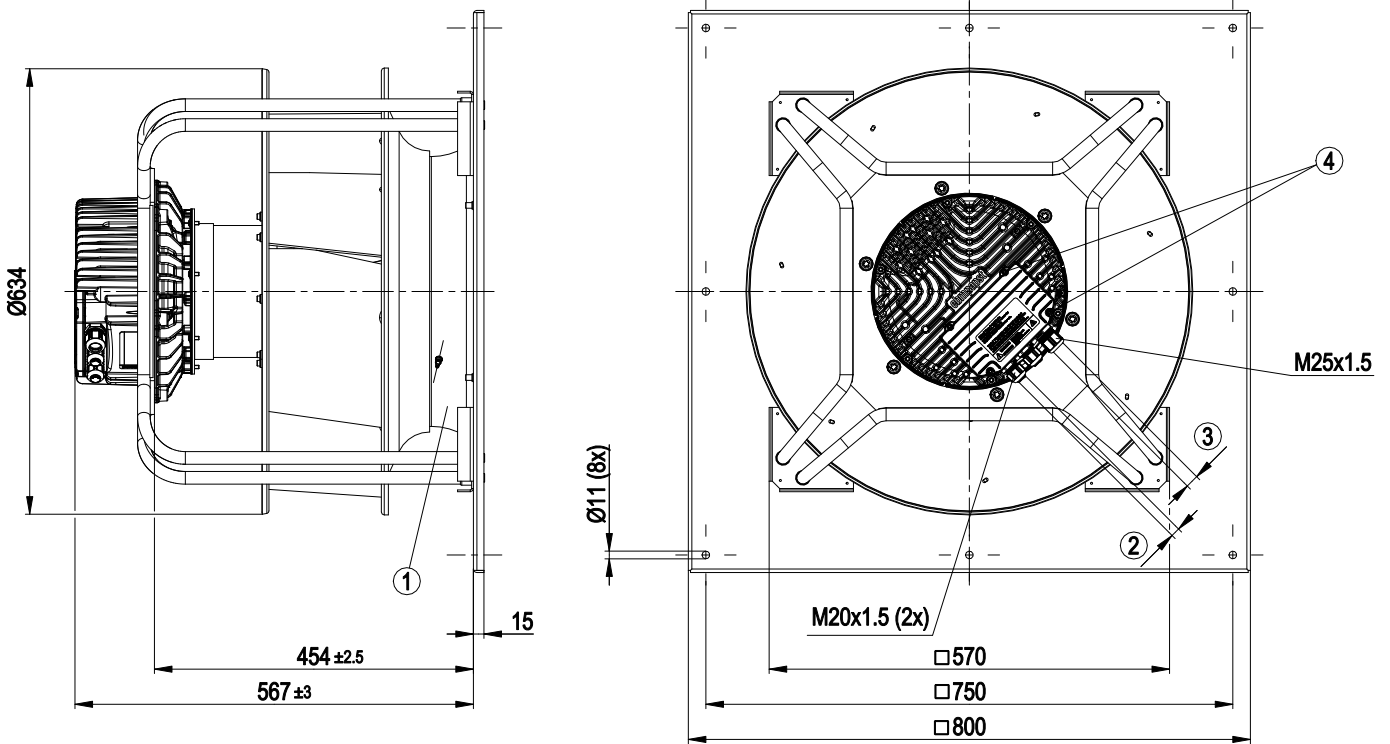

1	Inlet nozzle with pressure tap (k-factor: 348)
2	Cable diameter min. 4 mm, max. 10 mm, tightening torque 4±0.6 Nm
3	Cable diameter min. 9 mm, max. 16 mm, tightening torque 6±0.9 Nm
4	Tightening torque 3.5±0.5 Nm



EC centrifugal module - RadiPac

backward curved, single inlet
with support bracket

Connection screen

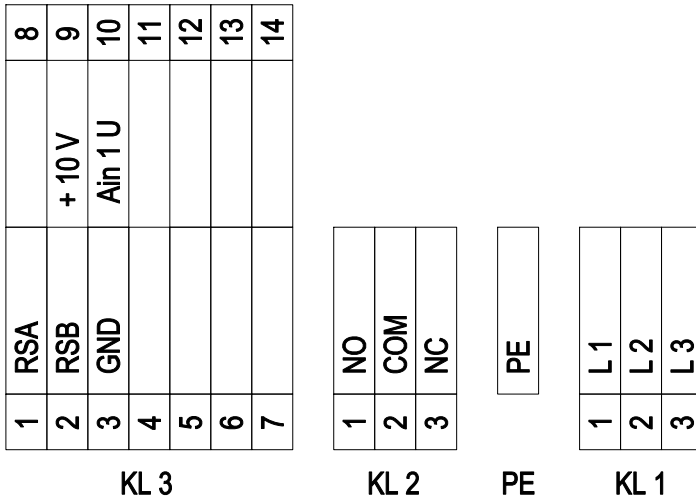

No.	Conn.	Designation	Function / assignment
1	1	L1	Mains supply connection, supply voltage 3-phase 380-480 VAC; 50/60 Hz
1	2	L2	Mains supply connection, supply voltage 3-phase 380-480 VAC; 50/60 Hz
1	3	L3	Mains supply connection, supply voltage 3-phase 380-480 VAC; 50/60 Hz
PE	-	PE	Protective earth connection
2	1	NO	Floating status contact, closes on error
2	2	COM	Floating status contact, changeover contact, common connection (2 A, max. 250 VAC, min. 10 mA, AC1)
2	3	NC	Floating status contact, break for failure
3	1	RSA	RS-485 interface for MODBUS, RSA; SELV
3	2	RSB	RS-485 interface for MODBUS, RSB; SELV
3	3	GND	Signal ground for control interface; SELV
3	4		not used
3	5		not used
3	6		not used
3	7		not used
3	8		not used
3	9	+10V	Voltage output 10 VDC (±3%), max. 10 mA, power supply for external devices (e.g. potentiometer); SELV
3	10	Ain1 U	Control input / current sensor value input 0-10 VDC, impedance 100 kΩ; SELV
3	11		not used
3	12		not used
3	13		not used
3	14		not used



Charts: Air flow 50 Hz

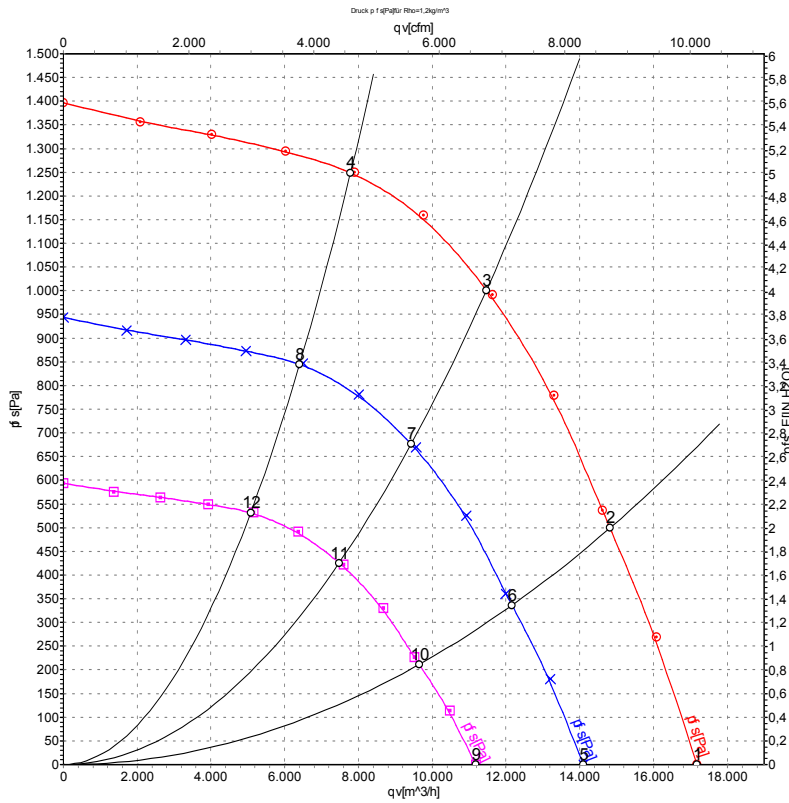

Measurement: LU-128639-1

Air performance measured as per ISO 5801 Installation category A. For detailed information on the measuring set-up, please contact ebmpapst. Suction-side noise levels: LwA measured as per ISO 13347 / LpA measured with 1m distance to fan axis. The values given are valid under the measuring conditions mentioned above and may vary according to the actual installation situation. With any deviation from the standard set-up, the specific values have to be checked and reviewed with the unit installed.

Measured values

	U	f	n	P _{ed}	I	LpA _{in}	LwA _{in}	LwA _{out}	q _v	P _{fs}	q _v	P _{fs}
	V	Hz	min ⁻¹	W	A	dB(A)	dB(A)	dB(A)	m ³ /h	Pa	cfm	inH ₂ O
1	400	50	1750	3032	4.77	88	97	103	17170	0	10105	0.00
2	400	50	1750	3929	6.10	84	91	96	14820	500	8725	2.01
3	400	50	1750	4700	7.30	78	84	91	11470	1000	6750	4.01
4	400	50	1750	4366	6.71	79	86	92	7785	1250	4585	5.02
5	400	50	1450	1675	2.64	84	93	98	14090	0	8295	0.00
6	400	50	1450	2171	3.37	80	87	92	12160	336	7155	1.35
7	400	50	1450	2602	4.01	74	80	86	9430	681	5550	2.73
8	400	50	1450	2432	3.74	75	82	88	6405	848	3770	3.40
9	400	50	1150	836	1.32	79	88	93	11180	0	6580	0.00
10	400	50	1150	1083	1.68	75	82	87	9650	211	5680	0.85
11	400	50	1150	1298	2.00	68	75	81	7480	428	4400	1.72
12	400	50	1150	1213	1.87	70	76	83	5080	534	2990	2.14

U = Supply voltage · f = Frequency · n = Speed (rpm) · P_{ed} = Power input · I = Current draw · LpA_{in} = Sound pressure level inlet side · LwA_{in} = Sound power level inlet side · LwA_{out} = Sound power level outlet side
q_v = Air flow · P_{fs} = Pressure increase

