

EC centrifugal module - Plug fan

forward curved, single inlet

with support bracket

K3G560-AQ04-33 ebmpapst Datasheet

sales@fansco.com

www.fansco.com

Limited partnership · Headquarters Muldingen
County court Stuttgart · HRA 590344

General partner Elektrobau Muldingen GmbH · Headquarters Muldingen
County court Stuttgart · HRB 590142



Nominal data

Type	K3G560-AQ04-33	
Motor	M3G150-NA	
Phase		3~
Nominal voltage	VAC	400
Nominal voltage range	VAC	380 .. 480
Frequency	Hz	50/60
Type of data definition		ml
Speed	min ⁻¹	1750
Power input	W	4700
Current draw	A	7.3
Min. ambient temperature	°C	-25
Max. ambient temperature	°C	40

ml = max. load · me = max. efficiency · fa = running at free air · cs = customer specs · cu = customer unit
Subject to alterations

Data according to ErP directive

Installation category	A
Efficiency category	Static
Variable speed drive	Yes
Specific ratio*	1.01

* Specific ratio = $1 + p_{fs} / 100\,000\text{ Pa}$

		Actual	Request 2013	Request 2015
Overall efficiency η_{es}		67.2	54.5	58.5
Efficiency grade N		70.7	58	62
Power input P_{ed}	kW	4.67		
Air flow q_v	m ³ /h	11640		
Pressure increase p_{fs}	Pa	934		
Speed n	min ⁻¹	1765		

Data established at point of optimum efficiency



Technical features

Mass	69 kg
Size	560 mm
Surface of rotor	Coated in black
Material of electronics housing	Die-cast aluminium, coated in black
Material of impeller	Aluminium sheet, coated in black
Material of mounting plate	Sheet steel, hot-galvanised and coated in black
Material of support bracket	Steel, galvanised and coated in black
Material of inlet nozzle	Sheet steel, hot-galvanised and coated in black
Number of blades	7
Direction of rotation	Clockwise, seen on rotor
Type of protection	IP 54
Insulation class	"F"
Humidity class	F4-2
Max. permissible ambient motor temp. (transp./ storage)	+80 °C
Min. permissible ambient motor temp. (transp./storage)	-40 °C
Mounting position	Shaft horizontal or rotor on bottom; rotor on top on request
Condensate discharge holes	Rotor-side
Operation mode	S1
Motor bearing	Ball bearing
Technical features	<ul style="list-style-type: none"> - PFC, passive - Control input 0-10 VDC / PWM - Output 10 VDC, max. 10 mA - Over-temperature protected electronics / motor - Alarm relay - Integrated PID controller - Input for sensor 0-10 V or 4-20 mA - Output for slave 0-10 V - RS485 ebmBUS - Motor current limit - Soft start - Line undervoltage / phase failure detection - Output 20 VDC, max. 50 mA
EMC interference immunity	Acc. to EN 61000-6-2 (industrial environment)
EMC interference emission	Acc. to EN 61000-6-3 (household environment)
Touch current acc. IEC 60990 (measuring network Fig. 4, TN system)	<= 3.5 mA
Electrical leads	Via terminal box
Motor protection	Reverse polarity and locked-rotor protection
Protection class	I (if protective earth is connected by customer)
Product conforming to standard	EN 61800-5-1; CE

EC centrifugal module - Plug fan

forward curved, single inlet
with support bracket

Product drawing

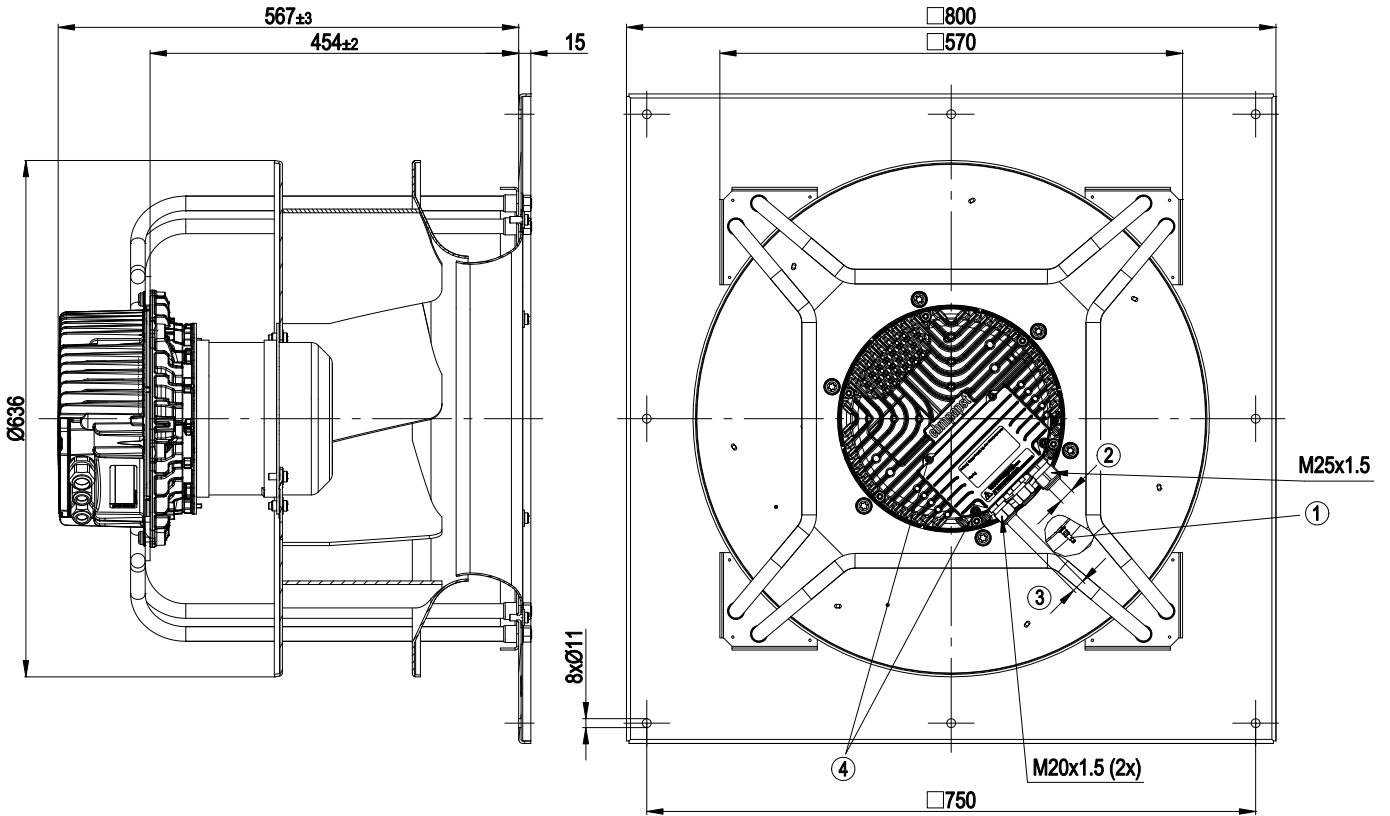

- | | |
|---|---|
| 1 | Inlet nozzle with bleeder connection for pressure relief (k-factor 348) |
| 2 | Cable diameter: min. 9 mm, max. 16 mm; tightening torque: 6±0.9 Nm |
| 3 | Cable diameter: min. 4 mm, max. 10 mm; tightening torque: 4±0.6 Nm |
| 4 | Tightening torque 3.5±0.5 Nm |



EC centrifugal module - Plug fan

forward curved, single inlet

with support bracket

Charts: Air flow 50 Hz

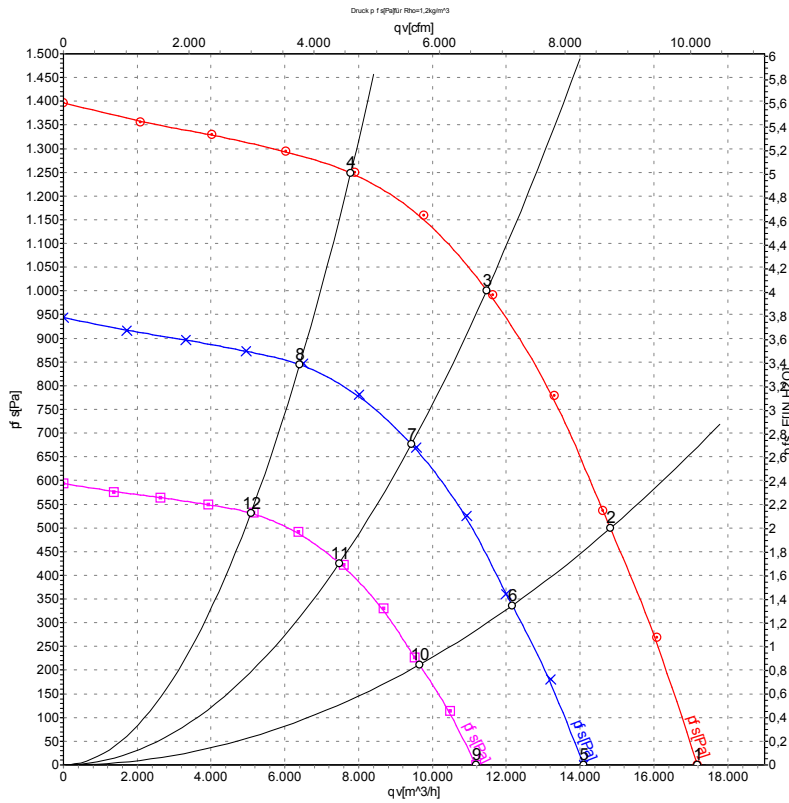

Measurement: LU-128639

Air performance measured as per ISO 5801 Installation category A. For detailed information on the measuring set-up, please contact ebmpapst. Suction-side noise levels: LwA measured as per ISO 13347 / LpA measured with 1m distance to fan axis. The values given are valid under the measuring conditions mentioned above and may vary according to the actual installation situation. With any deviation from the standard set-up, the specific values have to be checked and reviewed with the unit installed.

Measured values

	U	f	n	P _{ed}	I	LpA _{in}	LwA _{in}	LwA _{out}	qv	p _{fs}
	V	Hz	min ⁻¹	W	A	dB(A)	dB(A)	dB(A)	m ³ /h	Pa
1	400	50	1750	3032	4.77	88	97	103	17170	0
2	400	50	1750	3929	6.10	84	91	96	14820	500
3	400	50	1750	4700	7.30	78	84	91	11470	1000
4	400	50	1750	4366	6.71	79	86	92	7785	1250
5	400	50	1450	1675	2.64	84	93	98	14090	0
6	400	50	1450	2171	3.37	80	87	92	12160	336
7	400	50	1450	2602	4.01	74	80	86	9430	681
8	400	50	1450	2432	3.74	75	82	88	6405	848
9	400	50	1150	836	1.32	79	88	93	11180	0
10	400	50	1150	1083	1.68	75	82	87	9650	211
11	400	50	1150	1298	2.00	68	75	81	7480	428
12	400	50	1150	1213	1.87	70	76	83	5080	534

U = Supply voltage · f = Frequency · n = Speed · P_{ed} = Power input · I = Current draw · LpA_{in} = Sound pressure level inlet side · LwA_{in} = Sound power level inlet side · LwA_{out} = Sound power level outlet side
 qv = Air flow · p_{fs} = Pressure increase

