

K3G560-AQ04-01

EC centrifugal module - Plug fan

backward curved, single inlet

with support bracket

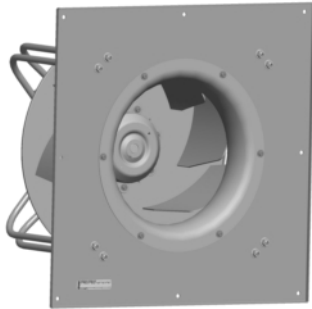

K3G560-AQ04-01 ebmpapst Datasheet

sales@fansco.com

www.fansco.com

Nominal data

Type	K3G560-AQ04-01	
Motor	M3G150-NA	
Phase		3~
Nominal voltage	[VAC]	400
Nominal voltage range	[VAC]	380 .. 480
Frequency	[Hz]	50/60
Type of data definition		ml
Speed	[min ⁻¹]	1750
Power input	[W]	4700
Current draw	[A]	7.3
Min. ambient temperature	[°C]	-25
Max. ambient temperature	[°C]	40

ml = max. load · me = max. efficiency · rfa = running at free air · cs = customer specs · cu = customer unit
Subject to alterations

Technical features

Leakage current	<= 3.5 mA
Size	560 mm
Operation mode	S1
Direction of rotation	Clockwise, seen on rotor
Mounting position	Shaft horizontal or rotor on bottom
Electrical leads	Via terminal box
EMC interference emission	Acc. to EN 61000-6-3 (household environment)
EMC interference immunity	Acc. to EN 61000-6-2 (industrial environment)
Humidity class	F4-1
Insulation class	"F"
Condensate discharge holes	Rotor-side
Bearing motor	Ball bearing
Mass	69 kg
Material of inlet nozzle	Sheet steel, hot-galvanised
Material of electronics housing	Die-cast aluminium
Material of impeller	Aluminium sheet
Material of mounting plate	Sheet steel, hot-galvanised
Material of support bracket	Steel, coated in black
Motor protection	Reverse polarity and locked-rotor protection
Product conforming to standard	CE; EN 61800-5-1
Surface of rotor	Coated in black
Number of blades	7
Type of protection	IP 54
Protection class	I
Technical features	<ul style="list-style-type: none"> - Output 10 VDC, max. 10 mA - Output 20 VDC, max. 50 mA - Output for slave 0-10 V - Input for sensor 0-10 V or 4-20 mA - External 24 V input (programming) - Alarm relay - Integrated PID controller - Motor current limit - PFC, passive - RS485 MODBUS RTU - Soft start - Control input 0-10 VDC / PWM - Over-temperature protected electronics / motor - Line undervoltage / phase failure detection
Max. permissible ambient motor temp. (transp./ storage)	+80 °C
Min. permissible ambient motor temp. (transp./storage)	-40 °C

EC centrifugal module - Plug fan

backward curved, single inlet
with support bracket

Product drawing

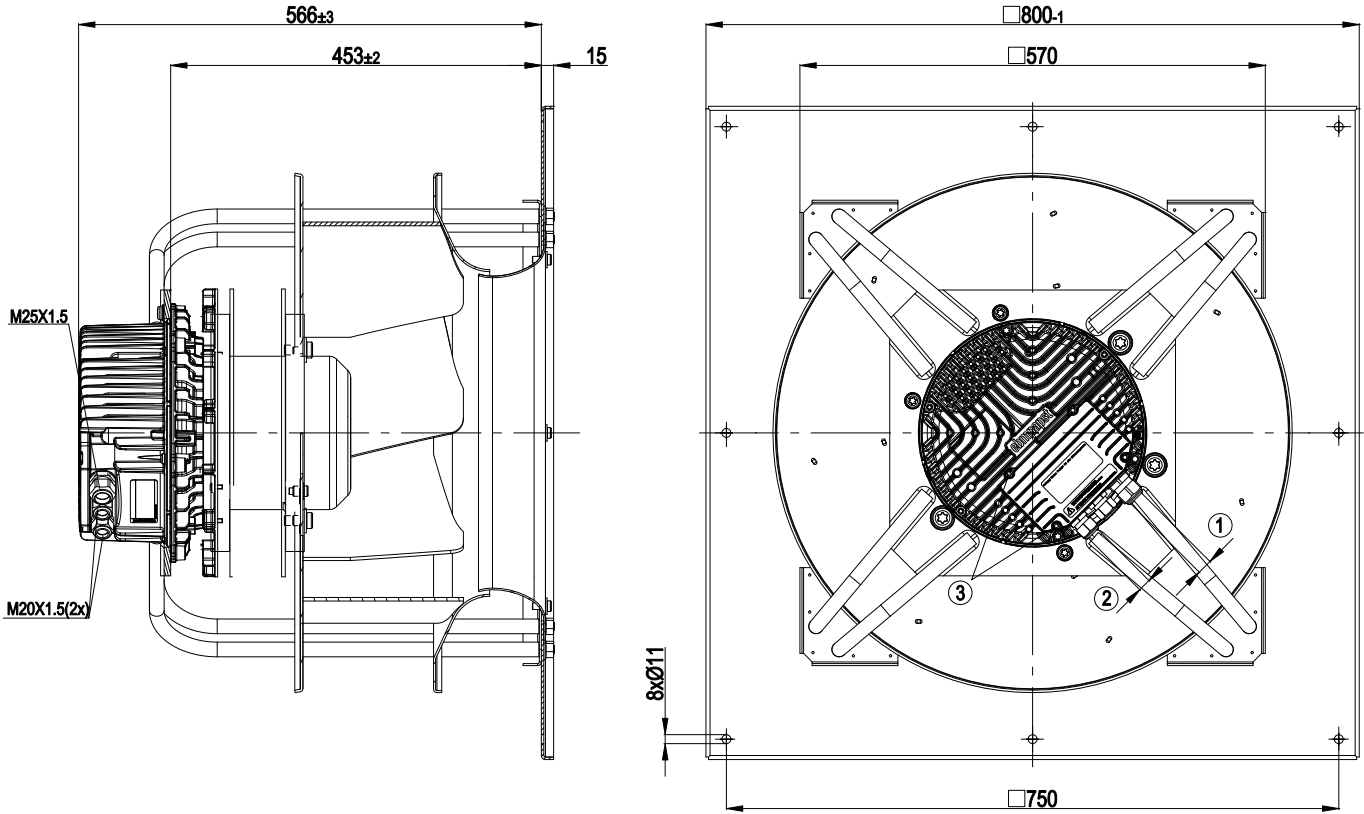

1	Cable diameter: min. 9 mm, max. 16 mm; tightening torque: 6 ± 0.6 Nm
2	Cable diameter: min. 4 mm, max. 10 mm; tightening torque: 4 ± 0.4 Nm
3	Tightening torque 3.5 ± 0.5 Nm

backward curved, single inlet

with support bracket

Connection screen

8	Din 2
9	Din 3
10	GND
11	Ain 2 U
12	+ 20 V
13	Ain 2 I
14	Aout
1	RSA
2	RSB
3	GND
4	Ain 1 U
5	+ 10 V
6	Ain 1 I
7	Din 1

KL 3

1	NO
2	COM
3	NC

KL 2

PE

PE

1	L1
2	L2
3	L3

KL 1

No.	Pin	Signal	Function / assignment
KL 1	1	L1	Mains supply connection, supply voltage 3~380-480 VAC; 50/60 Hz
KL 1	2	L2	Mains supply connection, supply voltage 3~380-480 VAC; 50/60 Hz
KL 1	3	L3	Mains supply connection, supply voltage 3~380-480 VAC; 50/60 Hz
PE		PE	Earth connection, PE connection
KL 2	1	NO	Status relay, floating status contact; normally open; close with error
KL2	2	COM	Status relay; floating status contact; changeover contact; common connection; contact rating 250 VAC / 2 A (AC1)
KL2	3	NC	Status relay, floating status contact; break with error
KL 3	1	RSA	Bus connection RS485; RSA; MODBUS RTU
KL 3	2	RSB	Bus connection RS485; RSB; MODBUS RTU
KL 3	3 / 10	GND	Signal ground for control interface KL3
KL 3	4	Ain1 U	Analogue input 1 (set value); 0-10 V; Ri= 100 kΩ; parametrisable curves; only usable as alternative to input Ain1 I
KL 3	5	+ 10 V	Fixed voltage output 10 VDC; + 10 V +/-3%; max. 10 mA; short circuit proof; power supply for ext. devices (e.g. potentiometer)
KL 3	6	Ain1 I	Analogue input 1 (set value); 4-20 mA; Ri= 100 Ω; parametrisable curves; only usable as alternative to input Ain1 U
KL 3	7	Din1	Digital input 1: enabling of electronics; enabling: open pin or applied voltage 5 to 50 VDC; disabling: bridge to GND or applied voltage < 1 VDC; reset function: triggers software reset after a level change to <1 V
KL 3	8	Din2	Digital input 2: parameter set switch 1/2; according to EEPROM setting, the valid/used parameter set is selectable per BUS or per digital input DIN2. Parameter set 1: open pin or applied voltage 5 to 50 VDC; parameter set 2: bridge to GND or applied voltage < 1 VDC
KL 3	9	Din3	Digital input 3: Control characteristic of the integrated controller; according to EEPROM setting, the control characteristic of the integrated controller is normally/inversely selectable per BUS or per digital input; normal: open pin or applied voltage 5 to 50 VDC (control deviation = actual sensor value - set value) inverse: bridge to GND or applied voltage < 1 VDC (control deviation = set value - actual sensor value)
KL 3	11	Ain2 U	Analogue input 2; actual sensor value 0-10 V; Ri= 100 kΩ; parametrisable curve; only usable as alternative to input Ain2 I
KL 3	12	+ 20 V	Fixed voltage output 20 VDC; + 20 V +/-5/-10 %; max. 50 mA; short circuit proof; power supply for ext. devices (e.g. sensors)
KL 3	13	Ain2 I	Analogue input 2; actual sensor value 4-20 mA; Ri= 100 Ω; parametrisable curve; only usable as alternative to input Ain2 U
KL 3	14	Aout	Analogue output 0-10 V; max. 5 mA; output of the actual motor control factor (output voltage of electronics)/ of the actual motor speed; function selectable per bus; parametrisable curve.

Charts: Air flow 50 Hz

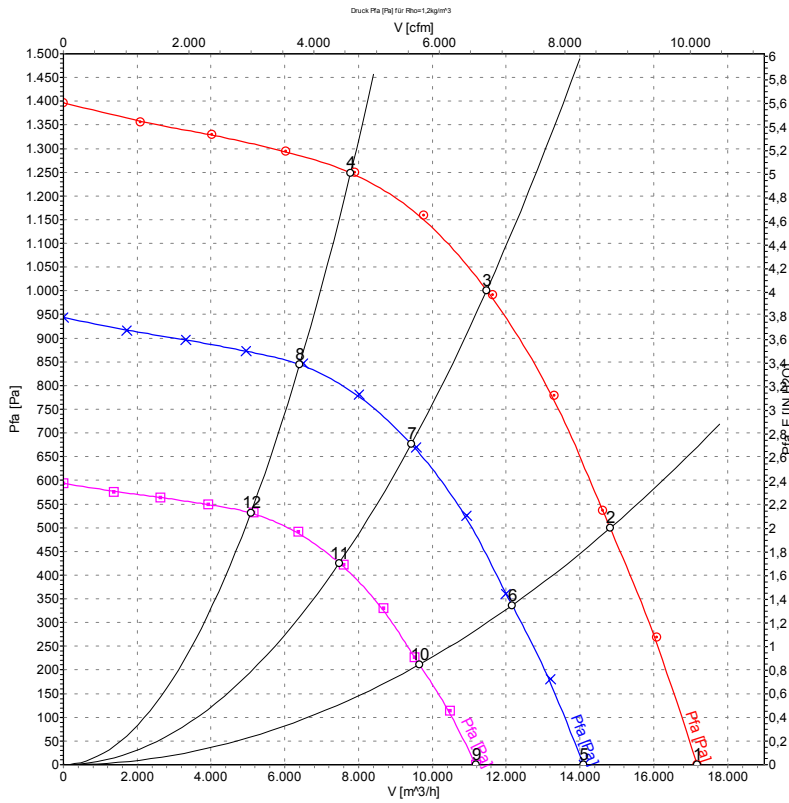

Measurement: LU-128639

Measured values

	U	f	n	P ₁	I	LpA _{ss}	LwA _{ss}	LwA _{ds}	\hat{V}	p _{fa}
	[V]	[Hz]	[min ⁻¹]	[W]	[A]	[dB(A)]	[dB(A)]	[dB(A)]	[m ³ /h]	[Pa]
1	400	50	1750	3032	4.77	88	97	103	17170	0
2	400	50	1750	3929	6.10	84	91	96	14820	500
3	400	50	1750	4700	7.30	78	84	91	11470	1000
4	400	50	1750	4366	6.71	79	86	92	7785	1250
5	400	50	1450	1675	2.64	84	93	98	14090	0
6	400	50	1450	2171	3.37	80	87	92	12160	336
7	400	50	1450	2602	4.01	74	80	86	9430	681
8	400	50	1450	2432	3.74	75	82	88	6405	848
9	400	50	1150	836	1.32	79	88	93	11180	0
10	400	50	1150	1083	1.68	75	82	87	9650	211
11	400	50	1150	1298	2.00	68	75	81	7480	428
12	400	50	1150	1213	1.87	70	76	83	5080	534