

EC centrifugal module

backward curved, single inlet

with support bracket

K3G560-AH02-05 ebmpapst Datasheet

sales@fansco.com

www.fansco.com

Limited partnership · Headquarters Mulfingen
County court Stuttgart · HRA 590344

General partner Elektrobau Mulfingen GmbH · Headquarters Mulfingen
County court Stuttgart · HRB 590142



Nominal data

Type	K3G560-AH02-05	
Motor	M3G150-IF	
Phase		3~
Nominal voltage	VAC	400
Nominal voltage range	VAC	380 .. 480
Frequency	Hz	50/60
Type of data definition		ml
Speed	min ⁻¹	1510
Power input	W	3100
Current draw	A	4.9
Min. ambient temperature	°C	-25
Max. ambient temperature	°C	60

ml = max. load · me = max. efficiency · fa = running at free air · cs = customer specs · cu = customer unit
Subject to alterations

Data according to ErP directive

Installation category	A
Efficiency category	Static
Variable speed drive	Yes
Specific ratio*	1.01

* Specific ratio = $1 + p_{fs} / 100\,000 \text{ Pa}$

		Actual	Request 2013	Request 2015
Overall efficiency η_{es}		59.7	52.6	56.6
Efficiency grade N		65.1	58	62
Power input P_{ed}	kW	3.03		
Air flow q_v	m ³ /h	8745		
Pressure increase p_{fs}	Pa	709		
Speed n	min ⁻¹	1505		

Data established at point of optimum efficiency



Technical features

Mass	43.4 kg
Size	560 mm
Surface of rotor	Coated in black
Material of electronics housing	Die-cast aluminium
Material of impeller	Aluminium sheet
Material of mounting plate	Sheet steel, coated in black
Material of support bracket	Steel, coated in black
Number of blades	9
Direction of rotation	Clockwise, seen on rotor
Type of protection	IP 54
Insulation class	"F"
Humidity class	F5
Max. permissible ambient motor temp. (transp./ storage)	+80 °C
Min. permissible ambient motor temp. (transp./storage)	-40 °C
Mounting position	Refer to product drawing
Condensate discharge holes	Rotor-side
Operation mode	S1
Motor bearing	Ball bearing
Technical features	<ul style="list-style-type: none"> - PFC, passive - Control input 0-10 VDC / PWM - Over-temperature protected electronics / motor - Alarm relay - Integrated PID controller - Input for sensor 0-10 V or 4-20 mA - Output for slave 0-10 V - RS485 ebmBUS - Motor current limit - Soft start - Line undervoltage / phase failure detection - Output 10 VDC, max. 10 mA - Output 20 VDC, max. 50 mA
EMC interference immunity	Acc. to EN 61000-6-2 (industrial environment)
EMC interference emission	Acc. to EN 61000-6-3 (household environment)
Touch current acc. IEC 60990 (measuring network Fig. 4, TN system)	<= 3.5 mA
Electrical leads	Via terminal box
Motor protection	Reverse polarity and locked-rotor protection
Protection class	I (if protective earth is connected by customer)
Product conforming to standard	EN 61800-5-1; CE
Approval	VDE; UL 1004-1; CSA C22.2 Nr.77

EC centrifugal module

backward curved, single inlet
with support bracket

Product drawing

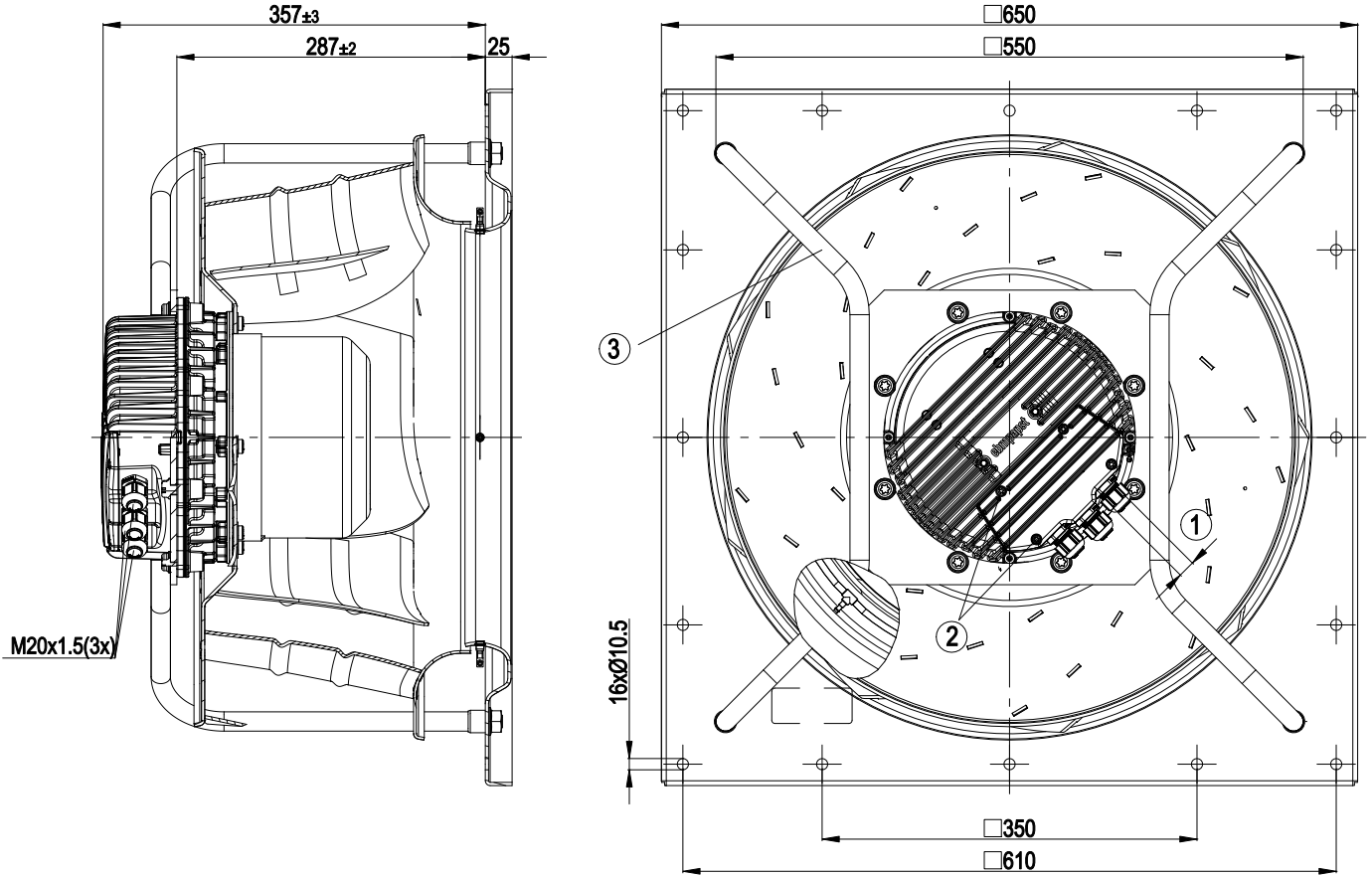

1	Cable diameter: min. 4 mm, max. 10 mm; tightening torque: 4 ± 0.6 Nm
2	Tightening torque 3.5 ± 0.5 Nm
3	Mounting position: shaft horizontal (install the support struts only vertically as shown in the view!) or rotor on bottom; rotor on top on request



EC centrifugal module

backward curved, single inlet
with support bracket

Connection screen

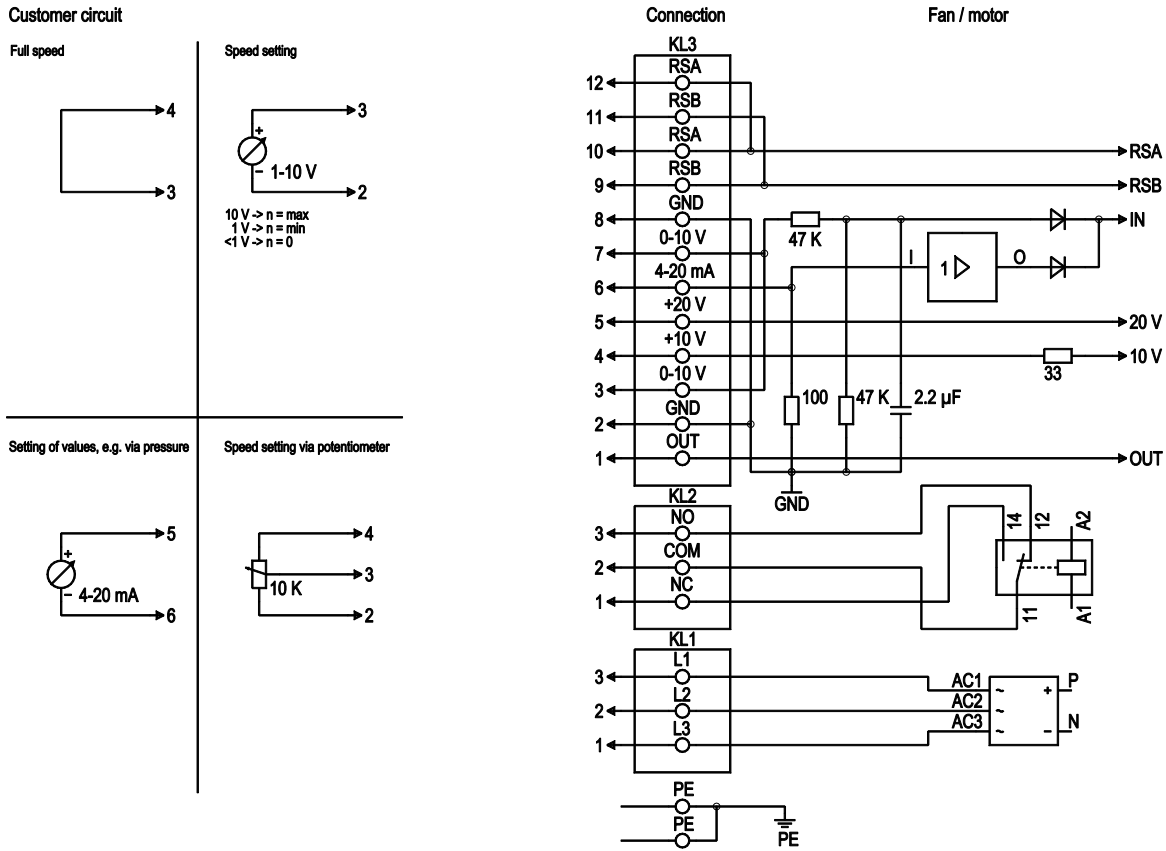

No.	Pin	Signal	Function / assignment
PE		PE	Protective earth connection
KL1	1, 2, 3	L1, L2, L3	Supply voltage, 50/60 Hz
KL2	1	NC	Floating status message contact, normally closed connection
KL2	2	COM	Floating status message contact, changeover contact, common connection (2 A, max. 250 VAC, min. 10 mA, AC1)
KL2	3	NO	Floating status message contact, normally open connection
KL3	1	OUT	Analog output, 0-10 VDC, max. 3 mA, SELV, output of the current level control coefficient: 1 V equates to 10 % level control coefficient. 10 V equate to 100 % level control coefficient.
KL3	2, 8	GND	Reference mass for control interface, SELV
KL3	3, 7	0-10 V	Use control / actual value input 0-10 VDC, impedance 100 kΩ only as alternative to 4-20 mA input, SELV
KL3	4	+10 V	Voltage output 10 VDC (+/-3 %), max. 10 mA, supply voltage for ext. devices (e.g. potentiometers), SELV
KL3	5	+20 V	Voltage output 20 VDC (+25 %/-10 %), max. 50 mA, supply voltage for ext. devices (e.g. sensors), SELV
KL3	6	4-20 mA	Use control / actual value input 4-20 mA, impedance 100 Ω, only as alternative to 0-10 V input, SELV
KL3	9, 11	RSB	RS485 interface for ebmBus, RSB, SELV
KL3	10, 12	RSA	RS485 interface for ebmBus, RSA, SELV



EC centrifugal module

backward curved, single inlet

with support bracket

Charts: Air flow 50 Hz

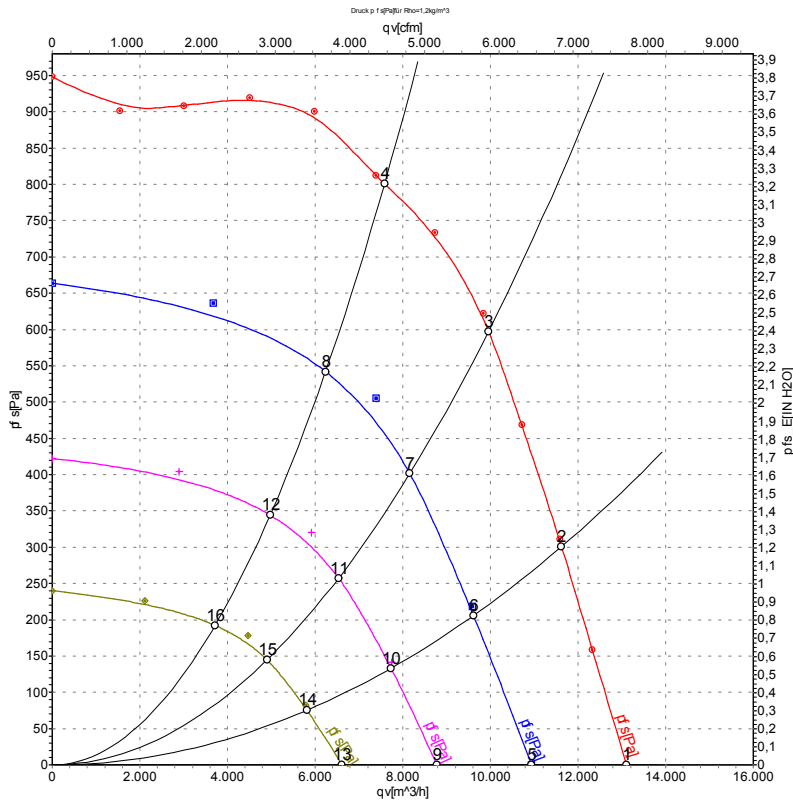

Measurement: LU-109157
 Measurement: LU-111949
 Measurement: LU-111950
 Measurement: LU-111948

Air performance measured as per ISO 5801 Installation category A. For detailed information on the measuring set-up, please contact ebmpapst. Suction-side noise levels: LwA measured as per ISO 13347 / LpA measured with 1m distance to fan axis. The values given are valid under the measuring conditions mentioned above and may vary according to the actual installation situation. With any deviation from the standard set-up, the specific values have to be checked and reviewed with the unit installed.

Measured values

	Conn.	U	f	n	P _{ed}	I	LpA _{in}	LwA _{in}	LwA _{out}	qv	p _{fs}
		V	Hz	min ⁻¹	W	A	dB(A)	dB(A)	dB(A)	m ³ /h	Pa
1	Y	400	50	1510	1965	2.99	80	86	94	13110	0
2	Y	400	50	1510	2553	3.88	78	84	92	11620	300
3	Y	400	50	1510	3100	4.90	76	83	90	9955	600
4	Y	400	50	1510	2981	4.53	75	82	89	7585	800
5	Y	400	50	1250	1082	1.65	74	81	88	10930	0
6	Y	400	50	1250	1392	2.12	72	79	86	9615	216
7	Y	400	50	1250	1579	2.40	71	78	84	8160	405
8	Y	400	50	1250	1557	2.37	71	78	84	6240	546
9	Y	400	50	1000	583	0.95	67	74	81	8775	0
10	Y	400	50	1000	734	1.16	66	73	79	7735	142
11	Y	400	50	1000	826	1.30	65	72	78	6535	260
12	Y	400	50	1000	811	1.27	65	72	78	4970	346
13	Y	400	50	750	272	0.54	60	67	73	6615	0
14	Y	400	50	750	330	0.63	60	67	73	5810	80
15	Y	400	50	750	368	0.69	59	66	72	4900	146
16	Y	400	50	750	357	0.67	58	66	72	3715	193

Conn. = Connection · U = Supply voltage · f = Frequency · n = Speed · P_{ed} = Power input · I = Current draw · LpA_{in} = Sound pressure level inlet side · LwA_{in} = Sound power level inlet side
 LwA_{out} = Sound power level outlet side · qv = Air flow · p_{fs} = Pressure increase

