

K3G500-AQ33-68 ebmpapst Datasheet FansCo

sales@fansco.com

www.fansco.com

Nominal data

| | | |
|--------------------------|-------------------|------------|
| Type | K3G500-AQ33-68 | |
| Motor | M3G150-IF | |
| Phase | | 3~ |
| Nominal voltage | VAC | 400 |
| Nominal voltage range | VAC | 380 .. 480 |
| Frequency | Hz | 50/60 |
| Method of obtaining data | | ml |
| Speed (rpm) | min ⁻¹ | 2200 |
| Power consumption | W | 5400 |
| Current draw | A | 8.1 |
| Min. ambient temperature | °C | -25 |
| Max. ambient temperature | °C | 45 |

ml = Max. load · me = Max. efficiency · fa = Free air · cs = Customer specification · ce = Customer equipment
Subject to change

Data according to ErP Directive

| | | Actual | Req. 2015 | | | |
|-----------------------------------|---|--------|-----------|-------------------------------|-------------------|------|
| 01 Overall efficiency η_{es} | % | 67.1 | 59 | 09 Power consumption P_{ed} | kW | 5.18 |
| 02 Measurement category | | A | | 09 Air flow q_v | m ³ /h | 9940 |
| 03 Efficiency category | | Static | | 09 Pressure increase p_{fs} | Pa | 1205 |
| 04 Efficiency grade N | | 70.1 | 62 | 10 Speed (rpm) n | min ⁻¹ | 2205 |
| 05 Variable speed drive | | Yes | | 11 Specific ratio* | | 1.01 |

Data obtained at optimum efficiency level.

The ErP data is determined using a motor-impeller combination in a standardized measurement setup.

* Specific ratio = $1 + p_{fs} / 100\,000\text{ Pa}$

LU-169587



Technical description

| | |
|---|---|
| Weight | 56.5 kg |
| Fan size | 500 mm |
| Rotor surface | Painted black |
| Electronics housing material | Die-cast aluminum |
| Impeller material | Sheet aluminum |
| Support plate material | Sheet steel, galvanized |
| Support bracket material | Steel, painted black |
| Inlet nozzle material | Sheet steel, galvanized |
| Number of blades | 7 |
| Direction of rotation | Clockwise, viewed toward rotor |
| Degree of protection | IP55 |
| Insulation class | "F" |
| Moisture (F) / Environmental (H) protection class | F4-1 |
| Max. permitted ambient temp. for motor (transport/storage) | +80 °C |
| Min. permitted ambient temp. for motor (transport/storage) | -40 °C |
| Installation position | Shaft horizontal or rotor on bottom; rotor on top on request |
| Condensation drainage holes | On rotor side |
| Mode | S1 |
| Motor bearing | Ball bearing |
| Technical features | <ul style="list-style-type: none"> - Output 10 VDC, max. 10 mA - Output 20 VDC, max. 50 mA - Output for slave 0-10 V - Input for sensor 0-10 V or 4-20 mA - External 24 V input (parameter setting) - External release input - Alarm relay - Integrated PID controller - Motor current limitation - PFC, passive - RS-485 MODBUS-RTU - Soft start - EEPROM write cycles: 100,000 maximum - Control input 0-10 VDC / PWM - Control interface with SELV potential safely disconnected from the mains - Thermal overload protection for electronics/motor - Line undervoltage / phase failure detection |
| EMC immunity to interference | According to EN 61000-6-2 (industrial environment) |
| EMC interference emission | According to EN 61000-6-3 (household environment), except EN 61000-3-2 for professionally used equipment with a total rated power greater than 1 kW |
| Touch current according to IEC 60990 (measuring circuit Fig. 4, TN system) | <= 3.5 mA |
| Electrical hookup | Via terminal box |
| Motor protection | Reverse polarity and locked-rotor protection |
| Protection class | I (with customer connection of protective earth) |
| Conformity with standards | EN 61800-5-1; CE |

K3G500-AQ33-68

EC centrifugal module

backward-curved, single-intake

with support bracket

Approval

EAC; UL 1004-7 + 60730; C22.2 No.77 + CAN/CSA-E60730-1



EC centrifugal module

backward-curved, single-intake
with support bracket

Product drawing

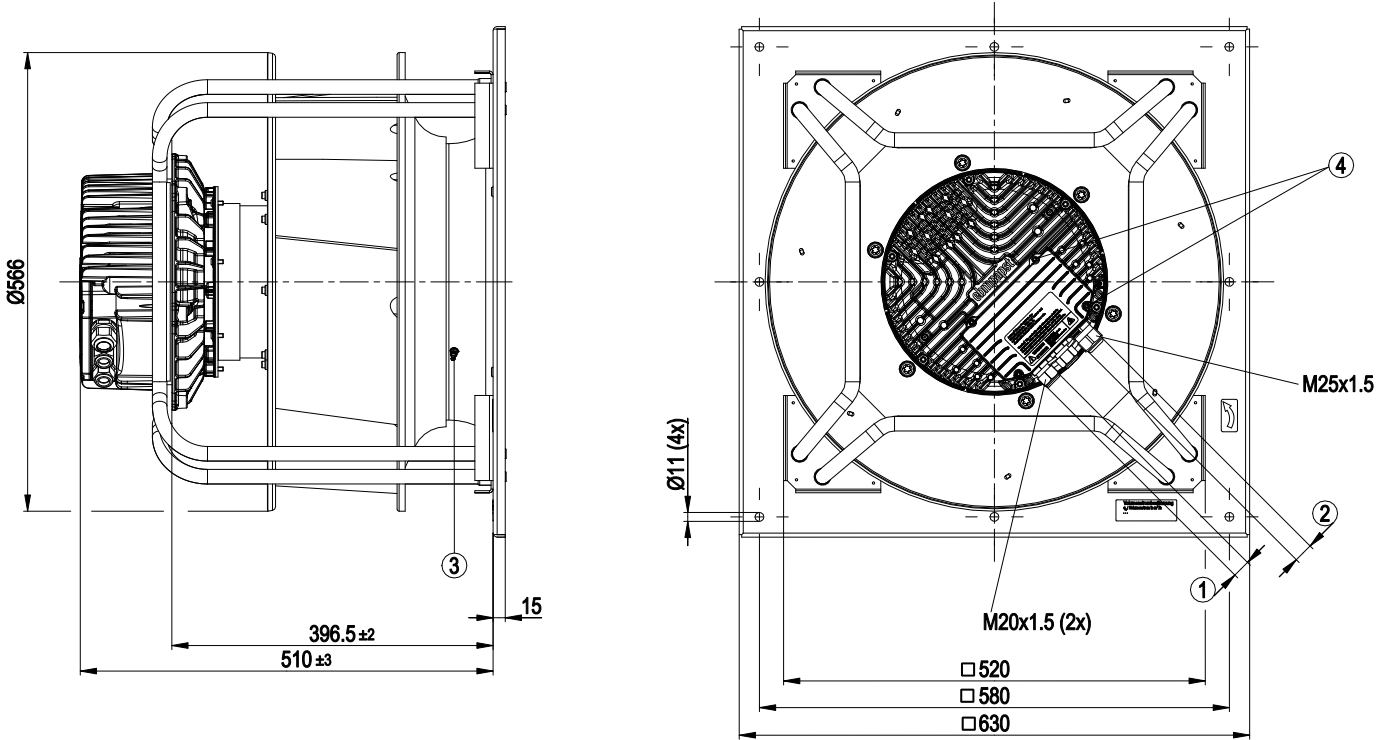

| | |
|---|--|
| 1 | Cable diameter min. 4 mm, max. 10 mm, tightening torque 4 ± 0.6 Nm |
| 2 | Cable diameter min. 9 mm, max. 16 mm, tightening torque 6 ± 0.9 Nm |
| 3 | Inlet ring with pressure tap (k-factor: 281) |
| 4 | Tightening torque 3.5 ± 0.5 Nm |



Connection diagram

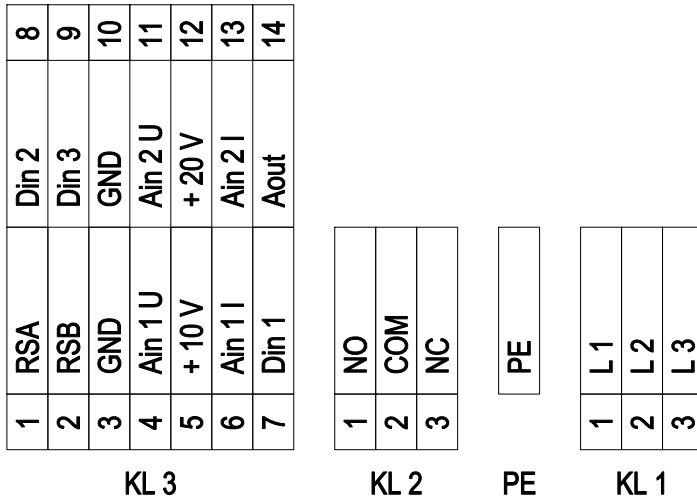

| No. | Conn. | Designation | Function/assignment |
|------|--------|-------------|--|
| KL 1 | 1 | L1 | Supply connection, power supply 3-phase 380-480 VAC, 50/60 Hz |
| KL 1 | 2 | L2 | Supply connection, power supply 3-phase 380-480 VAC, 50/60 Hz |
| KL 1 | 3 | L3 | Supply connection, power supply 3-phase 380-480 VAC, 50/60 Hz |
| PE | | PE | Ground connection, PE connection |
| KL 2 | 1 | NO | Status relay, floating status contact; make for failure |
| KL2 | 2 | COM | Status relay, floating status contact; changeover contact; common connection; contact rating 250 VAC / max. 2 A (AC1) / min. 10 mA |
| KL2 | 3 | NC | Status relay, floating status contact; break for failure |
| KL 3 | 1 | RSA | Bus connection RS485, RSA, MODBUS-RTU; SELV |
| KL 3 | 2 | RSB | Bus connection RS485, RSB, MODBUS-RTU; SELV |
| KL 3 | 3 / 10 | GND | Reference ground for control interface; SELV |
| KL 3 | 4 | Ain1 U | Analog input 1, set value: 0-10 V, Ri = 100 kΩ, adjustable curve, only usable as alternative to input Ain1 I; SELV |
| KL 3 | 5 | + 10 V | Fixed voltage output 10 VDC, +10 V ±3%, max. 10 mA, short-circuit-proof power supply for external devices (e.g. pot); SELV |
| KL 3 | 6 | Ain1 I | Analog input 1, set value: 4-20 mA, Ri = 100 Ω, adjustable curve, only usable as alternative to input Ain1U; SELV |
| KL 3 | 7 | Din1 | Digital input 1: enable electronics, enable: pin open or applied voltage 5-50 VDC disable: bridge to GND or applied voltage < 1 VDC reset function: triggers software reset after a level change to < 1 VDC; SELV |
| KL 3 | 8 | Din2 | Digital input 2: Switching parameter sets 1/2, according to EEPROM setting, the valid or used parameter set can be selected via bus or via digital input DIN2. Parameter set 1: pin open or applied voltage 5-50 VDC Parameter set 2: bridge to GND or applied voltage < 1 VDC; SELV |
| KL 3 | 9 | Din3 | Digital input 3: according to EEPROM setting, the integrated controller's direction of action can be selected as normal/inverse via bus or digital input normal: pin open or applied voltage 5-50 VDC inverse: bridge to GND or applied voltage < 1 VDC; SELV |
| KL 3 | 11 | Ain2 U | Analog input 2, measured value: 0-10 V, Ri = 100 kΩ, adjustable curve, only usable as alternative to input Ain2I; SELV |
| KL 3 | 12 | + 20 V | Fixed voltage output 20 VDC, +20 V ±5/-10%, max. 50 mA, short-circuit-proof power supply for external devices (e.g. sensors); SELV |

EC centrifugal module

backward-curved, single-intake

with support bracket

| No. | Conn. | Designation | Function/assignment |
|------|-------|-------------|--|
| KL 3 | 13 | Ain2 I | Analog input 2, measured value: 4-20 mA, Ri = 100 Ω, adjustable curve, only usable as alternative to input Ain2U; SELV |
| KL 3 | 14 | Aout | Analog output 0-10 VDC, max. 5 mA, output of current motor modulation level / motor speed adjustable curve; SELV |



Curves: Air performance 50 Hz

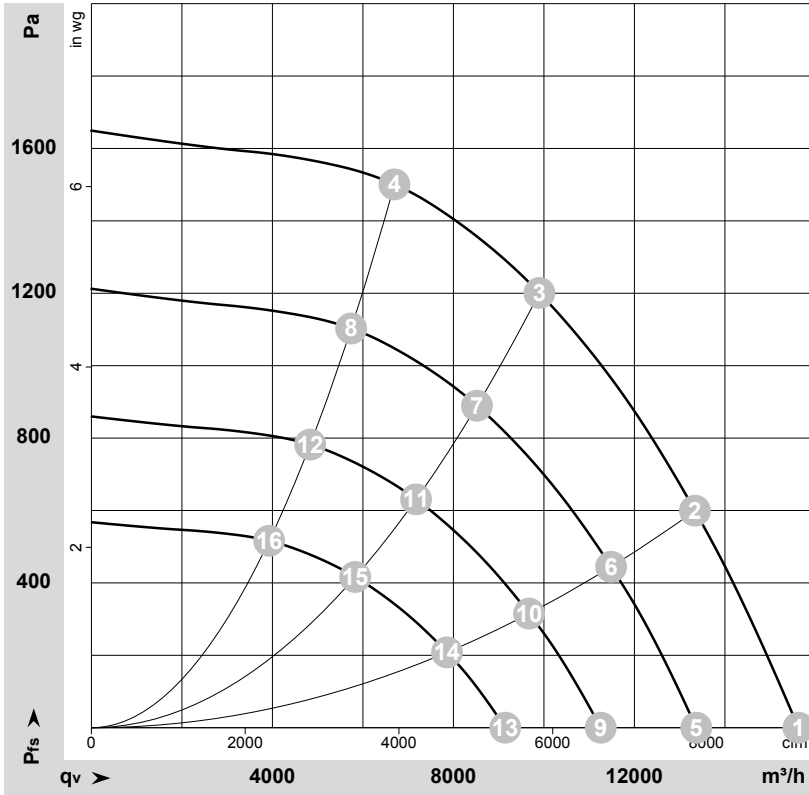

$\rho = 1.15 \text{ kg/m}^3 \pm 2 \%$

Measurement: LU-169587-1

Air performance measured according to ISO 5801 installation category A. For detailed information on the measurement setup, contact ebmpapst. Intake sound level: Sound power level according to ISO 13347 / sound pressure level measured at 1 m distance from fan axis. The values given are valid under the specified measuring conditions and may vary due to conditions of installation. For deviations from the standard configuration, the parameters have to be checked on the installed unit.

Measured values

| | U | f | n | P _{ed} | I | LpA _{in} | LwA _{in} | LwA _{out} | qv | P _{fs} | qv | P _{fs} |
|----|-----|----|-------------------|-----------------|------|-------------------|-------------------|--------------------|-------------------|-----------------|------|--------------------|
| | V | Hz | min ⁻¹ | W | A | dB(A) | dB(A) | dB(A) | m ³ /h | Pa | CFM | inH ₂ O |
| 1 | 400 | 50 | 2200 | 3488 | 5.41 | 90 | 98 | 104 | 15625 | 0 | 9195 | 0.00 |
| 2 | 400 | 50 | 2200 | 4465 | 6.85 | 85 | 93 | 98 | 13340 | 600 | 7850 | 2.41 |
| 3 | 400 | 50 | 2200 | 5400 | 8.10 | 80 | 87 | 94 | 9900 | 1200 | 5825 | 4.82 |
| 4 | 400 | 50 | 2200 | 4991 | 7.65 | 83 | 90 | 96 | 6695 | 1500 | 3940 | 6.02 |
| 5 | 400 | 50 | 1900 | 2184 | 3.39 | 87 | 95 | 100 | 13365 | 0 | 7870 | 0.00 |
| 6 | 400 | 50 | 1900 | 2852 | 4.38 | 81 | 89 | 95 | 11485 | 447 | 6760 | 1.79 |
| 7 | 400 | 50 | 1900 | 3310 | 5.07 | 76 | 84 | 90 | 8520 | 896 | 5015 | 3.60 |
| 8 | 400 | 50 | 1900 | 3143 | 4.81 | 79 | 86 | 92 | 5740 | 1109 | 3380 | 4.45 |
| 9 | 400 | 50 | 1600 | 1304 | 2.02 | 82 | 90 | 95 | 11255 | 0 | 6625 | 0.00 |
| 10 | 400 | 50 | 1600 | 1703 | 2.61 | 77 | 85 | 90 | 9670 | 317 | 5695 | 1.27 |
| 11 | 400 | 50 | 1600 | 1976 | 3.02 | 72 | 79 | 86 | 7175 | 635 | 4225 | 2.55 |
| 12 | 400 | 50 | 1600 | 1877 | 2.87 | 75 | 82 | 88 | 4835 | 787 | 2845 | 3.16 |
| 13 | 400 | 50 | 1300 | 699 | 1.08 | 77 | 85 | 90 | 9145 | 0 | 5385 | 0.00 |
| 14 | 400 | 50 | 1300 | 913 | 1.40 | 72 | 79 | 85 | 7860 | 209 | 4625 | 0.84 |
| 15 | 400 | 50 | 1300 | 1060 | 1.62 | 67 | 74 | 81 | 5830 | 419 | 3430 | 1.68 |
| 16 | 400 | 50 | 1300 | 1007 | 1.54 | 70 | 77 | 83 | 3930 | 519 | 2310 | 2.08 |

U = Power supply · f = Frequency · n = Speed (rpm) · P_{ed} = Power consumption · I = Current draw · LpA_{in} = Sound pressure level intake side · LwA_{in} = Sound power level intake side
LwA_{out} = Sound power level outlet side · qv = Air flow · p_{fs} = Pressure increase

