

backward curved, single inlet

with support bracket

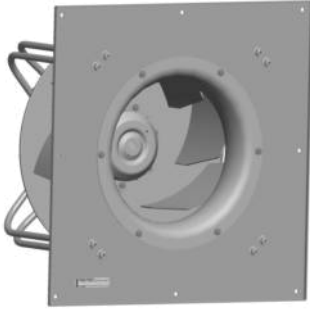

K3G500-AQ12-33 ebmpapst Datasheet

sales@fansco.com

www.fansco.com

Limited partnership · Headquarters Muldingen
County court Stuttgart · HRA 590344

General partner Elektrobau Muldingen GmbH · Headquarters Muldingen
County court Stuttgart · HRB 590142



Nominal data

Type	K3G500-AQ12-33	
Motor	M3G150-IF	
Phase		3~
Nominal voltage	VAC	400
Nominal voltage range	VAC	380 .. 480
Frequency	Hz	50/60
Type of data definition		ml
State		prelim.
Speed	min ⁻¹	2000
Power input	W	4350
Current draw	A	6.7
Min. ambient temperature	°C	-25
Max. ambient temperature	°C	+40

ml = max. load · me = max. efficiency · fa = running at free air · cs = customer specs · cu = customer unit
Subject to alterations

Data according to ErP directive

Installation category	A
Efficiency category	Static
Variable speed drive	Yes
Specific ratio*	1.01

* Specific ratio = $1 + p_{fs} / 100\,000\text{ Pa}$

	Actual	Request 2013	Request 2015
Overall efficiency η_{es}	64.5	54.1	58.1
Efficiency grade N	68.4	58	62
Power input P_{ed}	kW	4.27	
Air flow q_v	m ³ /h	8725	
Pressure increase p_{fs}	Pa	1091	
Speed n	min ⁻¹	2020	

Data established at point of optimum efficiency



backward curved, single inlet
with support bracket

Technical features

Mass	61.7 kg
Size	500 mm
Surface of rotor	Coated in black (cataphoresis coated + UTL)
Material of electronics housing	Die-cast aluminium, coated in black
Material of impeller	Sheet aluminium, laser-welded, coated in black
Material of mounting plate	Sheet steel, hot-galvanised and coated in black
Material of support bracket	Steel, pre-galvanised and coated in black
Material of inlet nozzle	Sheet steel, hot-dip galvanised
Number of blades	7
Direction of rotation	Clockwise, seen on rotor
Type of protection	IP 54
Insulation class	"F"
Humidity class	F4-2
Max. permissible ambient motor temp. (transp./ storage)	+80 °C
Min. permissible ambient motor temp. (transp./storage)	-40 °C
Mounting position	Shaft horizontal or rotor on bottom
Condensate discharge holes	Rotor-side
Operation mode	S1
Motor bearing	Ball bearing
Technical features	<ul style="list-style-type: none"> - PFC, passive - Control input 0-10 VDC / PWM - Output 10 VDC, max. 10 mA - Over-temperature protected electronics / motor - Alarm relay - Integrated PID controller - Input for sensor 0-10 V or 4-20 mA - Output for slave 0-10 V - Output 20 VDC, max. 50 mA - RS485 ebmBUS - Motor current limit - Soft start - Line undervoltage / phase failure detection
EMC interference immunity	Acc. to EN 61000-6-2
EMC interference emission	Acc. to EN 61000-6-3
Touch current acc. IEC 60990 (measuring network Fig. 4, TN system)	<= 3.5 mA
Electrical leads	Via terminal box
Motor protection	Reverse polarity and locked-rotor protection
Protection class	I (if protective earth is connected by customer)
Product conforming to standard	EN 61800-5-1, CE; CE

EC centrifugal module - Plug fan

backward curved, single inlet
with support bracket

Product drawing

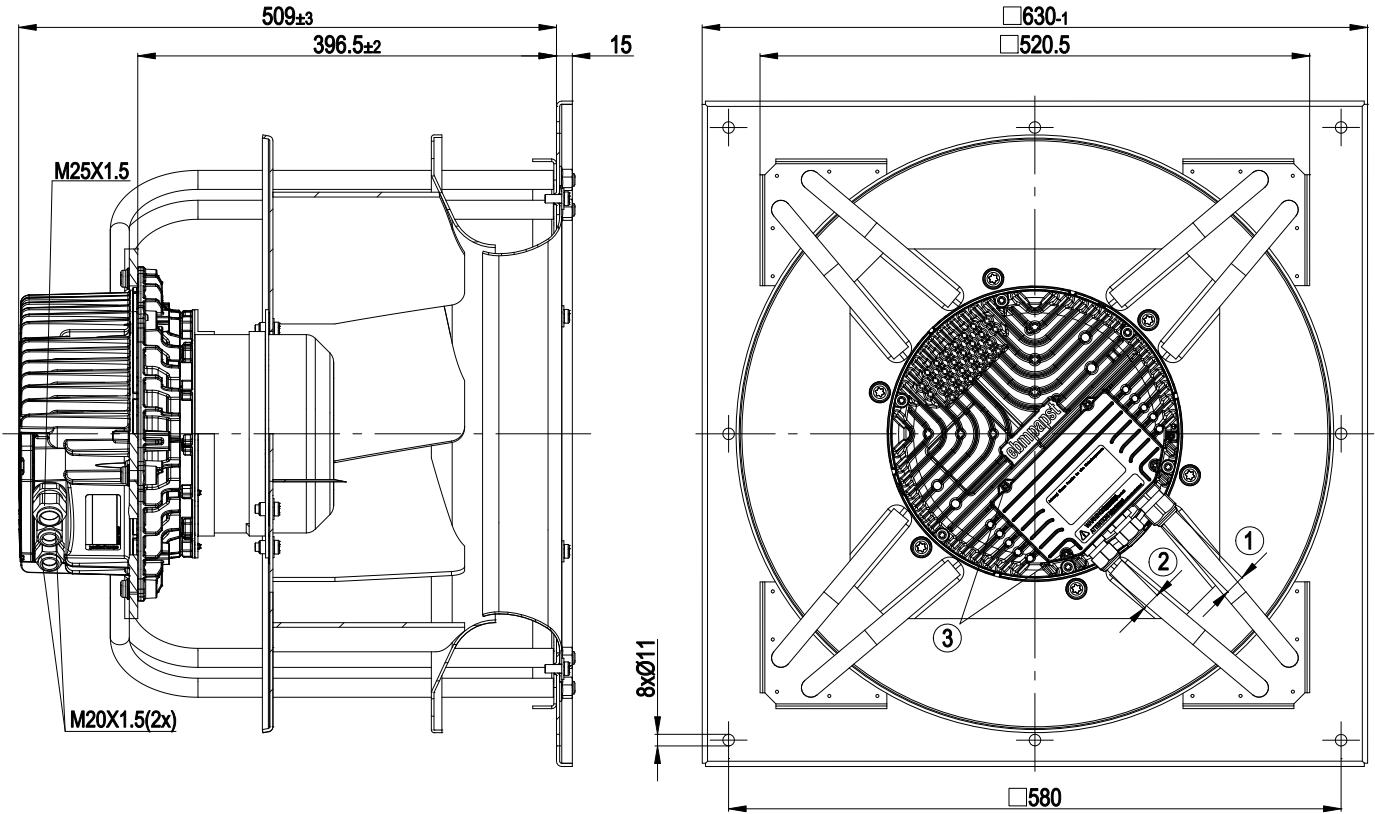

1	Cable diameter: min. 9 mm, max. 16 mm; tightening torque: 6 ± 0.6 Nm
2	Cable diameter: min. 4 mm, max. 10 mm; tightening torque: 4 ± 0.4 Nm
3	Tightening torque 3.5 ± 0.5 Nm



Charts: Air flow 50 Hz

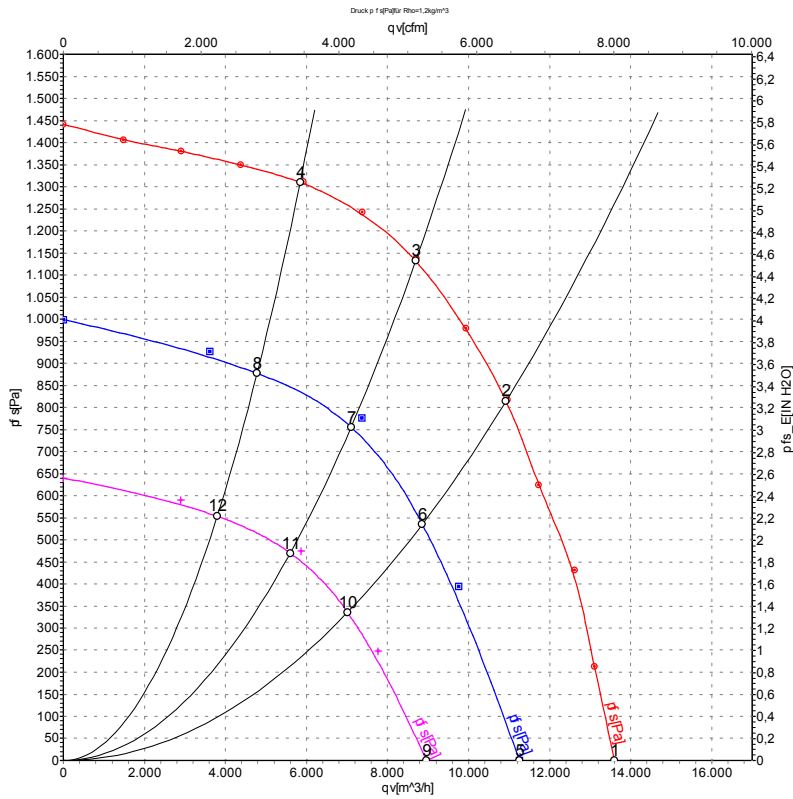

Measurement: LU-109096
 Measurement: LU-117418
 Measurement: LU-117419

Air performance measured as per ISO 5801 Installation category A. For detailed information on the measuring set-up, please contact ebmpapst. Suction-side noise levels: LwA measured as per ISO 13347 / LpA measured with 1m distance to fan axis. The values given are valid under the measuring conditions mentioned above and may vary according to the actual installation situation. With any deviation from the standard set-up, the specific values have to be checked and reviewed with the unit installed.

Measured values

	U	f	n	P _{ed}	I	LpA _{in}	LwA _{in}	qv	p _{fs}
	V	Hz	min ⁻¹	W	A	dB(A)	dB(A)	m ³ /h	Pa
1	400	50	2000	2683	4.07	89	98	13600	0
2	400	50	2000	4038	6.15	80	87	10930	822
3	400	50	2000	4271	6.52	77	84	8695	1140
4	400	50	2000	3813	5.79	80	87	5845	1313
5	400	50	1660	1509	2.33	84	92	11250	0
6	400	50	1660	2042	3.13	75	82	8860	538
7	400	50	1660	2233	3.41	73	79	7100	786
8	400	50	1660	2001	3.07	76	82	4780	879
9	400	50	1320	801	1.32	77	85	8960	0
10	400	50	1320	1067	1.71	69	76	7015	337
11	400	50	1320	1134	1.80	67	74	5600	485
12	400	50	1320	1033	1.66	68	75	3795	555

U = Supply voltage · f = Frequency · n = Speed · P_{ed} = Power input · I = Current draw · LpA_{in} = Sound pressure level inlet side · LwA_{in} = Sound power level inlet side · qv = Air flow
 p_{fs} = Pressure increase

