

# EC centrifugal module - RadiPac

backward curved, single inlet

with support bracket

K3G450-PI88-14 ebmpapst Datasheet

sales@fansco.com

www.fansco.com

Limited partnership · Headquarters Muldingen  
County court Stuttgart · HRA 590344

General partner Elektrobau Muldingen GmbH · Headquarters Muldingen  
County court Stuttgart · HRB 590142

## Nominal data

Type	K3G450-PI88-14	
Motor	M3G112-IA	
Phase		3~
Nominal voltage	VAC	200
Nominal voltage range	VAC	200 .. 240
Frequency	Hz	50/60
Type of data definition		ml
Speed (rpm)	min <sup>-1</sup>	1800
Power input	W	1765
Current draw	A	5.5
Min. ambient temperature	°C	-40
Max. ambient temperature	°C	55

ml = Max. load · me = Max. efficiency · fa = Running at free air · cs = Customer specs · cu = Customer unit  
Subject to alterations

## Data in accordance with ecodesign regulation EU 327/2011 (EN 17166)

		Actual	Request 2015			
01 Overall efficiency $\eta_{es}$	%	68.4	54.5	09 Power input $P_{ed}$	kW	1.91
02 Measurement category		A		09 Air flow $q_v$	m <sup>3</sup> /h	5370
03 Efficiency category		Static		09 Pressure increase $p_{fs}$	Pa	824
04 Efficiency grade N		75.9	62	10 Speed (rpm) n	min <sup>-1</sup>	1820
05 Variable speed drive		Yes		11 Specific ratio*		1.01

Data definition with optimum efficiency.  
The ErP data is determined using a motor-impeller combination in a standardised measurement configuration.

\* Specific ratio =  $1 + p_{fs} / 100\,000\text{ Pa}$

LU-197534



## Technical features

Mass	32 kg
Size	450 mm
Motor size	112
Surface of rotor	Coated in black
Material of electronics housing	Die-cast aluminium
Material of impeller	Aluminium sheet
Material of mounting plate	Sheet steel, galvanised
Material of support bracket	Steel, coated in black
Material of inlet nozzle	Sheet steel, galvanised
Number of blades	7
Direction of rotation	Clockwise, seen on rotor
Type of protection	IP54
Insulation class	"B"
Humidity (F) / environmental protection class (H)	H1
Note ambient temperature	Occasional start-up between -40 °C and -25 °C is permissible. For continuous operation at ambient temperatures below -25 °C (e.g. refrigeration applications), a fan version with special low-temperature bearings must be used.
Max. permissible ambient motor temp. (transp./ storage)	+80 °C
Min. permissible ambient motor temp. (transp./storage)	-40 °C
Mounting position	Refer to product drawing
Condensation drainage holes	Rotor-side
Operation mode	S1
Motor bearing	Ball bearing
Technical features	<ul style="list-style-type: none"> <li>- Output 10 VDC, max. 10 mA</li> <li>- Output 20 VDC, max. 50 mA</li> <li>- Output for slave 0-10 V</li> <li>- Operation and alarm display</li> <li>- Input for sensor 0-10 V or 4-20 mA</li> <li>- External 24 V input (programming)</li> <li>- External release input</li> <li>- Alarm relay</li> <li>- Integrated PID controller</li> <li>- Motor current limit</li> <li>- PFC, passive</li> <li>- RS485 MODBUS RTU</li> <li>- Soft start</li> <li>- Control input 0-10 VDC / PWM</li> <li>- Control interface with SELV potential safely disconnected from the mains</li> <li>- Over-temperature protected electronics / motor</li> <li>- Line undervoltage / phase failure detection</li> </ul>
EMC interference immunity	Acc. to EN 61000-6-2 (industrial environment)
EMC interference emission	Acc. to EN 61000-6-4 (industrial environment)
Touch current acc. IEC 60990 (measuring network Fig. 4, TN system)	<= 3.5 mA
Electrical connection	Terminal box

K3G450-PI88-14

## EC centrifugal module - RadiPac

backward curved, single inlet

with support bracket

<b>Motor protection</b>	Thermal overload protector (TOP) wired internally
<b>Protection class</b>	I (if protective earth is connected by customer)
<b>Product conforming to standard</b>	EN 61800-5-1; CE
<b>Approval</b>	CSA C22.2 no. 77 + CAN/CSA-E60730-1; EAC; UL 1004-7 + 60730-1



# EC centrifugal module - RadiPac

backward curved, single inlet  
with support bracket

## Product drawing

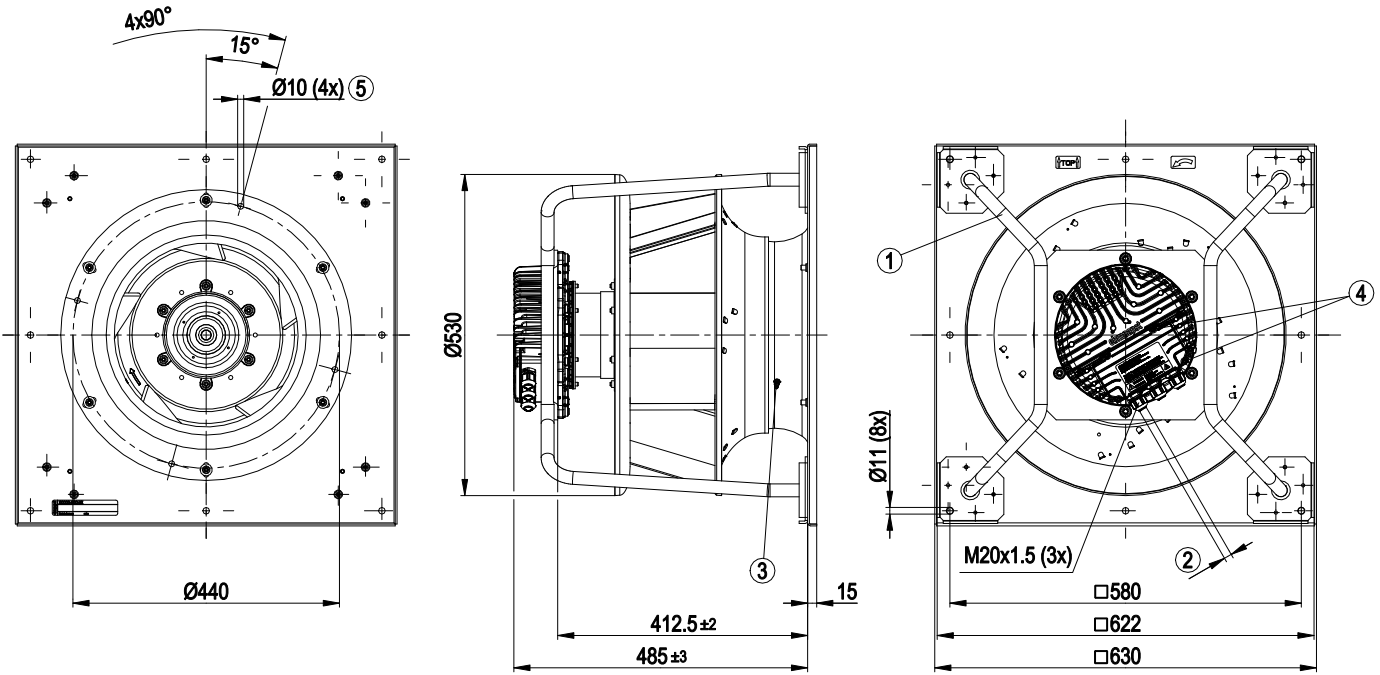

1	Installation position: Shaft horizontal (install the support struts only vertically as shown in the illustration!) or rotor on bottom; rotor on top on request
2	Cable diameter min. 4 mm, max. 10 mm, tightening torque $4 \pm 0.6$ Nm
3	Inlet nozzle with pressure tap (k-factor: 240)
4	Tightening torque $3.5 \pm 0.5$ Nm
5	Mounting holes for FlowGrid



# EC centrifugal module - RadiPac

backward curved, single inlet  
with support bracket

## Connection screen

	8	Din 2
	9	Din 3
	10	GND
	11	Ain 2 U
	12	+ 20 V
	13	Ain 2 I
	14	Aout
1	RSA	
2	RSB	
3	GND	
4	Ain 1 U	
5	+ 10 V	
6	Ain 1 I	
7	Din 1	

KL 3

1	NO
2	COM
3	NC

KL 2

PE
----

PE

1	L1
2	L2
3	L3

KL 1

No.	Conn.	Designation	Function / assignment
KL 1	1	L1	Mains supply connection, supply voltage 3~200-240 VAC; 50/60 Hz
KL 1	2	L2	Mains supply connection, supply voltage 3~200-240 VAC; 50/60 Hz
KL 1	3	L3	Mains supply connection, supply voltage 3~200-240 VAC; 50/60 Hz
PE		PE	Earth connection, PE connection
KL 2	1	NO	Status relay, floating status contact; normally open; close with error
KL2	2	COM	Status relay; floating status contact; changeover contact; common connection; contact rating 250 VAC / max. 2 A (AC1) / min. 10 mA
KL2	3	NC	Status relay, floating status contact; break with error
KL 3	1	RSA	Bus connection RS-485, RSA, MODBUS RTU; SELV
KL 3	2	RSB	Bus connection RS-485, RSB, MODBUS RTU; SELV
KL 3	3 / 10	GND	Signal ground for control interface; SELV
KL 3	4	Ain1 U	Analogue input 1, set value: 0-10 V, Ri = 100 kΩ, parametrisable curve, only usable as alternative to input Ain1; SELV
KL 3	5	+ 10 V	Fixed voltage output 10 VDC, +10 V ±3%, max. 10 mA, short-circuit-proof, power supply for external devices (e.g. potentiometer), SELV
KL 3	6	Ain1 I	Analogue input 1, set value: 4-20 mA; Ri = 100 Ω, parametrisable curve, only usable as alternative to input Ain1 U; SELV
KL 3	7	Din1	Digital input 1: enabling of electronics, enabling: open pin or applied voltage 5-50 VDC disabling: bridge to GND or applied voltage <1 VDC reset function: triggers software reset after a level change to <1 VDC; SELV
KL 3	8	Din2	Digital input 2: parameter set switch 1/2, according to EEPROM setting, the valid/used parameter set can be selected via bus or via digital input DIN2. Parameter set 1: open pin or applied voltage 5-50 VDC Parameter set 2: bridge to GND or applied voltage <1 VDC; SELV
KL 3	9	Din3	Digital input 3: controller function of integrated controller, according to EEPROM setting, the controller function of the integrated controller is normally/inversely selectable per bus or per digital input normal: open pin or applied voltage 5-50 VDC inverse: bridge to GND or applied voltage <1 VDC; SELV
KL 3	11	Ain2 U	Analogue input 2, actual value: 0-10 V, Ri = 100 kΩ, parametrisable curve, only usable as alternative to input Ain2; SELV
KL 3	12	+ 20 V	Fixed voltage output 20 VDC, +20 V ±25/-10%, max. 50 mA, short-circuit-proof, power supply for external devices (e.g. sensors); SELV



# EC centrifugal module - RadiPac

backward curved, single inlet

with support bracket

No.	Conn.	Designation	Function / assignment
KL 3	13	Ain2 I	Analogue input 2, actual value: 4-20 mA, $R_i = 100 \Omega$ , parametrisable curve, only usable as alternative to input Ain2 U; SELV
KL 3	14	Aout	Analogue output 0-10 VDC, max. 5 mA, output of the current motor level control coefficient / motor speed parametrisable curve; SELV



# EC centrifugal module - RadiPac

backward curved, single inlet  
with support bracket

## Charts: Air flow 50 Hz

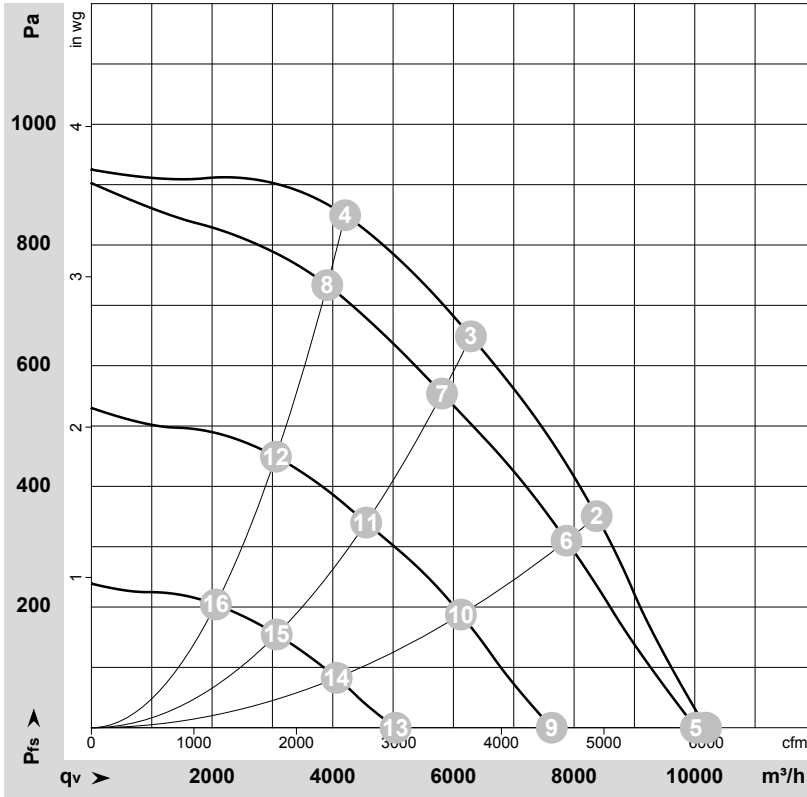

$\rho = 1.15 \text{ kg/m}^3 \pm 2 \%$

Measurement: LU-176848-1

Air performance measured as per ISO 5801 Installation category A. For detailed information on the measuring set-up, please contact ebmpapst. Suction-side noise levels: LwA measured as per ISO 13347 / LpA measured with 1m distance to fan axis. The values given are valid under the measuring conditions mentioned above and may vary according to the actual installation situation. With any deviation from the standard set-up, the specific values have to be checked and reviewed with the unit installed.

## Measured values

	U	f	n	P <sub>ed</sub>	I	LpA <sub>in</sub>	LwA <sub>in</sub>	LwA <sub>out</sub>	q <sub>v</sub>	P <sub>fs</sub>	q <sub>v</sub>	P <sub>fs</sub>
	V	Hz	min <sup>-1</sup>	W	A	dB(A)	dB(A)	dB(A)	m <sup>3</sup> /h	Pa	cfm	in. wg
1	200	50	1800	1015	3.22	84	92	93	10185	0	5995	0.00
2	200	50	1800	1509	4.67	77	84	86	8375	350	4930	1.41
3	200	50	1800	1765	5.50	70	77	82	6290	650	3700	2.61
4	200	50	1800	1687	5.21	74	81	86	4205	850	2475	3.41
5	200	50	1760	963	3.06	84	91	92	10015	0	5895	0.00
6	200	50	1690	1266	3.95	76	82	85	7875	311	4635	1.25
7	200	50	1660	1407	4.37	67	75	80	5810	554	3420	2.22
8	200	50	1665	1368	4.25	71	79	84	3910	736	2300	2.95
9	200	50	1350	460	1.68	76	85	88	7630	0	4490	0.00
10	200	50	1315	617	2.09	68	75	79	6125	188	3605	0.75
11	200	50	1300	695	2.31	63	70	74	4555	340	2680	1.36
12	200	50	1305	670	2.24	65	73	78	3060	450	1800	1.81
13	200	50	895	168	0.70	64	74	74	5040	0	2965	0.00
14	200	50	880	214	0.87	56	65	69	4065	83	2395	0.33
15	200	50	880	246	0.97	53	60	65	3070	155	1805	0.62
16	200	50	880	237	0.94	55	62	67	2060	205	1215	0.82

U = Supply voltage · f = Frequency · n = Speed (rpm) · P<sub>ed</sub> = Power input · I = Current draw · LpA<sub>in</sub> = Sound pressure level inlet side · LwA<sub>in</sub> = Sound power level inlet side · LwA<sub>out</sub> = Sound power level outlet side  
q<sub>v</sub> = Air flow · P<sub>fs</sub> = Pressure increase

