

K3G450-PA23-71 ebmpapst Datasheet

sales@fansco.com

www.fansco.com

Nominal data

Type	K3G450-PA23-71	
Motor	M3G150-FF	
Phase		3~
Nominal voltage	VAC	400
Nominal voltage range	VAC	380 .. 480
Frequency	Hz	50/60
Method of obtaining data		ml
Speed (rpm)	min ⁻¹	2140
Power consumption	W	2900
Current draw	A	4.5
Min. ambient temperature	°C	-25
Max. ambient temperature	°C	60

ml = Max. load · me = Max. efficiency · fa = Free air · cs = Customer specification · ce = Customer equipment
Subject to change

Data according to Commission Regulation (EU) 327/2011 (EN 17166)

		Actual	Req. 2015			
01 Overall efficiency η_{es}	%	70.1	56.4	09 Power consumption P_{ed}	kW	2.89
02 Measurement category		A		09 Air flow q_v	m ³ /h	6655
03 Efficiency category		Static		09 Pressure increase p_{fs}	Pa	1050
04 Efficiency grade N		75.7	62	10 Speed (rpm) n	min ⁻¹	2155
05 Variable speed drive		Yes		11 Specific ratio*		1.01

Data obtained at optimum efficiency level.

The ErP data is determined using a motor-impeller combination in a standardized measurement setup.

* Specific ratio = $1 + p_{fs} / 100\,000\text{ Pa}$

LU-175860



Technical description

Weight	37 kg
Size	450 mm
Motor size	150
Rotor surface	Painted black
Electronics housing material	Die-cast aluminum
Impeller material	Sheet aluminum
Support plate material	Sheet steel, galvanized
Support bracket material	Steel, painted black
Inlet nozzle material	Sheet steel, galvanized
Number of blades	5
Direction of rotation	Clockwise, viewed toward rotor
Degree of protection	IP55
Insulation class	"F"
Moisture (F) / Environmental (H) protection class	H1
Max. permitted ambient temp. for motor (transport/storage)	+80 °C
Min. permitted ambient temp. for motor (transport/storage)	-40 °C
Installation position	See product drawing
Condensation drainage holes	On rotor side
Mode	S1
Motor bearing	Ball bearing
Technical features	<ul style="list-style-type: none"> - Output 10 VDC, max. 10 mA - Operation and alarm display - External 24 V input (parameter setting) - External release input - Alarm relay - Integrated PID controller - Motor current limitation - PFC, passive - RS-485 MODBUS-RTU - Soft start - Control input 0-10 VDC / PWM - Control interface with SELV potential safely disconnected from the mains - Thermal overload protection for electronics/motor - Line undervoltage / phase failure detection
Touch current according to IEC 60990 (measuring circuit Fig. 4, TN system)	<= 3.5 mA
Electrical hookup	Terminal box
Motor protection	Reverse polarity and locked-rotor protection
Protection class	I (with customer connection of protective earth)
Conformity with standards	EN 61800-5-1; CE
Approval	EAC

EC centrifugal module - RadiPac

backward-curved, single-intake
with support bracket

Product drawing

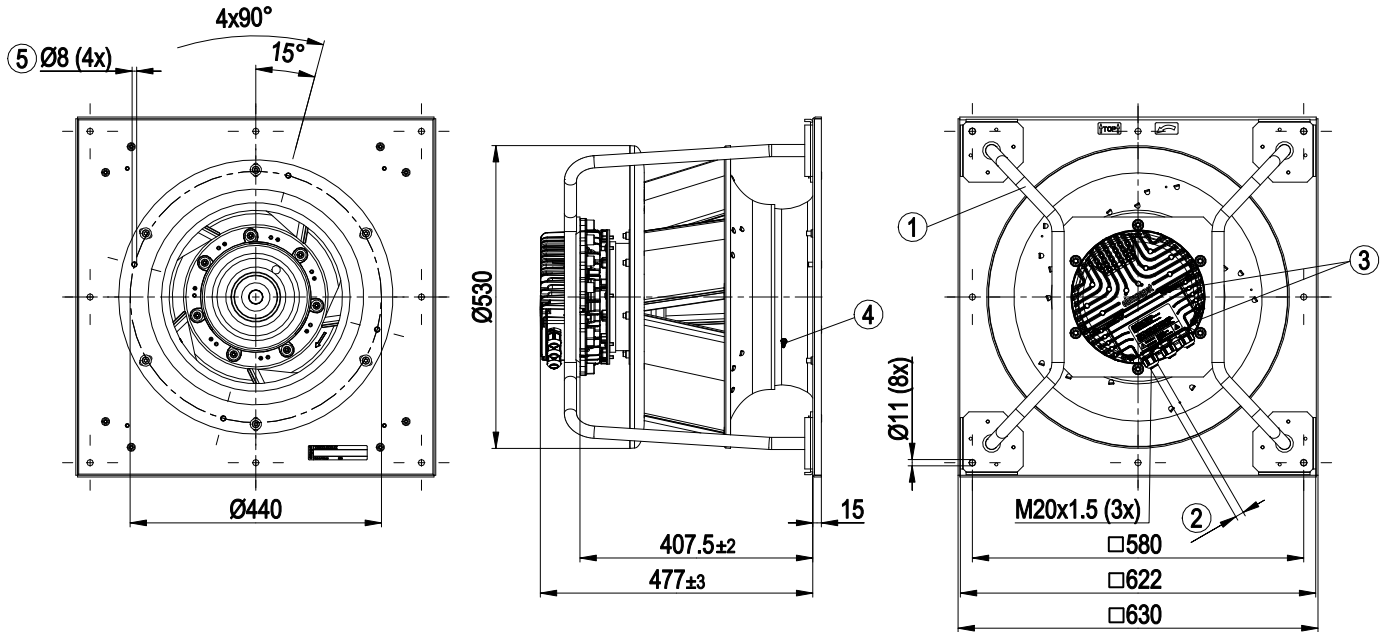

1	Installed position: shaft horizontal (install support struts only vertically as illustrated) or rotor on bottom; rotor on top on request
2	Cable diameter min. 4 mm, max. 10 mm, tightening torque 4 ± 0.6 Nm
3	Tightening torque 3.5 ± 0.5 Nm
4	Inlet ring with pressure tap (k-factor: 240)
5	Mounting holes for FlowGrid



EC centrifugal module - RadiPac

backward-curved, single-intake
with support bracket

Connection diagram

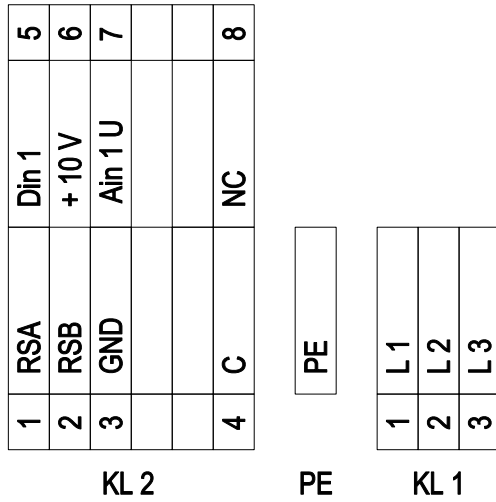

No.	Conn.	Designation	Function/assignment
KL 1	1	L1	Supply connection, power supply 3-phase 380-480 VAC, 50/60 Hz
KL 1	2	L2	Supply connection, power supply 3-phase 380-480 VAC, 50/60 Hz
KL 1	3	L3	Supply connection, power supply 3-phase 380-480 VAC, 50/60 Hz
PE		PE	Ground connection, PE connection
KL 2	1	RSA	Bus connection RS485, RSA, MODBUS-RTU; SELV
KL 2	2	RSB	Bus connection RS485, RSB, MODBUS-RTU; SELV
KL 2	3	GND	Reference ground for control interface; SELV
KL2	4	C	Status relay, floating status contact, break for failure; contact rating 250 VAC / max. 2 A (AC1) / min. 10 mA
KL 2	5	Din1	Digital input 1 enable electronics, enable: pin open or applied voltage 5-50 VDC disable: bridge to GND or applied voltage < 1 VDC reset function: triggers software reset after a level change to < 1 V; SELV
KL 2	6	+ 10 V	Fixed voltage output 10 VDC, +10 V ±3%, max. 10 mA, short-circuit-proof, power supply for external devices (e.g. pot); SELV Or: +24 VDC input for parameter setting via MODBUS without line voltage
KL 2	7	Ain1 U	Analog input 1 (set value) 0-10 V, Ri = 100 kΩ, adjustable curve; SELV
KL2	8	NC	Status relay, floating status contact, break for failure



Curves: Air performance 50 Hz

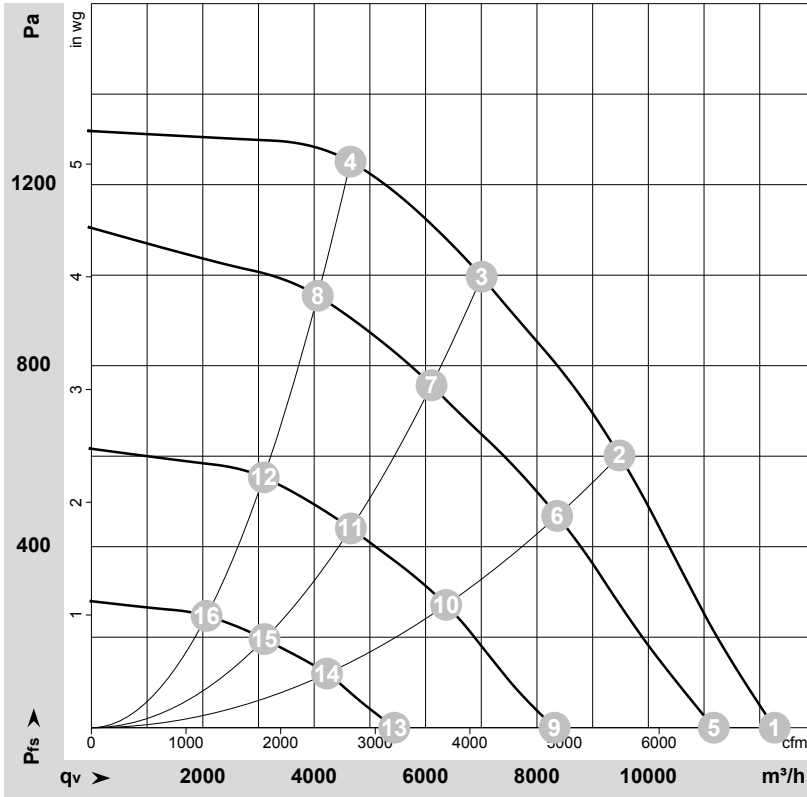

$\rho = 1.15 \text{ kg/m}^3 \pm 2 \%$

Measurement: LU-175860-1

Air performance measured according to ISO 5801 installation category A. For detailed information on the measurement setup, contact ebmpapst. Intake sound level: Sound power level according to ISO 13347 / sound pressure level measured at 1 m distance from fan axis. The values given are valid under the specified measuring conditions and may vary due to conditions of installation. For deviations from the standard configuration, the parameters have to be checked on the installed unit.

Measured values

	U	f	n	P _{ed}	I	LpA _{in}	LwA _{in}	LwA _{out}	q _v	P _{fs}	q _v	P _{fs}
	V	Hz	min ⁻¹	W	A	dB(A)	dB(A)	dB(A)	m ³ /h	Pa	cfm	in. wg
1	400	50	2140	1709	2.69	89	96	95	12265	0	7220	0.00
2	400	50	2140	2655	4.09	78	85	88	9480	600	5580	2.41
3	400	50	2140	2900	4.50	74	81	87	7010	1000	4125	4.01
4	400	50	2140	2763	4.25	79	86	90	4655	1250	2740	5.02
5	400	50	1960	1302	2.11	86	93	93	11175	0	6580	0.00
6	400	50	1890	1825	2.87	74	82	85	8365	469	4925	1.88
7	400	50	1875	1938	3.03	71	78	83	6105	757	3595	3.04
8	400	50	1885	1851	2.90	75	82	87	4065	954	2390	3.83
9	400	50	1470	580	1.14	79	87	87	8315	0	4895	0.00
10	400	50	1435	827	1.45	68	75	79	6370	272	3750	1.09
11	400	50	1430	879	1.52	65	72	77	4660	440	2740	1.77
12	400	50	1435	840	1.47	68	75	80	3095	553	1820	2.22
13	400	50	980	208	0.57	66	75	76	5440	0	3200	0.00
14	400	50	960	277	0.69	57	65	69	4230	121	2490	0.49
15	400	50	955	295	0.72	56	63	68	3110	196	1830	0.79
16	400	50	960	283	0.70	58	65	70	2070	247	1215	0.99

U = Voltage · f = Frequency · n = Speed (rpm) · P_{ed} = Power consumption · I = Current draw · LpA_{in} = Sound pressure level intake side · LwA_{in} = Sound power level intake side
LwA_{out} = Sound power level outlet side · q_v = Air flow · P_{fs} = Pressure increase

