

K3G450-AZ24-68

EC centrifugal module - RadiPac

backward curved, single inlet

with support bracket



K3G450-AZ24-68 ebmpapst Datasheet

sales@fansco.com

www.fansco.com

Limited partnership · Headquarters Muldingen
County court Stuttgart · HRA 590344

General partner Elektrobau Muldingen GmbH · Headquarters Muldingen
County court Stuttgart · HRB 590142

Nominal data

Type	K3G450-AZ24-68	
Motor	M3G150-IF	
Phase		3~
Nominal voltage	VAC	400
Nominal voltage range	VAC	380 .. 480
Frequency	Hz	50/60
Type of data definition		ml
Speed (rpm)	min ⁻¹	2750
Power input	W	5050
Current draw	A	7.95
Min. ambient temperature	°C	-25
Max. ambient temperature	°C	40

ml = Max. load · me = Max. efficiency · fa = Running at free air · cs = Customer specs · cu = Customer unit
Subject to alterations

Data according to ErP directive

		Actual	Request 2015			
01 Overall efficiency η_{es}	%	64.5	58.9	09 Power input P_{ed}	kW	5.05
02 Measurement category		A		09 Air flow q_v	m ³ /h	7485
03 Efficiency category		Static		09 Pressure increase p_{fs}	Pa	1499
04 Efficiency grade N		67.6	62	10 Speed (rpm) n	min ⁻¹	2760
05 Variable speed drive		Yes		11 Specific ratio*		1.02

Data definition with optimum efficiency.
The ErP data is determined using a motor-impeller combination in a standardised measurement configuration.

* Specific ratio = $1 + p_{fs} / 100\,000\text{ Pa}$

LU-173540



Technical features

Mass	52.7 kg
Size	450 mm
Surface of rotor	Coated in black
Material of electronics housing	Die-cast aluminium
Material of impeller	Aluminium sheet
Material of mounting plate	Sheet steel, galvanised
Material of support bracket	Steel, coated in black
Material of inlet nozzle	Sheet steel, galvanised
Number of blades	7
Direction of rotation	Clockwise, seen on rotor
Type of protection	IP 55
Insulation class	"F"
Humidity (F)/environmental protection class (H)	F4-1
Max. permissible ambient motor temp. (transp./ storage)	+80 °C
Min. permissible ambient motor temp. (transp./storage)	-40 °C
Mounting position	Shaft horizontal or rotor on bottom; rotor on top on request
Condensate discharge holes	Rotor-side
Operation mode	S1
Motor bearing	Ball bearing
Technical features	<ul style="list-style-type: none"> - Output 10 VDC, max. 10 mA - Output 20 VDC, max. 50 mA - Output for slave 0-10 V - Operation and alarm display - Input for sensor 0-10 V or 4-20 mA - External 24 V input (programming) - External release input - Alarm relay - Integrated PID controller - Output limit - Motor current limit - PFC, passive - RS485 MODBUS RTU - Soft start - Control input 0-10 VDC / PWM - Control interface with SELV potential safely disconnected from the mains - Over-temperature protected electronics / motor - Line undervoltage / phase failure detection
EMC interference immunity	Acc. to EN 61000-6-2 (industrial environment)
EMC interference emission	Acc. to EN 61000-6-3 (household environment), except EN 61000-3-2 for professionally used devices with a total rated power greater than 1 kW
Touch current acc. IEC 60990 (measuring network Fig. 4, TN system)	<= 3.5 mA
Electrical leads	Via terminal box
Motor protection	Reverse polarity and locked-rotor protection
Protection class	I (if protective earth is connected by customer)

K3G450-AZ24-68

EC centrifugal module - RadiPac

backward curved, single inlet

with support bracket

Product conforming to standard	EN 61800-5-1; CE
Approval	C22.2 Nr.77 + CAN/CSA-E60730-1; EAC; UL 1004-7 + 60730



EC centrifugal module - RadiPac

backward curved, single inlet
with support bracket

Product drawing

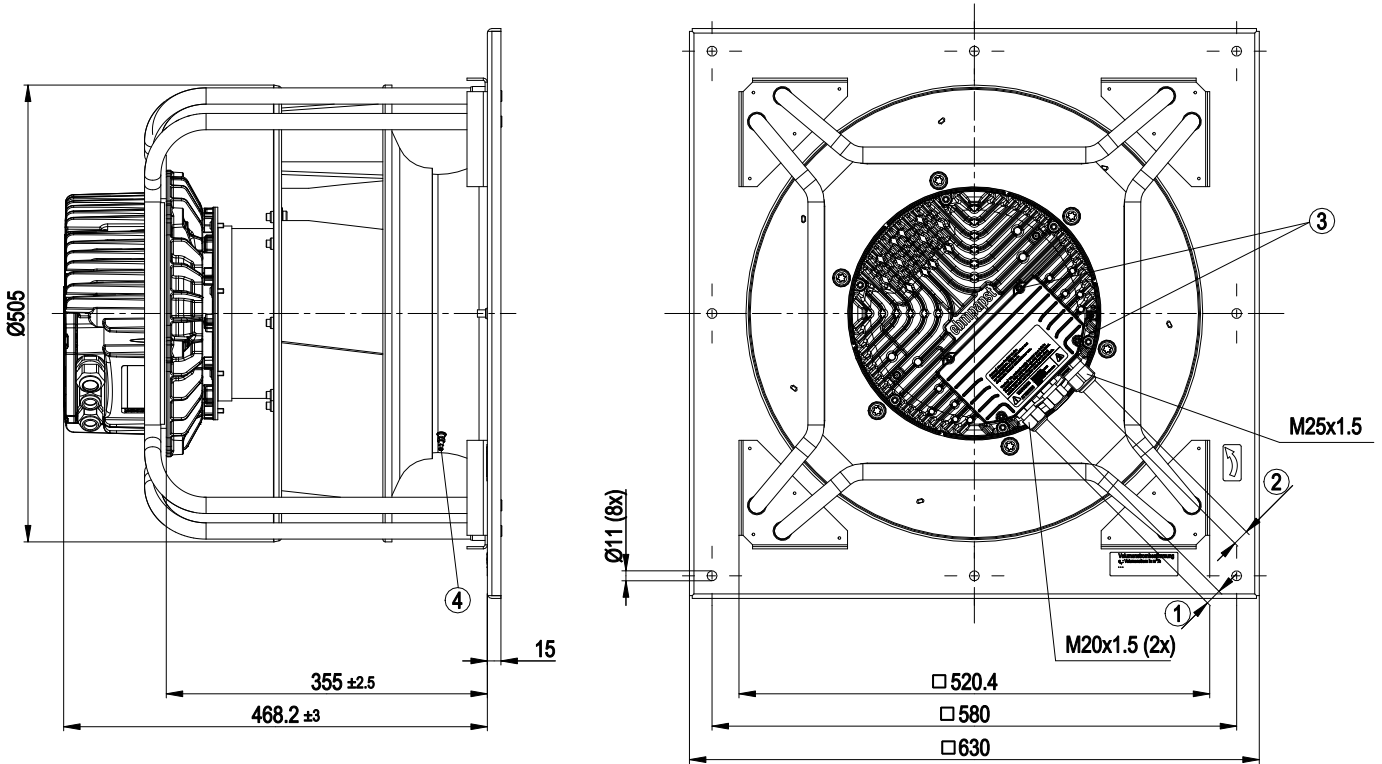

- | | |
|---|--|
| 1 | Cable diameter min. 4 mm, max. 10 mm, tightening torque 4±0.6 Nm |
| 2 | Cable diameter min. 9 mm, max. 16 mm, tightening torque 6±0.9 Nm |
| 3 | Inlet nozzle with pressure tap (k-factor: 240) |
| 4 | Tightening torque 3.5±0.5 Nm |



EC centrifugal module - RadiPac

backward curved, single inlet

with support bracket

Connection screen

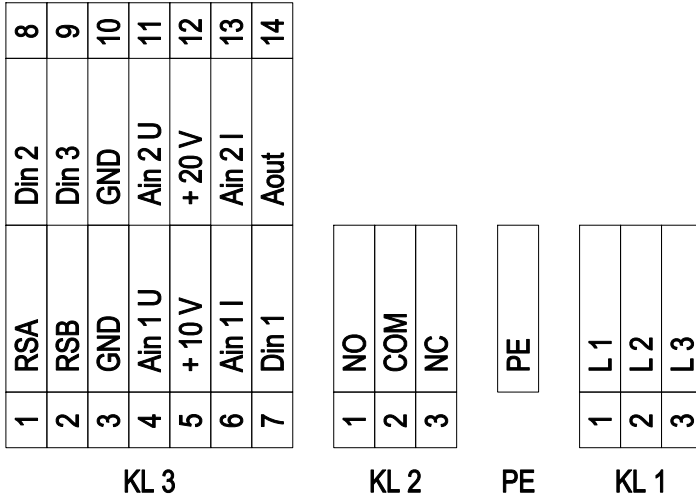

No.	Conn.	Designation	Function / assignment
KL 1	1	L1	Mains supply connection, supply voltage 3~380-480 VAC; 50/60 Hz
KL 1	2	L2	Mains supply connection, supply voltage 3~380-480 VAC; 50/60 Hz
KL 1	3	L3	Mains supply connection, supply voltage 3~380-480 VAC; 50/60 Hz
PE		PE	Earth connection, PE connection
KL 2	1	NO	Status relay, floating status contact; normally open; close with error
KL2	2	COM	Status relay; floating status contact; changeover contact; common connection; contact rating 250 VAC / max. 2 A (AC1) / min. 10 mA
KL2	3	NC	Status relay, floating status contact; break with error
KL 3	1	RSA	Bus connection RS-485, RSA, MODBUS RTU; SELV
KL 3	2	RSB	Bus connection RS-485, RSB, MODBUS RTU; SELV
KL 3	3 / 10	GND	Signal ground for control interface; SELV
KL 3	4	Ain1 U	Analogue input 1, set value: 0-10 V, Ri = 100 kΩ, parametrisable curve, only usable as alternative to input Ain1; SELV
KL 3	5	+ 10 V	Fixed voltage output 10 VDC, +10 V ±3%, max. 10 mA, short-circuit-proof, power supply for external devices (e.g. potentiometer), SELV
KL 3	6	Ain1 I	Analogue input 1, set value: 4-20 mA; Ri = 100 Ω, parametrisable curve, only usable as alternative to input Ain1 U; SELV
KL 3	7	Din1	Digital input 1: enabling of electronics, enabling: open pin or applied voltage 5-50 VDC disabling: bridge to GND or applied voltage <1 VDC reset function: triggers software reset after a level change to <1 VDC; SELV
KL 3	8	Din2	Digital input 2: parameter set switch 1/2, according to EEPROM setting, the valid/used parameter set can be selected via bus or via digital input DIN2. Parameter set 1: open pin or applied voltage 5-50 VDC Parameter set 2: bridge to GND or applied voltage <1 VDC; SELV
KL 3	9	Din3	Digital input 3: controller function of integrated controller, according to EEPROM setting, the controller function of the integrated controller is normally/inversely selectable per bus or per digital input normal: open pin or applied voltage 5-50 VDC inverse: bridge to GND or applied voltage <1 VDC; SELV
KL 3	11	Ain2 U	Analogue input 2, actual value: 0-10 V, Ri = 100 kΩ, parametrisable curve, only usable as alternative to input Ain2; SELV
KL 3	12	+ 20 V	Fixed voltage output 20 VDC, +20 V ±25/-10%, max. 50 mA, short-circuit-proof, power supply for external devices (e.g. sensors); SELV



EC centrifugal module - RadiPac

backward curved, single inlet

with support bracket

No.	Conn.	Designation	Function / assignment
KL 3	13	Ain2 I	Analogue input 2, actual value: 4-20 mA, Ri = 100 Ω , parametrisable curve, only usable as alternative to input Ain2 U; SELV
KL 3	14	Aout	Analogue output 0-10 VDC, max. 5 mA, output of the current motor level control coefficient / motor speed parametrisable curve; SELV



EC centrifugal module - RadiPac

backward curved, single inlet
with support bracket

Charts: Air flow 50 Hz

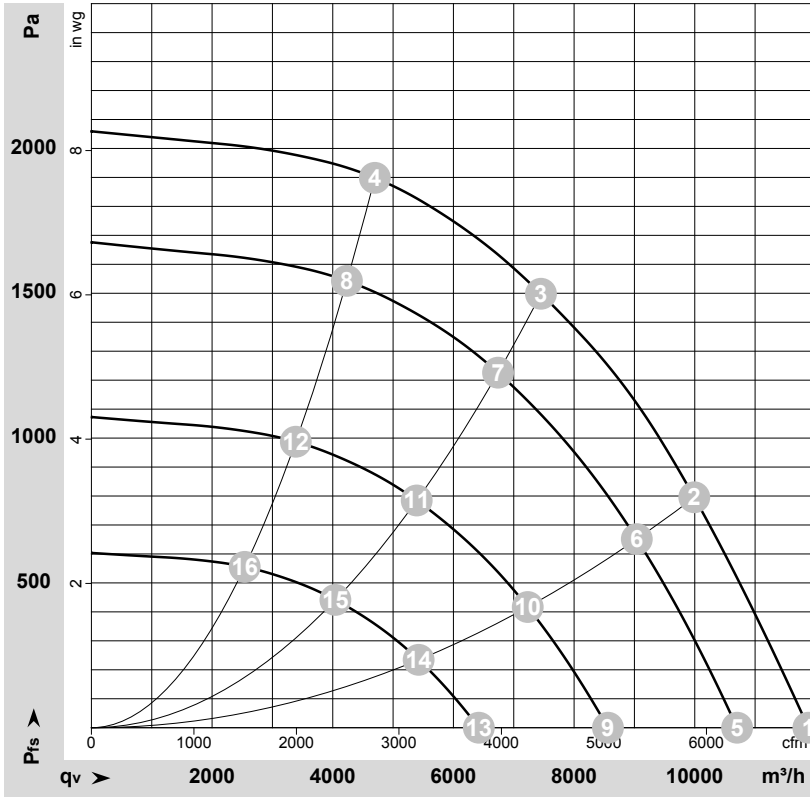

$\rho = 1.15 \text{ kg/m}^3 \pm 2 \%$

Measurement: LU-173540-1

Air performance measured as per ISO 5801 Installation category A. For detailed information on the measuring set-up, please contact ebmpapst. Suction-side noise levels: L_{wA} measured as per ISO 13347 / L_{pA} measured with 1m distance to fan axis. The values given are valid under the measuring conditions mentioned above and may vary according to the actual installation situation. With any deviation from the standard set-up, the specific values have to be checked and reviewed with the unit installed.

Measured values

	U	f	n	P _{ed}	I	LpA _{in}	LwA _{in}	LwA _{out}	q _v	P _{fs}	q _v	P _{fs}
	V	Hz	min ⁻¹	W	A	dB(A)	dB(A)	dB(A)	m ³ /h	Pa	cfm	inH ₂ O
1	400	50	2750	3352	5.24	91	99	106	11885	0	6995	0.00
2	400	50	2750	4388	6.79	87	93	100	9990	800	5880	3.21
3	400	50	2750	5050	7.95	81	89	97	7450	1500	4385	6.02
4	400	50	2750	4815	7.40	87	97	99	4695	1900	2765	7.63
5	400	50	2500	2449	3.82	88	97	103	10700	0	6300	0.00
6	400	50	2500	3256	5.03	84	91	97	9040	661	5320	2.65
7	400	50	2500	3752	5.76	79	86	94	6740	1233	3965	4.95
8	400	50	2500	3525	5.42	85	94	97	4235	1554	2495	6.24
9	400	50	2000	1254	1.96	83	91	97	8560	0	5040	0.00
10	400	50	2000	1667	2.58	79	85	92	7230	423	4255	1.70
11	400	50	2000	1921	2.95	73	81	88	5390	789	3175	3.17
12	400	50	2000	1805	2.77	79	89	91	3390	994	1995	3.99
13	400	50	1500	529	0.83	75	84	90	6420	0	3780	0.00
14	400	50	1500	703	1.09	71	78	84	5425	238	3190	0.96
15	400	50	1500	810	1.24	66	73	81	4045	444	2380	1.78
16	400	50	1500	761	1.17	72	82	84	2540	559	1495	2.24

U = Supply voltage · f = Frequency · n = Speed (rpm) · P_{ed} = Power input · I = Current draw · LpA_{in} = Sound pressure level inlet side · LwA_{in} = Sound power level inlet side · LwA_{out} = Sound power level outlet side
q_v = Air flow · P_{fs} = Pressure increase

