

EC centrifugal module

backward curved, single inlet

with support plate

K3G450-AS06-04 ebmpapst Datasheet

sales@fansco.com

www.fansco.com

Limited partnership · Headquarters Mulfingen
County court Stuttgart · HRA 590344

General partner Elektrobau Mulfingen GmbH · Headquarters Mulfingen
County court Stuttgart · HRB 590142



Nominal data

Type	K3G450-AS06-04	
Motor	M3G150-FF	
Phase		3~
Nominal voltage	VAC	400
Frequency	Hz	50/60
Type of data definition		ml
State		prelim.
Speed	min ⁻¹	2150
Power input	W	2900
Current draw	A	4.5
Min. ambient temperature	°C	-25
Max. ambient temperature	°C	+50

ml = max. load · me = max. efficiency · fa = running at free air · cs = customer specs · cu = customer unit
Subject to alterations

Data according to ErP directive

Installation category	A
Efficiency category	Static
Variable speed drive	Yes
Specific ratio*	1.01

* Specific ratio = $1 + p_{fs} / 100\,000\text{ Pa}$

	Actual	Request 2013	Request 2015
Overall efficiency η_{es}	58.7	52.3	56.3
Efficiency grade N	64.4	58	62
Power input P_{ed}	kW	2.86	
Air flow q_v	m ³ /h	6420	
Pressure increase p_{fs}	Pa	894	
Speed n	min ⁻¹	2130	

Data established at point of optimum efficiency



Technical features

Mass	34.8 kg
Size	450 mm
Surface of rotor	Coated in black
Material of electronics housing	Die-cast aluminium
Material of impeller	Aluminium sheet
Material of mounting plate	Sheet steel, hot-dip galvanised
Material of distancing profiles	Aluminium
Material of inlet nozzle	Sheet steel, hot-dip galvanised
Number of blades	7
Direction of rotation	Clockwise, seen on rotor
Type of protection	IP 54
Insulation class	"F"
Humidity class	F4-1
Max. permissible ambient motor temp. (transp./ storage)	+80 °C
Min. permissible ambient motor temp. (transp./storage)	-40 °C
Mounting position	Shaft horizontal or rotor on bottom; rotor on top on request
Condensate discharge holes	Rotor-side
Operation mode	S1
Motor bearing	Ball bearing
Technical features	<ul style="list-style-type: none"> - PFC, passive - Control input 0-10 VDC / PWM - Over-temperature protected electronics / motor - Alarm relay - Integrated PID controller - Input for sensor 0-10 V or 4-20 mA - Output for slave 0-10 V - RS485 ebmBUS - Motor current limit - Soft start - Line undervoltage / phase failure detection - Output 10 VDC, max. 10 mA - Output 20 VDC, max. 50 mA
EMC interference immunity	Acc. to EN 61000-6-2 (industrial environment)
EMC interference emission	Acc. to EN 61000-6-3 (household environment)
Touch current acc. IEC 60990 (measuring network Fig. 4, TN system)	<= 3.5 mA
Electrical leads	Via terminal box
Motor protection	Reverse polarity and locked-rotor protection
Protection class	I (if protective earth is connected by customer)
Product conforming to standard	EN 61800-5-1; CE
Approval	VDE; GOST; UL 1004-1; CSA C22.2 Nr.77

EC centrifugal module

backward curved, single inlet
with support plate

Product drawing

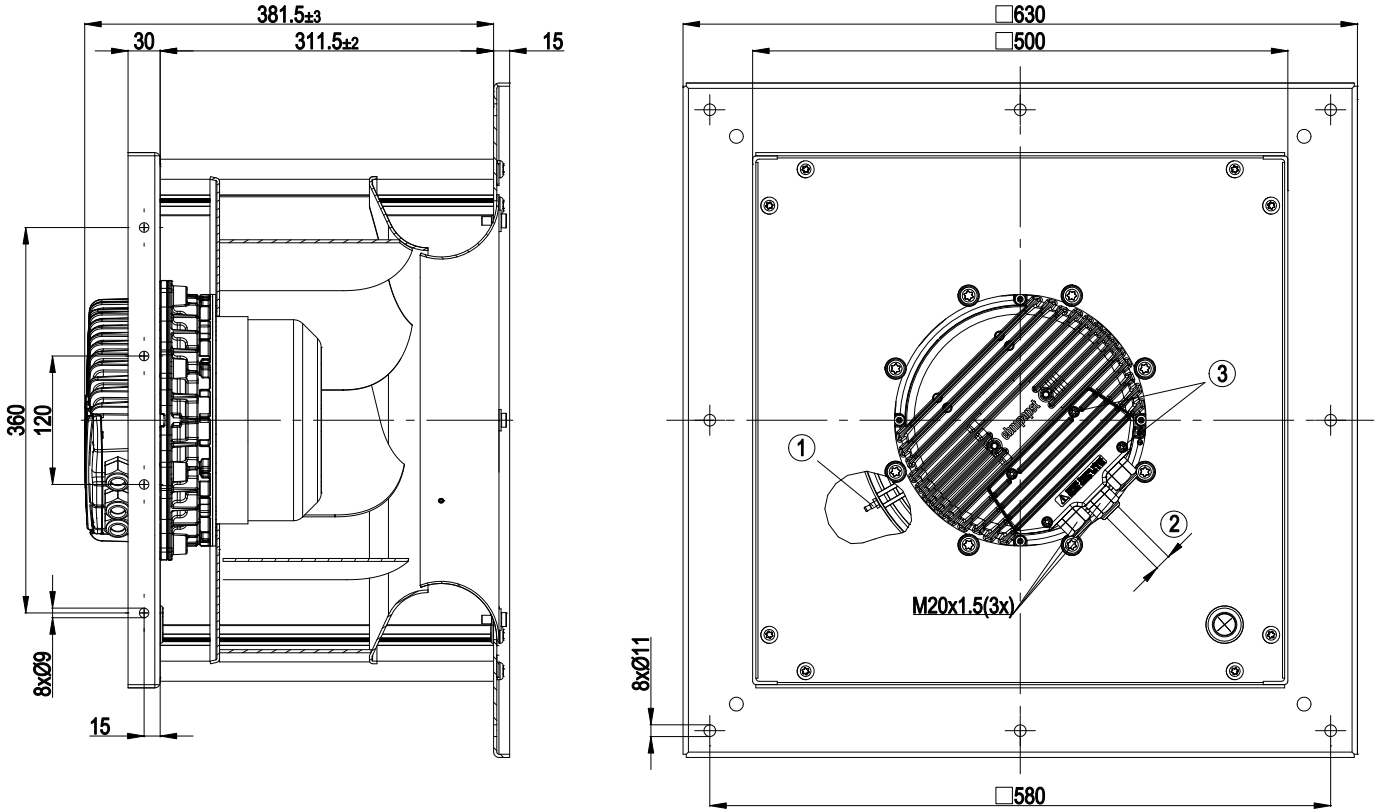

1	Inlet nozzle with bleeder connection for pressure relief (k-factor: 225)
2	Cable diameter: min. 4 mm, max. 10 mm; tightening torque: 4±0.6 Nm
3	Tightening torque 3.5±0.5 Nm



EC centrifugal module

backward curved, single inlet
with support plate

Connection screen

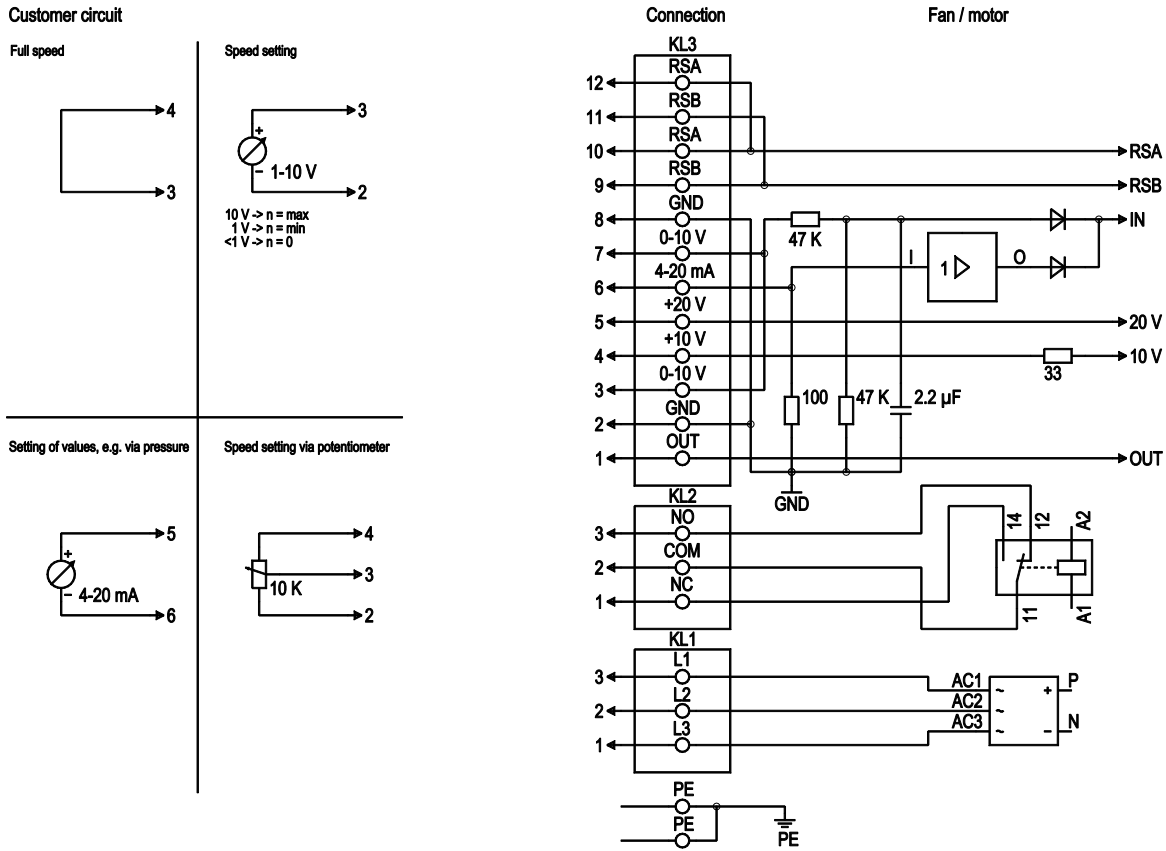

No.	Pin	Signal	Function / assignment
PE		PE	Protective earth connection
KL1	1, 2, 3	L1, L2, L3	Supply voltage, 50/60 Hz
KL2	1	NC	Floating status message contact, normally closed connection
KL2	2	COM	Floating status message contact, changeover contact, common connection (2 A, max. 250 VAC, min. 10 mA, AC1)
KL2	3	NO	Floating status message contact, normally open connection
KL3	1	OUT	Analog output, 0-10 VDC, max. 3 mA, SELV, output of the current level control coefficient: 1 V equates to 10 % level control coefficient. 10 V equate to 100 % level control coefficient.
KL3	2, 8	GND	Reference mass for control interface, SELV
KL3	3, 7	0-10 V	Use control / actual value input 0-10 VDC, impedance 100 kΩ only as alternative to 4-20 mA input, SELV
KL3	4	+10 V	Voltage output 10 VDC (+/-3 %), max. 10 mA, supply voltage for ext. devices (e.g. potentiometers), SELV
KL3	5	+20 V	Voltage output 20 VDC (+25 %/-10 %), max. 50 mA, supply voltage for ext. devices (e.g. sensors), SELV
KL3	6	4-20 mA	Use control / actual value input 4-20 mA, impedance 100 Ω, only as alternative to 0-10 V input, SELV
KL3	9, 11	RSB	RS485 interface for ebmBus, RSB, SELV
KL3	10, 12	RSA	RS485 interface for ebmBus, RSA, SELV



Charts: Air flow 50 Hz

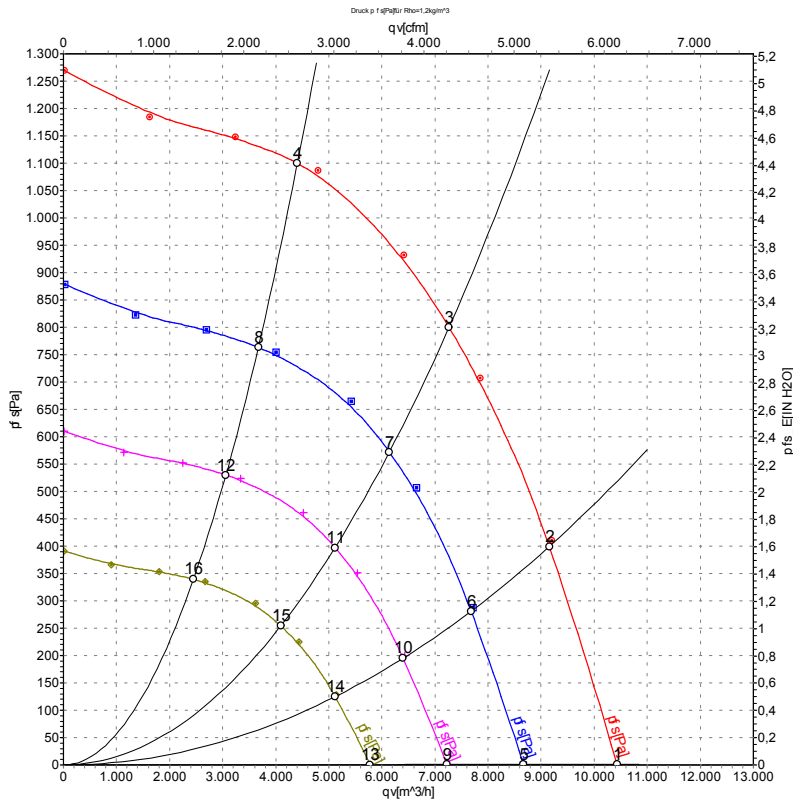

Measurement: LU-100849

Air performance measured as per ISO 5801 Installation category A. For detailed information on the measuring set-up, please contact ebm-papst. Suction-side noise levels: LwA measured as per ISO 13347 / LpA measured with 1m distance to fan axis. The values given are valid under the measuring conditions mentioned above and may vary according to the actual installation situation. With any deviation from the standard set-up, the specific values have to be checked and reviewed with the unit installed.

Measured values

	U	f	n	P _{ed}	I	LpA _{in}	LwA _{in}	LwA _{out}	qv	p _{fs}
	V	Hz	min ⁻¹	W	A	dB(A)	dB(A)	dB(A)	m ³ /h	Pa
1	400	50	2150	2142	3.26	91	96	101	10430	0
2	400	50	2150	2696	4.13	92	96	99	9155	400
3	400	50	2150	2900	4.50	81	88	94	7265	800
4	400	50	2150	2594	3.94	81	89	95	4410	1100
5	400	50	1800	1230	1.87	87	92	97	8670	0
6	400	50	1800	1590	2.44	89	93	96	7680	296
7	400	50	1800	1738	2.67	77	85	90	6140	572
8	400	50	1800	1499	2.28	77	85	91	3675	765
9	400	50	1500	712	1.08	83	89	93	7225	0
10	400	50	1500	920	1.41	85	89	92	6400	205
11	400	50	1500	1006	1.54	73	81	86	5120	397
12	400	50	1500	868	1.32	73	81	87	3060	531
13	400	50	1200	364	0.55	78	84	88	5780	0
14	400	50	1200	471	0.72	80	84	87	5120	132
15	400	50	1200	515	0.79	69	76	82	4095	254
16	400	50	1200	444	0.67	68	76	82	2450	340

U = Supply voltage · f = Frequency · n = Speed · P_{ed} = Power input · I = Current draw · LpA_{in} = Sound pressure level inlet side · LwA_{in} = Sound power level inlet side · LwA_{out} = Sound power level outlet side
 qv = Air flow · p_{fs} = Pressure increase

