

backward curved, single inlet

with support bracket

K3G400-PA27-75 ebmpapst Datasheet

sales@fansco.com

www.fansco.com

Limited partnership · Headquarters Muldingen
County court Stuttgart · HRA 590344

General partner Elektrobau Muldingen GmbH · Headquarters Muldingen
County court Stuttgart · HRB 590142

Nominal data

Type	K3G400-PA27-75	
Motor	M3G150-FF	
Phase		3~
Nominal voltage	VAC	400
Nominal voltage range	VAC	380 .. 480
Frequency	Hz	50/60
Type of data definition		ml
Speed (rpm)	min ⁻¹	2750
Power input	W	3350
Current draw	A	5.2
Min. ambient temperature	°C	-25
Max. ambient temperature	°C	60

ml = Max. load · me = Max. efficiency · fa = Running at free air · cs = Customer specs · cu = Customer unit
Subject to alterations

Data according to ErP directive

		Actual	Request 2015			
01 Overall efficiency η_{es}	%	69.4	57	09 Power input P_{ed}	kW	3.31
02 Measurement category		A		09 Air flow q_v	m ³ /h	6755
03 Efficiency category		Static		09 Pressure increase p_{fs}	Pa	1175
04 Efficiency grade N		74.4	62	10 Speed (rpm) n	min ⁻¹	2750
05 Variable speed drive		Yes		11 Specific ratio [*]		1.01

Data definition with optimum efficiency.

The ErP data is determined using a motor-impeller combination in a standardised measurement configuration.

^{*} Specific ratio = $1 + p_{fs} / 100\,000\text{ Pa}$

LU-176800



Technical features

Mass	31.5 kg
Size	400 mm
Surface of rotor	Coated in black
Material of electronics housing	Die-cast aluminium
Material of impeller	Aluminium sheet
Material of mounting plate	Sheet steel, galvanised
Material of support bracket	Steel, coated in black
Material of inlet nozzle	Sheet steel, galvanised
Number of blades	5
Direction of rotation	Clockwise, seen on rotor
Type of protection	IP 55
Insulation class	"F"
Humidity (F)/environmental protection class (H)	H1
Max. permissible ambient motor temp. (transp./ storage)	+80 °C
Min. permissible ambient motor temp. (transp./storage)	-40 °C
Mounting position	Refer to product drawing
Condensate discharge holes	Rotor-side
Operation mode	S1
Motor bearing	Ball bearing
Technical features	<ul style="list-style-type: none"> - Output 10 VDC, max. 10 mA - Operation and alarm display - External 24 V input (programming) - External release input - Alarm relay - Integrated PID controller - Motor current limit - PFC, passive - RS485 MODBUS RTU - Soft start - Control input 0-10 VDC / PWM - Control interface with SELV potential safely disconnected from the mains - Over-temperature protected electronics / motor - Line undervoltage / phase failure detection
EMC interference immunity	Acc. to EN 61000-6-2 (industrial environment)
EMC interference emission	Acc. to EN 61000-6-3 (household environment), except EN 61000-3-2 for professionally used devices with a total rated power greater than 1 kW
Touch current acc. IEC 60990 (measuring network Fig. 4, TN system)	<= 3.5 mA
Electrical leads	Via terminal box
Motor protection	Reverse polarity and locked-rotor protection
Protection class	I (if protective earth is connected by customer)
Product conforming to standard	EN 61800-5-1; CE
Approval	EAC

EC centrifugal module - RadiPac

backward curved, single inlet
with support bracket

Product drawing

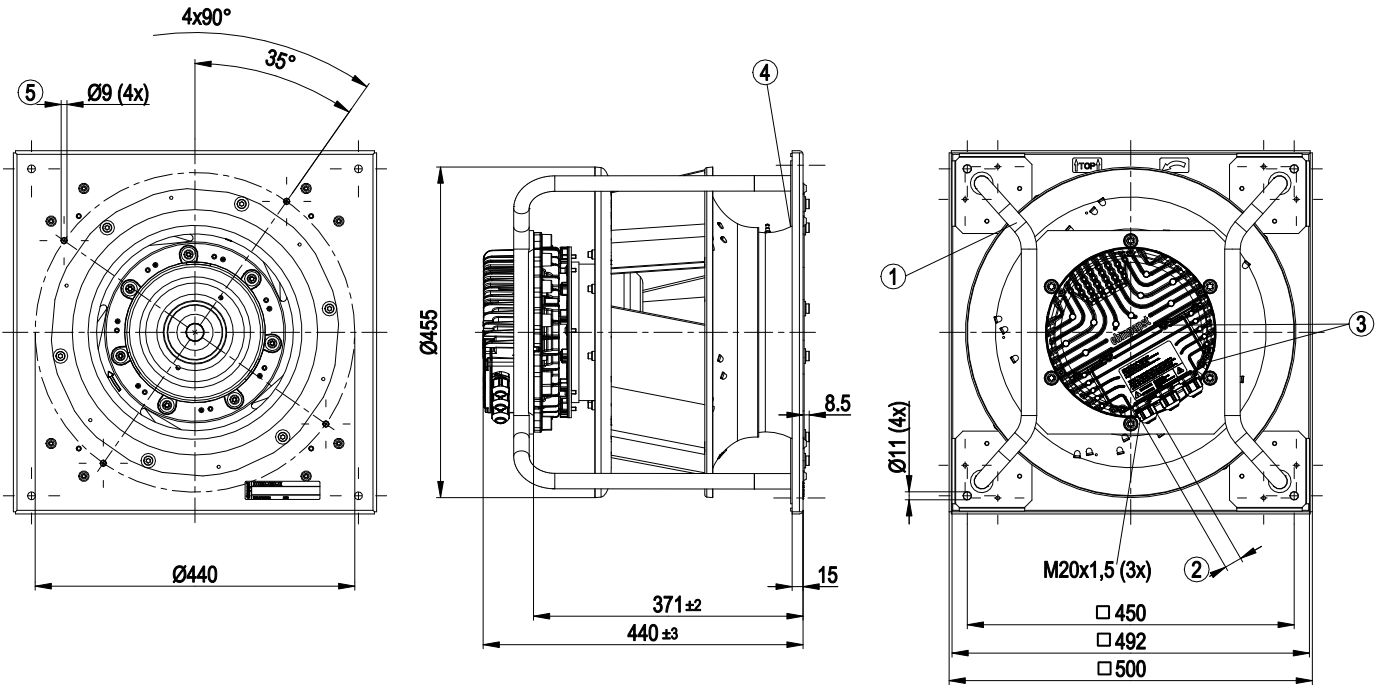

1	Installation position: Shaft horizontal (install the support struts only vertically as shown in the illustration!) or rotor on bottom; rotor on top on request
2	Cable diameter min. 4 mm, max. 10 mm, tightening torque 4 ± 0.6 Nm
3	Tightening torque 3.5 ± 0.5 Nm
4	Inlet nozzle with pressure tap (k-factor: 188)
5	Mounting holes for FlowGrid



EC centrifugal module - RadiPac

backward curved, single inlet
with support bracket

Connection screen

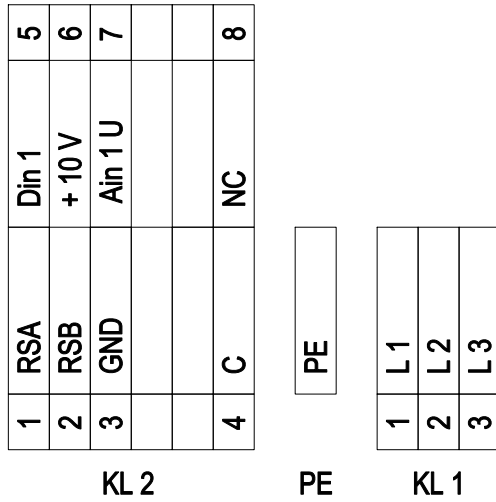

No.	Conn.	Designation	Function / assignment
KL 1	1	L1	Mains supply connection, supply voltage 3~380-480 VAC; 50/60 Hz
KL 1	2	L2	Mains supply connection, supply voltage 3~380-480 VAC; 50/60 Hz
KL 1	3	L3	Mains supply connection, supply voltage 3~380-480 VAC; 50/60 Hz
PE		PE	Earth connection, PE connection
KL 2	1	RSA	Bus connection RS-485, RSA, MODBUS RTU; SELV
KL 2	2	RSB	Bus connection RS-485, RSB, MODBUS RTU; SELV
KL 2	3	GND	Signal ground for control interface; SELV
KL2	4	C	Status relay; floating status contact; changeover contact; common connection; contact rating 250 VAC / 2 A (AC1)
KL 2	5	Din1	Digital input 1 enabling of electronics, enabling: open pin or applied voltage 5-50 VDC disabling: bridge to GND or applied voltage <1 VDC reset function: triggers software reset after a level change to <1 V; SELV
KL 2	6	+ 10 V	Fixed voltage output 10 VDC; +10 V -3 %, max. 10 mA, short-circuit-proof, power supply for external devices (e.g. potentiometer); SELV Alternative: +24 VDC input for parametrisation via MODBUS without mains power
KL 2	7	Ain1 U	Analogue input 1 (set value) 0-10 V, Ri=100 kΩ, parametrisable curve; SELV
KL2	8	NC	Status relay, floating status contact; break for failure



Charts: Air flow 50 Hz

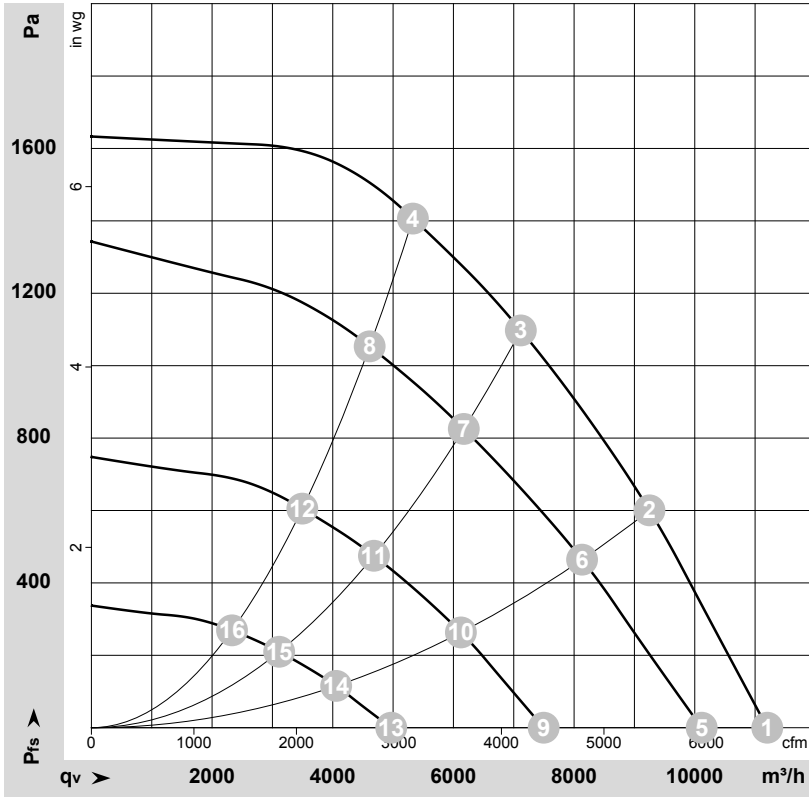

$\rho = 1.15 \text{ kg/m}^3 \pm 2 \%$

Measurement: LU-176800-1

Air performance measured as per ISO 5801 Installation category A. For detailed information on the measuring set-up, please contact ebmpapst. Suction-side noise levels: LwA measured as per ISO 13347 / LpA measured with 1m distance to fan axis. The values given are valid under the measuring conditions mentioned above and may vary according to the actual installation situation. With any deviation from the standard set-up, the specific values have to be checked and reviewed with the unit installed.

Measured values

	U	f	n	P _{ed}	I	LpA _{in}	LwA _{in}	LwA _{out}	q _v	P _{fs}	q _v	P _{fs}
	V	Hz	min ⁻¹	W	A	dB(A)	dB(A)	dB(A)	m ³ /h	Pa	cfm	inH ₂ O
1	400	50	2750	1846	2.90	93	100	101	11200	0	6595	0.00
2	400	50	2750	2827	4.35	83	90	94	9250	600	5445	2.41
3	400	50	2750	3289	5.04	78	85	93	7115	1100	4190	4.42
4	400	50	2750	3350	5.20	79	86	93	5330	1400	3135	5.62
5	400	50	2490	1389	2.24	89	96	97	10115	0	5955	0.00
6	400	50	2415	1940	3.04	80	87	91	8130	469	4785	1.88
7	400	50	2385	2162	3.37	74	82	89	6170	826	3635	3.32
8	400	50	2380	2179	3.39	76	83	89	4610	1054	2715	4.23
9	400	50	1850	619	1.20	80	87	89	7495	0	4410	0.00
10	400	50	1820	869	1.52	71	80	84	6125	265	3605	1.06
11	400	50	1805	977	1.66	68	77	82	4680	475	2755	1.91
12	400	50	1805	982	1.67	69	78	83	3495	605	2060	2.43
13	400	50	1240	227	0.61	69	77	78	4970	0	2925	0.00
14	400	50	1215	298	0.73	60	69	73	4055	117	2390	0.47
15	400	50	1205	330	0.78	58	66	71	3110	210	1830	0.84
16	400	50	1205	332	0.79	59	66	72	2330	269	1370	1.08

U = Supply voltage · f = Frequency · n = Speed (rpm) · P_{ed} = Power input · I = Current draw · LpA_{in} = Sound pressure level inlet side · LwA_{in} = Sound power level inlet side · LwA_{out} = Sound power level outlet side
 q_v = Air flow · P_{fs} = Pressure increase

