

# EC centrifugal module - RadiPac

backward curved, single inlet  
with support bracket



K3G400-AQ23-35 ebmpapst Datasheet  
sales@fansco.com  
www.fansco.com

## Nominal data

Type	K3G400-AQ23-35	
Motor	M3G150-FF	
Phase		3~
Nominal voltage	VAC	400
Nominal voltage range	VAC	380 .. 480
Frequency	Hz	50/60
Type of data definition		ml
Speed	min <sup>-1</sup>	2550
Power input	W	3000
Current draw	A	4.6
Min. ambient temperature	°C	-25
Max. ambient temperature	°C	60

ml = Max. load · me = Max. efficiency · fa = Running at free air · cs = Customer specs · cu = Customer unit  
Subject to alterations

## Data according to ErP directive

Installation category	A
Efficiency category	Static
Variable speed drive	Yes
Specific ratio*	1.01

\* Specific ratio =  $1 + p_{fs} / 100\,000\text{ Pa}$

		Actual	Request 2013	Request 2015
Overall efficiency $\eta_{es}$	%	62.8	52.4	56.4
Efficiency grade N		68.4	58	62
Power input $P_{ed}$	kW	2.95		
Air flow $q_v$	m <sup>3</sup> /h	5960		
Pressure increase $p_{fs}$	Pa	1064		
Speed n	min <sup>-1</sup>	2540		

Data definition with optimum efficiency. LU-121371  
The ErP data is determined using a motor-impeller combination in a standardised measurement configuration.



### Technical features

Mass	33 kg
Size	400 mm
Surface of rotor	Coated in black
Material of electronics housing	Die-cast aluminium, coated in black
Material of impeller	Aluminium sheet, white plastic-coated
Material of mounting plate	Sheet steel, hot-galvanised and coated in white
Material of support bracket	Steel, galvanised and coated in black
Material of inlet nozzle	Sheet steel, hot-galvanised and coated in white
Number of blades	7
Direction of rotation	Clockwise, seen on rotor
Type of protection	IP 54
Insulation class	"F"
Humidity class	F5
Max. permissible ambient motor temp. (transp./ storage)	+80 °C
Min. permissible ambient motor temp. (transp./storage)	-40 °C
Mounting position	Refer to product drawing
Condensate discharge holes	Rotor-side
Operation mode	S1
Motor bearing	Ball bearing
Technical features	<ul style="list-style-type: none"> <li>- Output 10 VDC, max. 10 mA</li> <li>- Output 20 VDC, max. 50 mA</li> <li>- Output for slave 0-10 V</li> <li>- Operation and alarm display</li> <li>- Input for sensor 0-10 V or 4-20 mA</li> <li>- External 24 V input (programming)</li> <li>- External release input</li> <li>- Alarm relay</li> <li>- Integrated PID controller</li> <li>- Motor current limit</li> <li>- PFC, passive</li> <li>- RS485 MODBUS RTU</li> <li>- Soft start</li> <li>- Control input 0-10 VDC / PWM</li> <li>- Control interface with SELV potential safely disconnected from the mains</li> <li>- Over-temperature protected electronics / motor</li> <li>- Line undervoltage / phase failure detection</li> </ul>
EMC interference immunity	Acc. to EN 61000-6-2 (industrial environment)
EMC interference emission	Acc. to EN 61000-6-3 (household environment)
Touch current acc. IEC 60990 (measuring network Fig. 4, TN system)	<= 3.5 mA
Electrical leads	Via terminal box
Motor protection	Reverse polarity and locked-rotor protection
Protection class	I (if protective earth is connected by customer)
Product conforming to standard	EN 61800-5-1; CE
Approval	C22.2 Nr.77 + CAN/CSA-E60730-1; EAC; UL 1004-7 + 60730

# EC centrifugal module - RadiPac

backward curved, single inlet  
with support bracket

## Product drawing

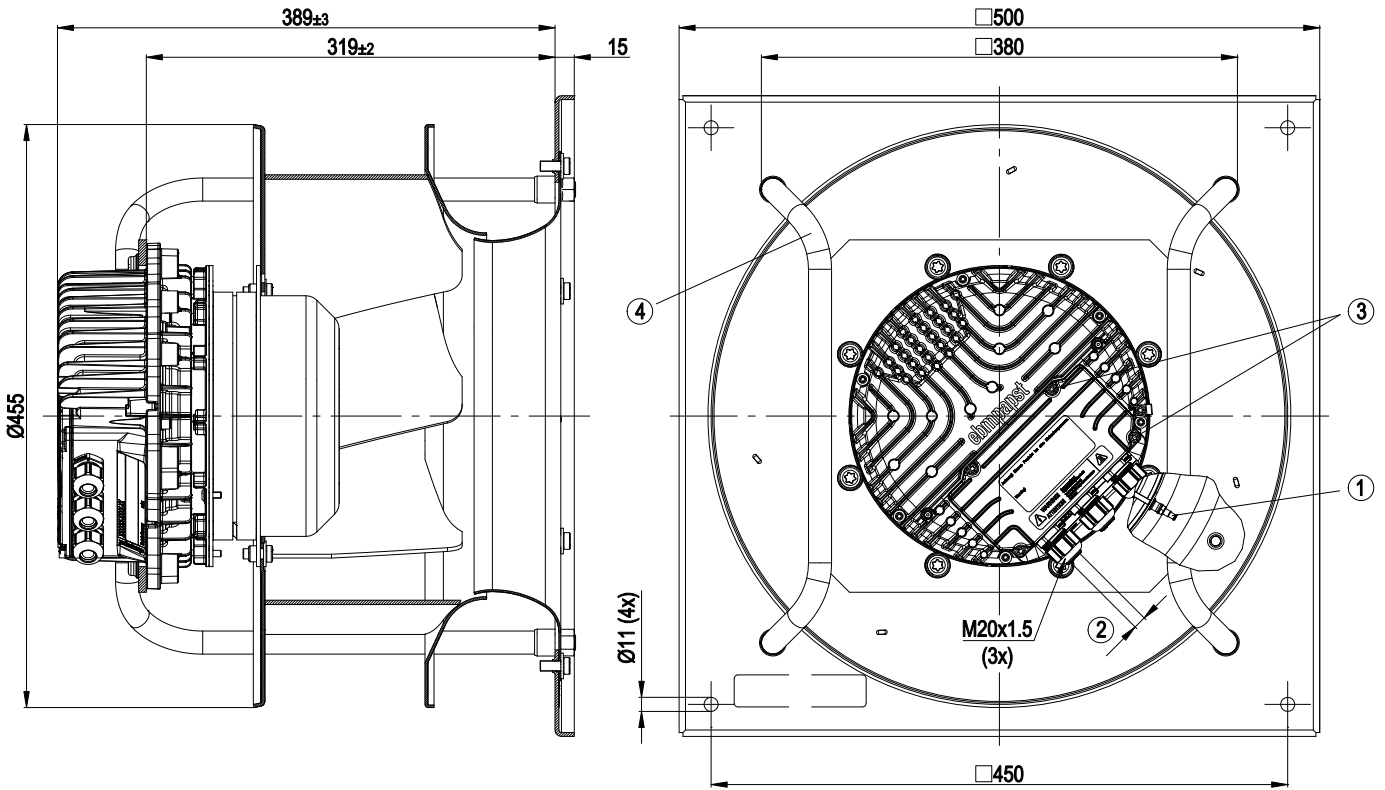

1	Inlet nozzle with bleeder connection for pressure relief (k-factor: 188)
2	Cable diameter: min. 4 mm, max. 10 mm; tightening torque: 4±0.6 Nm
3	Tightening torque 3.5±0.5 Nm
4	Mounting position: shaft horizontal (install the support struts only vertically as shown in the view!) or rotor on bottom; rotor on top on request



# EC centrifugal module - RadiPac

backward curved, single inlet

with support bracket

## Connection screen

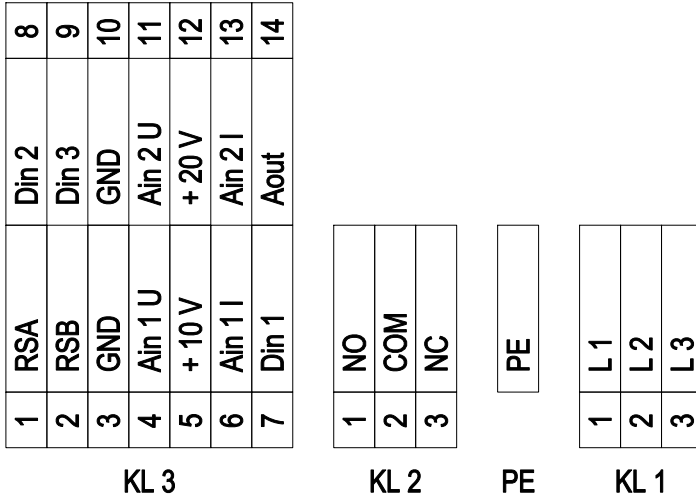

No.	Conn.	Designation	Function / assignment
KL 1	1	L1	Mains supply connection, supply voltage 3~380-480 VAC; 50/60 Hz
KL 1	2	L2	Mains supply connection, supply voltage 3~380-480 VAC; 50/60 Hz
KL 1	3	L3	Mains supply connection, supply voltage 3~380-480 VAC; 50/60 Hz
PE		PE	Earth connection, PE connection
KL 2	1	NO	Status relay, floating status contact; normally open; close with error
KL2	2	COM	Status relay; floating status contact; changeover contact; common connection; contact rating 250 VAC / max. 2 A (AC1) / min. 10 mA
KL2	3	NC	Status relay, floating status contact; break with error
KL 3	1	RSA	Bus connection RS-485, RSA, MODBUS RTU; SELV
KL 3	2	RSB	Bus connection RS-485, RSB, MODBUS RTU; SELV
KL 3	3 / 10	GND	Signal ground for control interface; SELV
KL 3	4	Ain1 U	Analogue input 1, set value: 0-10 V, Ri = 100 kΩ, parametrisable curve, only usable as alternative to input Ain1; SELV
KL 3	5	+ 10 V	Fixed voltage output 10 VDC, +10 V ±3%, max. 10 mA, short-circuit-proof, power supply for external devices (e.g. potentiometer), SELV
KL 3	6	Ain1 I	Analogue input 1, set value: 4-20 mA; Ri = 100 Ω, parametrisable curve, only usable as alternative to input Ain1 U; SELV
KL 3	7	Din1	Digital input 1: enabling of electronics, enabling: open pin or applied voltage 5-50 VDC disabling: bridge to GND or applied voltage <1 VDC reset function: triggers software reset after a level change to <1 VDC; SELV
KL 3	8	Din2	Digital input 2: parameter set switch 1/2, according to EEPROM setting, the valid/used parameter set can be selected via bus or via digital input DIN2. Parameter set 1: open pin or applied voltage 5-50 VDC Parameter set 2: bridge to GND or applied voltage <1 VDC; SELV
KL 3	9	Din3	Digital input 3: controller function of integrated controller, according to EEPROM setting, the controller function of the integrated controller is normally/inversely selectable per bus or per digital input normal: open pin or applied voltage 5-50 VDC inverse: bridge to GND or applied voltage <1 VDC; SELV
KL 3	11	Ain2 U	Analogue input 2, actual value: 0-10 V, Ri = 100 kΩ, parametrisable curve, only usable as alternative to input Ain2; SELV
KL 3	12	+ 20 V	Fixed voltage output 20 VDC, +20 V ±25/-10%, max. 50 mA, short-circuit-proof, power supply for external devices (e.g. sensors); SELV



# EC centrifugal module - RadiPac

backward curved, single inlet

with support bracket

No.	Conn.	Designation	Function / assignment
KL 3	13	Ain2 I	Analogue input 2, actual value: 4-20 mA, $R_i = 100 \Omega$ , parametrisable curve, only usable as alternative to input Ain2 U; SELV
KL 3	14	Aout	Analogue output 0-10 VDC, max. 5 mA, output of the current motor level control coefficient / motor speed parametrisable curve; SELV



## Charts: Air flow 50 Hz

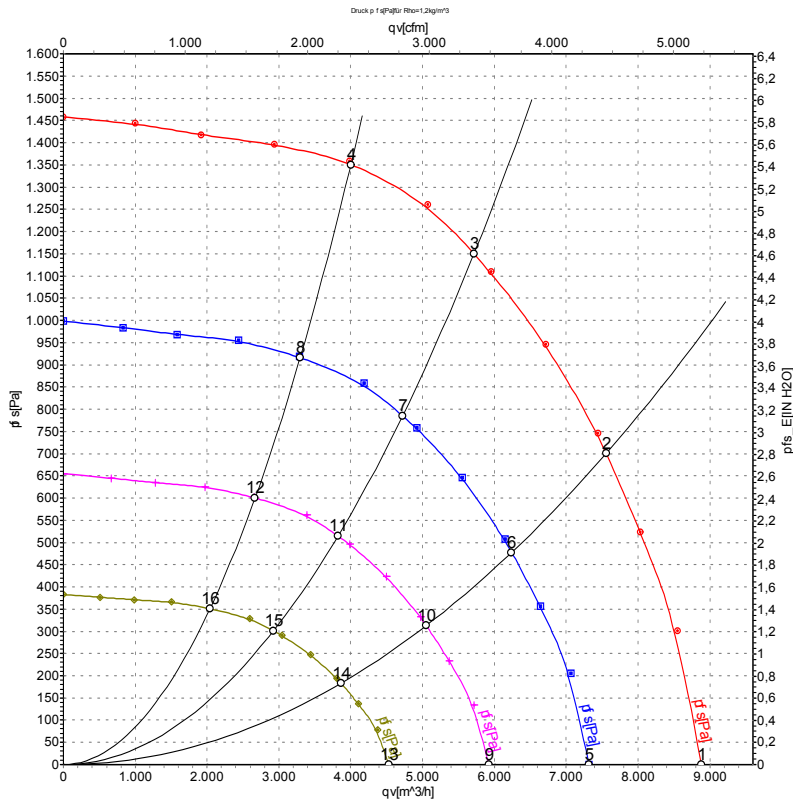

Measurement: LU-121371

Air performance measured as per ISO 5801 Installation category A. For detailed information on the measuring set-up, please contact ebmpapst. Suction-side noise levels: LwA measured as per ISO 13347 / LpA measured with 1m distance to fan axis. The values given are valid under the measuring conditions mentioned above and may vary according to the actual installation situation. With any deviation from the standard set-up, the specific values have to be checked and reviewed with the unit installed.

## Measured values

	U	f	n	P <sub>ed</sub>	I	LpA <sub>in</sub>	LwA <sub>in</sub>	LwA <sub>out</sub>	qv	p <sub>fs</sub>
	V	Hz	min <sup>-1</sup>	W	A	dB(A)	dB(A)	dB(A)	m <sup>3</sup> /h	Pa
1	400	50	2550	1972	3.02	86	93	99	8880	0
2	400	50	2550	2697	4.13	80	87	94	7555	700
3	400	50	2550	3000	4.60	78	85	92	5715	1150
4	400	50	2550	2792	4.27	80	88	94	4000	1350
5	400	50	2100	1103	1.69	82	89	95	7315	0
6	400	50	2100	1517	2.33	76	83	90	6240	479
7	400	50	2100	1668	2.56	74	81	88	4725	786
8	400	50	2100	1555	2.38	75	84	89	3295	918
9	400	50	1700	585	0.90	77	84	90	5920	0
10	400	50	1700	805	1.23	71	78	85	5050	314
11	400	50	1700	885	1.36	69	76	83	3825	515
12	400	50	1700	825	1.26	71	79	85	2665	602
13	400	50	1300	262	0.40	71	78	84	4530	0
14	400	50	1300	360	0.55	65	72	79	3865	184
15	400	50	1300	396	0.61	64	71	78	2925	301
16	400	50	1300	369	0.56	65	73	79	2040	352

U = Supply voltage · f = Frequency · n = Speed · P<sub>ed</sub> = Power input · I = Current draw · LpA<sub>in</sub> = Sound pressure level inlet side · LwA<sub>in</sub> = Sound power level inlet side · LwA<sub>out</sub> = Sound power level outlet side  
 qv = Air flow · p<sub>fs</sub> = Pressure increase

