

EC centrifugal module

backward curved, single inlet

with support plate

K3G400-AK11-H8 ebmpapst Datasheet

sales@fansco.com

www.fansco.com

Limited partnership · Headquarters Mulfingen
County court Stuttgart · HRA 590344

General partner Elektrobau Mulfingen GmbH · Headquarters Mulfingen
County court Stuttgart · HRB 590142

Nominal data

Type	K3G400-AK11-H8	
Motor	M3G084-DF	
Phase		1~
Nominal voltage	VAC	230
Nominal voltage range	VAC	200 .. 277
Frequency	Hz	50/60
Type of data definition		ml
Speed (rpm)	min ⁻¹	1750
Power input	W	380
Current draw	A	1.67
Min. ambient temperature	°C	-25
Max. ambient temperature	°C	60

ml = Max. load · me = Max. efficiency · fa = Running at free air · cs = Customer specs · cu = Customer unit
Subject to alterations

Data according to ErP directive

		Actual	Request 2015			
01 Overall efficiency η_{es}	%	59.9	47	09 Power input P_{ed}	kW	0.37
02 Measurement category		A		09 Air flow q_v	m ³ /h	1605
03 Efficiency category		Static		09 Pressure increase p_{fs}	Pa	455
04 Efficiency grade N		74.9	62	10 Speed (rpm) n	min ⁻¹	1755
05 Variable speed drive		Yes		11 Specific ratio*		1.00

Data definition with optimum efficiency.
The ErP data is determined using a motor-impeller combination in a standardised measurement configuration.

* Specific ratio = $1 + p_{fs} / 100\,000\text{ Pa}$

LU-166149



Technical features

Mass	8.9 kg
Size	400 mm
Surface of rotor	Coated in black
Material of electronics housing	Die-cast aluminium
Material of impeller	Aluminium sheet
Material of mounting plate	Aluminium sheet
Material of distancing profiles	Aluminium
Material of inlet nozzle	Aluminium sheet
Number of blades	6
Direction of rotation	Clockwise, seen on rotor
Type of protection	Motor IP 55, electronics IP 20
Insulation class	"F"
Humidity (F)/environmental protection class (H)	F3-1
Max. permissible ambient motor temp. (transp./ storage)	+80 °C
Min. permissible ambient motor temp. (transp./storage)	-40 °C
Mounting position	Shaft horizontal or rotor on top; rotor on bottom on request
Condensate discharge holes	None
Operation mode	S1
Motor bearing	Ball bearing
Technical features	<ul style="list-style-type: none"> - Output 10 VDC, max. 10 mA - Operation and alarm display - Operation and alarm display via LED - Alarm relay - Integrated PID controller - Output limit - Motor current limit - PFC, active - RS485 MODBUS RTU - Soft start - Control input 0-10 VDC / PWM - Control interface with SELV potential safely disconnected from the mains - Over-temperature protected electronics / motor - Line undervoltage / phase failure detection
EMC interference immunity	Acc. to EN 61000-6-2 (industrial environment)
EMC harmonics	Acc. to EN 61000-3-2/3
EMC interference emission	Acc. to EN 61000-6-3 (household environment)
Touch current acc. IEC 60990 (measuring network Fig. 4, TN system)	<= 3.5 mA
Electrical leads	With plug
Motor protection	Thermal overload protector (TOP) wired internally
Cable exit	Variable
Protection class	I (if protective earth is connected by customer)
Product conforming to standard	EN 61800-5-1; CE
Approval	UL 1004-7 + 60730; C22.2 Nr.77 + CAN/CSA-E60730-1

EC centrifugal module

backward curved, single inlet
with support plate

Product drawing

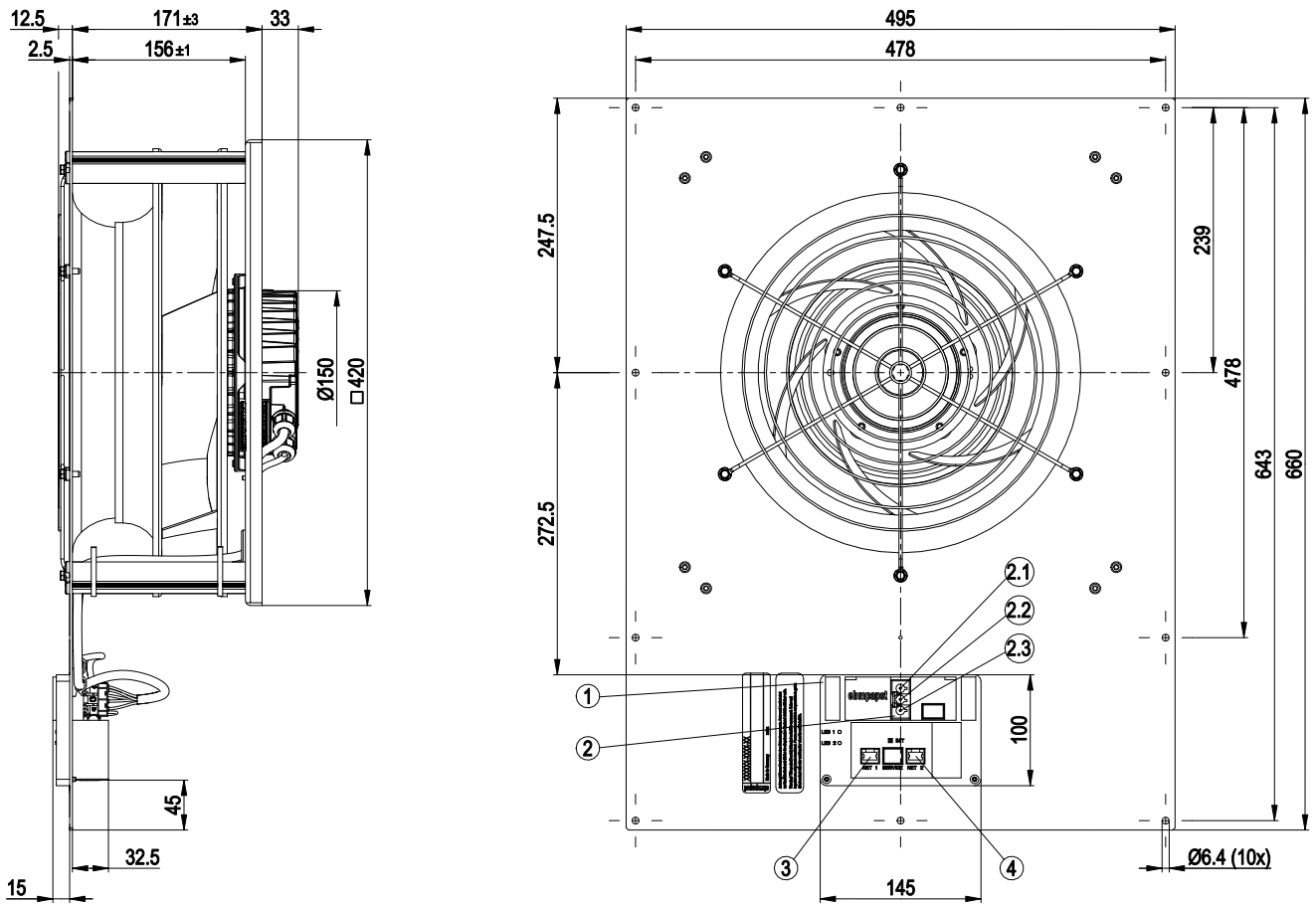

1	Terminal box
2	Connector housing 3-pole GST18/3 Wieland 92.032.9058.1
2.1	N
2.2	PE
2.3	L
3	Connector housing 8-pole Tyco 100616-2
4	Connector housing 8-pole Tyco 100616-2



EC centrifugal module

backward curved, single inlet
with support plate

Connection screen

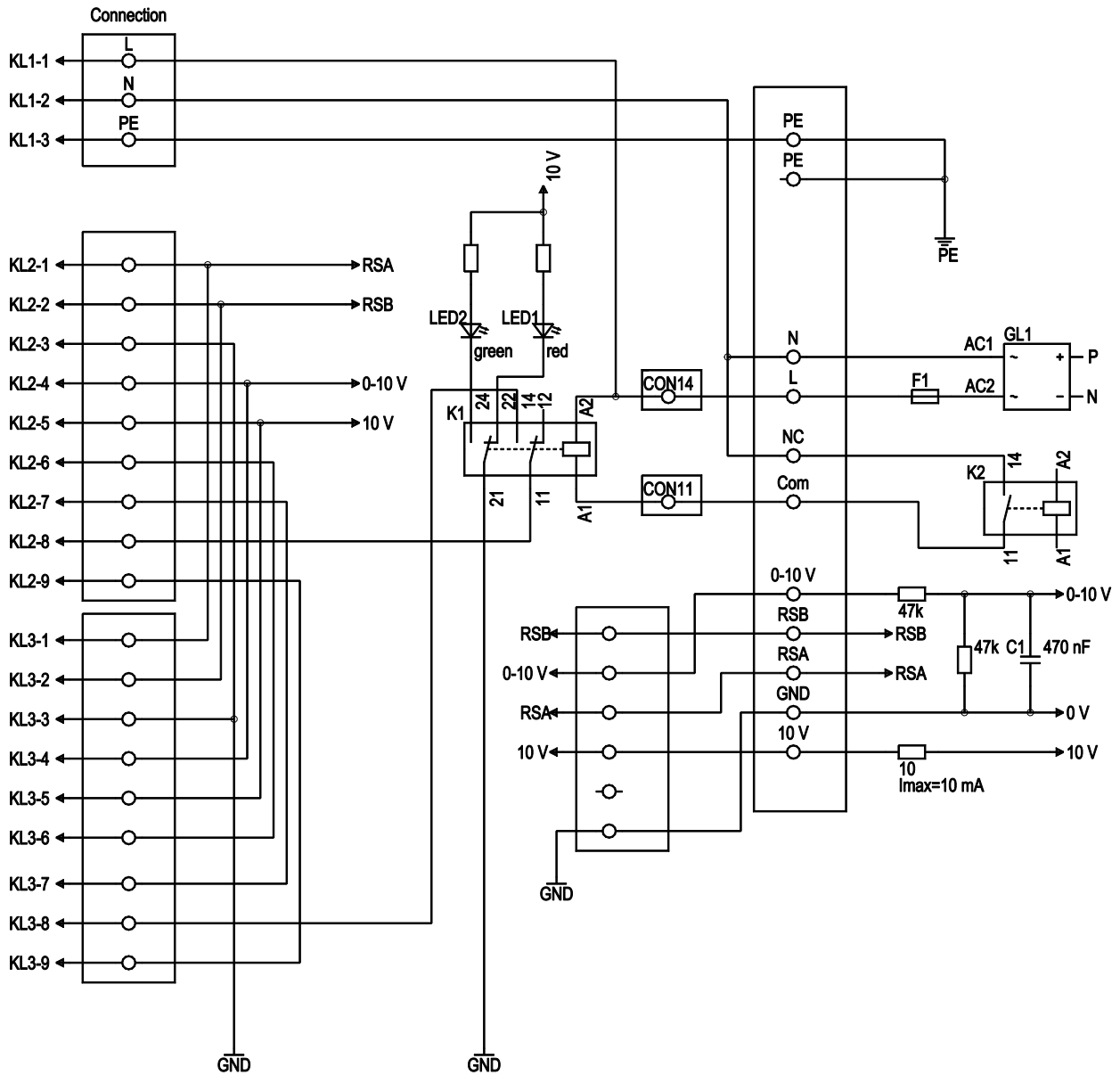

No.	Conn.	Designation	Colour	Function / assignment
1	1	L	black	Mains connection, power supply 1~ 200-277 VAC, 50/60 Hz
1	2	N	blue	Power supply, 1-phase, 200-277 VAC, 50/60 Hz
1	3	PE	green/yellow	Earth connection
2	1	RSA	-	Bus connection RS-485, RSA, MODBUS RTU; SELV
2	2	RSB	-	Bus connection RS-485, RSB, MODBUS RTU; SELV
2	3	GND	-	Reference earth for control interface; SELV
2	4	0-10 V	-	Control input
2	5	+10 V	-	Fixed voltage output 10 VDC
2	6	RES	-	Reserve
2	7	COM*	-	Alarm COM*
2	8	NC	-	NC KL2 UMAX 24 V
2	9	Schirm	-	Shield



EC centrifugal module

backward curved, single inlet

with support plate

No.	Conn.	Designation	Colour	Function / assignment
3	1	RSA	-	Bus connection RS-485, RSA, MODBUS RTU; SELV
3	2	RSB	-	Bus connection RS-485, RSB, MODBUS RTU; SELV
3	3	GND	-	Reference earth for interface; SELV
3	4	0-10 V	-	Control input
3	5	+10 V	-	Fixed voltage output 10 VDC
3	6	RES	-	Reserve
3	7	COM*	-	Alarm COM*
3	8	NC*	-	NC* KL3 UMAX 24 V
3	9	Schirm	-	Shield



Charts: Air flow 50 Hz

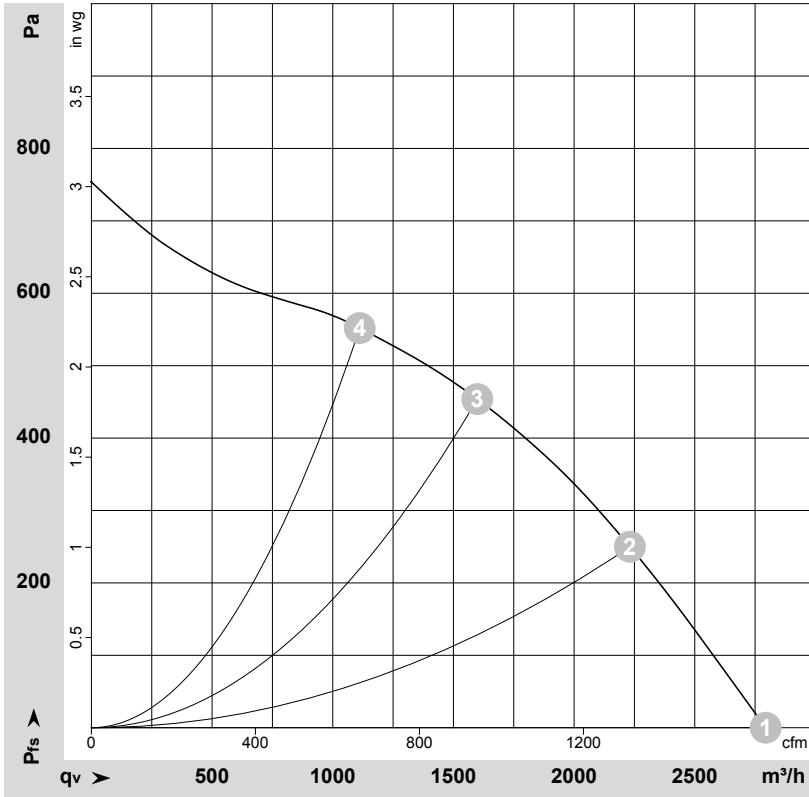

$\rho = 1.15 \text{ kg/m}^3 \pm 2 \%$

Measurement: LU-166149-1

Air performance measured as per ISO 5801 Installation category A. For detailed information on the measuring set-up, please contact ebmpapst. Suction-side noise levels: LwA measured as per ISO 13347 / LpA measured with 1m distance to fan axis. The values given are valid under the measuring conditions mentioned above and may vary according to the actual installation situation. With any deviation from the standard set-up, the specific values have to be checked and reviewed with the unit installed.

Measured values

	U	f	n	P _{ed}	I	q _v	P _{fs}	q _v	P _{fs}
	V	Hz	min ⁻¹	W	A	m ³ /h	Pa	cfm	inH2O
1	230	50	1755	288	1.28	2795	0	1645	0.00
2	230	50	1755	356	1.57	2230	250	1315	1.00
3	230	50	1750	380	1.67	1600	450	940	1.81
4	230	50	1755	358	1.58	1110	550	655	2.21

U = Supply voltage · f = Frequency · n = Speed (rpm) · P_{ed} = Power input · I = Current draw · q_v = Air flow · P_{fs} = Pressure increase

