

K3G355-PI93-05 ebmpapst Datasheet

sales@fansco.com

www.fansco.com

Nominal data

Type	K3G355-PI93-05	
Motor	M3G112-IA	
Phase		3~
Nominal voltage	VAC	400
Nominal voltage range	VAC	380 .. 480
Frequency	Hz	50/60
Type of data definition		ml
Speed (rpm)	min ⁻¹	3230
Power input	W	2680
Current draw	A	4.1
Min. ambient temperature	°C	-25
Max. ambient temperature	°C	40

ml = Max. load · me = Max. efficiency · fa = Running at free air · cs = Customer specs · cu = Customer unit
Subject to alterations

Data in accordance with ecodesign regulation EU 327/2011

		Actual	Request 2015
01 Overall efficiency η_{es}	%	67.9	55.8
02 Measurement category		A	
03 Efficiency category		Static	
04 Efficiency grade N		74.1	62
05 Variable speed drive		Yes	

Data definition with optimum efficiency.

The ErP data is determined using a motor-impeller combination in a standardised measurement configuration.

09 Power input P_{ed}	kW	2.59
09 Air flow q_v	m ³ /h	5525
09 Pressure increase p_{fs}	Pa	1075
10 Speed (rpm) n	min ⁻¹	3245
11 Specific ratio*		1.01

* Specific ratio = $1 + p_{fs} / 100\,000\text{ Pa}$

LU-174061



Technical features

Mass	27 kg
Size	355 mm
Motor size	112
Surface of rotor	Coated in black
Material of electronics housing	Die-cast aluminium
Material of impeller	Aluminium sheet
Material of mounting plate	Sheet steel, galvanised
Material of support bracket	Steel, coated in black
Material of inlet nozzle	Sheet steel, galvanised
Number of blades	5
Direction of rotation	Clockwise, seen on rotor
Type of protection	IP54
Insulation class	"B"
Humidity (F) / environmental protection class (H)	H1
Max. permissible ambient motor temp. (transp./ storage)	+80 °C
Min. permissible ambient motor temp. (transp./storage)	-40 °C
Mounting position	Refer to product drawing
Condensation drainage holes	Rotor-side
Operation mode	S1
Motor bearing	Ball bearing
Technical features	<ul style="list-style-type: none"> - Output 10 VDC, max. 10 mA - Output 20 VDC, max. 50 mA - Output for slave 0-10 V - Operation and alarm display - Input for sensor 0-10 V or 4-20 mA - External 24 V input (programming) - External release input - Alarm relay - Integrated PID controller - Output limit - Motor current limit - PFC, passive - RS485 MODBUS RTU - Soft start - Control input 0-10 VDC / PWM - Control interface with SELV potential safely disconnected from the mains - Over-temperature protected electronics / motor - Line undervoltage / phase failure detection
Touch current acc. IEC 60990 (measuring network Fig. 4, TN system)	<= 3.5 mA
Electrical connection	Terminal box
Motor protection	Thermal overload protector (TOP) wired internally
Protection class	I (if protective earth is connected by customer)
Product conforming to standard	EN 61800-5-1; CE
Approval	CSA C22.2 no. 77 + CAN/CSA-E60730-1; EAC; UL 1004-7 + 60730-1

EC centrifugal module - RadiPac

backward curved, single inlet
with support bracket

Product drawing

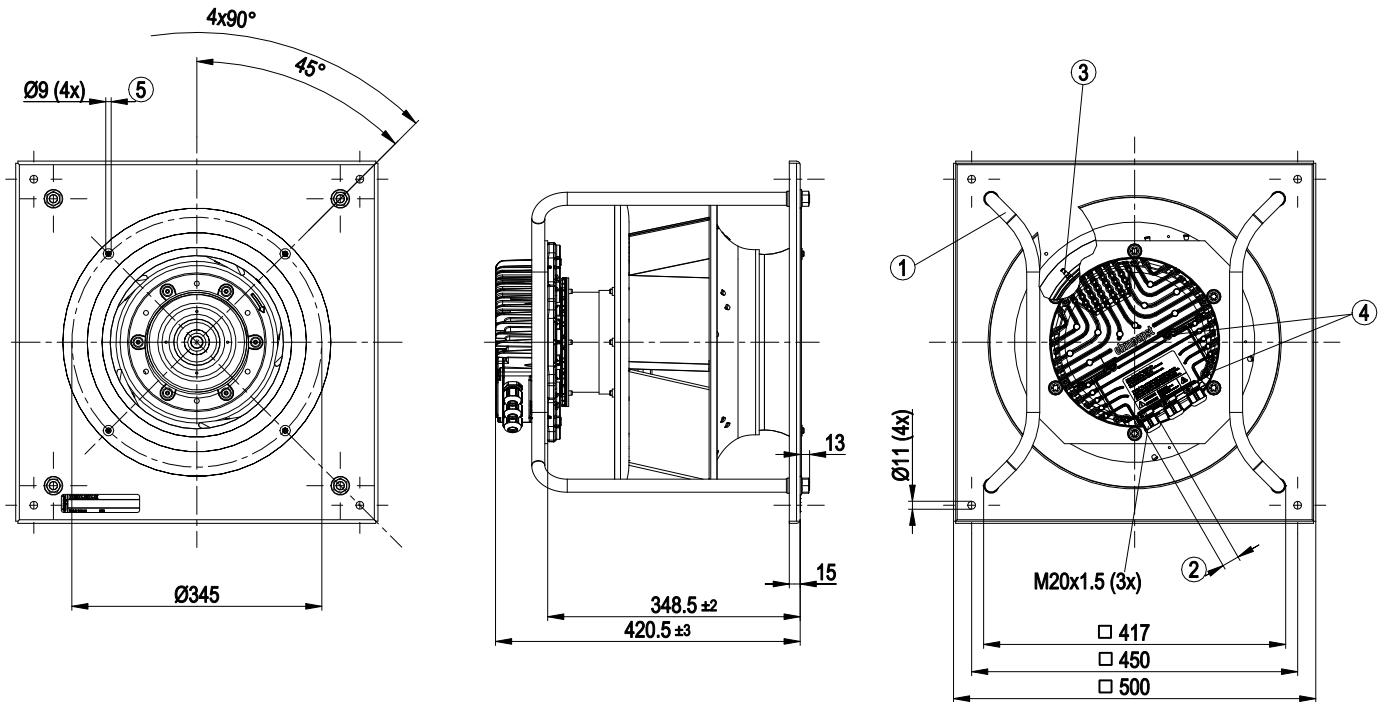

1	Installation position: Shaft horizontal (install the support struts only vertically as shown in the illustration!) or rotor on bottom; rotor on top on request
2	Cable diameter min. 4 mm, max. 10 mm, tightening torque 4 ± 0.6 Nm
3	Inlet nozzle with pressure tap (k-factor: 148)
4	Tightening torque 3.5 ± 0.5 Nm
5	Mounting holes for FlowGrid



EC centrifugal module - RadiPac

backward curved, single inlet

with support bracket

Connection screen

	8		
	Din 2		
	9		
	Din 3		
	10		
	GND		
	11		
	Ain 2 U		
	12		
	+ 20 V		
	13		
	Ain 2 I		
	14		
	Aout		

KL 3

1	NO
2	COM
3	NC

KL 2

PE

PE

1	L1
2	L2
3	L3

KL 1

No.	Conn.	Designation	Function / assignment
KL 1	1	L1	Mains supply connection, supply voltage 3~380-480 VAC; 50/60 Hz
KL 1	2	L2	Mains supply connection, supply voltage 3~380-480 VAC; 50/60 Hz
KL 1	3	L3	Mains supply connection, supply voltage 3~380-480 VAC; 50/60 Hz
PE		PE	Earth connection, PE connection
KL 2	1	NO	Status relay, floating status contact; normally open; close with error
KL2	2	COM	Status relay; floating status contact; changeover contact; common connection; contact rating 250 VAC / max. 2 A (AC1) / min. 10 mA
KL2	3	NC	Status relay, floating status contact; break with error
KL 3	1	RSA	Bus connection RS-485, RSA, MODBUS RTU; SELV
KL 3	2	RSB	Bus connection RS-485, RSB, MODBUS RTU; SELV
KL 3	3 / 10	GND	Signal ground for control interface; SELV
KL 3	4	Ain1 U	Analogue input 1, set value: 0-10 V, Ri = 100 kΩ, parametrisable curve, only usable as alternative to input Ain1; SELV
KL 3	5	+ 10 V	Fixed voltage output 10 VDC, +10 V ±3%, max. 10 mA, short-circuit-proof, power supply for external devices (e.g. potentiometer), SELV
KL 3	6	Ain1 I	Analogue input 1, set value: 4-20 mA; Ri = 100 Ω, parametrisable curve, only usable as alternative to input Ain1 U; SELV
KL 3	7	Din1	Digital input 1: enabling of electronics, enabling: open pin or applied voltage 5-50 VDC disabling: bridge to GND or applied voltage <1 VDC reset function: triggers software reset after a level change to <1 VDC; SELV
KL 3	8	Din2	Digital input 2: parameter set switch 1/2, according to EEPROM setting, the valid/used parameter set can be selected via bus or via digital input DIN2. Parameter set 1: open pin or applied voltage 5-50 VDC Parameter set 2: bridge to GND or applied voltage <1 VDC; SELV
KL 3	9	Din3	Digital input 3: controller function of integrated controller, according to EEPROM setting, the controller function of the integrated controller is normally/inversely selectable per bus or per digital input normal: open pin or applied voltage 5-50 VDC inverse: bridge to GND or applied voltage <1 VDC; SELV
KL 3	11	Ain2 U	Analogue input 2, actual value: 0-10 V, Ri = 100 kΩ, parametrisable curve, only usable as alternative to input Ain2; SELV
KL 3	12	+ 20 V	Fixed voltage output 20 VDC, +20 V ±5/-10%, max. 50 mA, short-circuit-proof, power supply for external devices (e.g. sensors); SELV



EC centrifugal module - RadiPac

backward curved, single inlet

with support bracket

No.	Conn.	Designation	Function / assignment
KL 3	13	Ain2 I	Analogue input 2, actual value: 4-20 mA, $R_i = 100 \Omega$, parametrisable curve, only usable as alternative to input Ain2 U; SELV
KL 3	14	Aout	Analogue output 0-10 VDC, max. 5 mA, output of the current motor level control coefficient / motor speed parametrisable curve; SELV



EC centrifugal module - RadiPac

backward curved, single inlet
with support bracket

Charts: Air flow 50 Hz

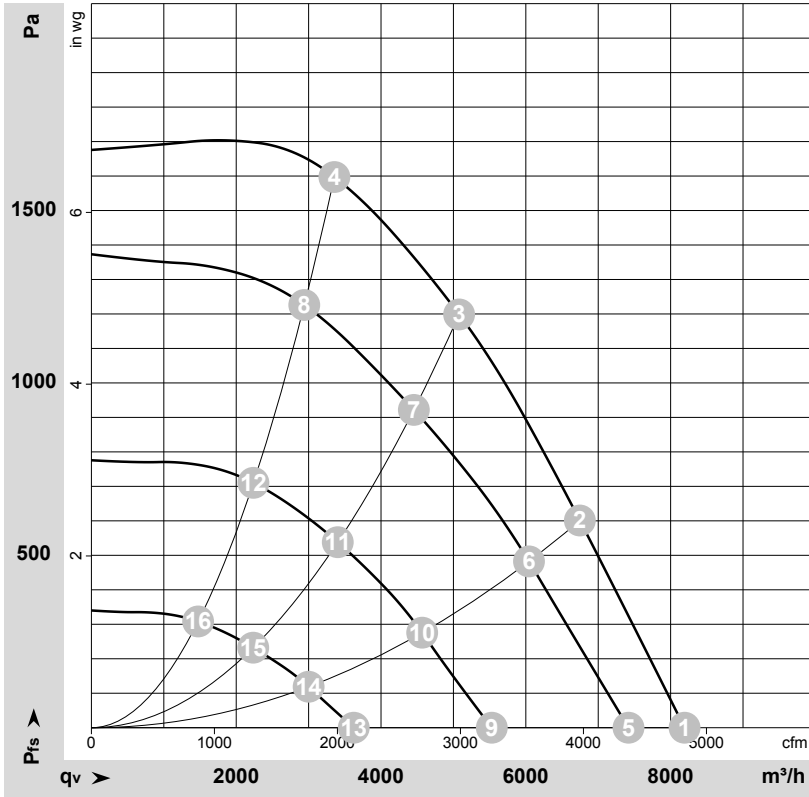

$\rho = 1.15 \text{ kg/m}^3 \pm 2 \%$

Measurement: LU-174061-1

Air performance measured as per ISO 5801 Installation category A. For detailed information on the measuring set-up, please contact ebmpapst. Suction-side noise levels: LwA measured as per ISO 13347 / LpA measured with 1m distance to fan axis. The values given are valid under the measuring conditions mentioned above and may vary according to the actual installation situation. With any deviation from the standard set-up, the specific values have to be checked and reviewed with the unit installed.

Measured values

	U	f	n	P _{ed}	I	LpA _{in}	LwA _{in}	LwA _{out}	q _v	P _{fs}	q _v	P _{fs}
	V	Hz	min ⁻¹	W	A	dB(A)	dB(A)	dB(A)	m ³ /h	Pa	cfm	in. wg
1	400	50	3230	1483	2.30	86	93	95	8190	0	4820	0.00
2	400	50	3230	2164	3.32	79	87	91	6745	600	3970	2.41
3	400	50	3230	2680	4.10	75	83	88	5080	1200	2990	4.82
4	400	50	3230	2560	3.94	79	87	91	3355	1600	1975	6.42
5	400	50	2955	1123	1.78	83	90	93	7420	0	4365	0.00
6	400	50	2885	1550	2.40	76	84	88	6045	483	3555	1.94
7	400	50	2840	1800	2.76	72	80	85	4455	922	2620	3.70
8	400	50	2845	1750	2.69	76	83	88	2940	1227	1730	4.93
9	400	50	2215	525	0.96	76	84	87	5530	0	3255	0.00
10	400	50	2185	718	1.22	70	78	82	4570	276	2690	1.11
11	400	50	2165	831	1.37	67	74	80	3405	538	2005	2.16
12	400	50	2165	815	1.35	70	77	81	2240	711	1315	2.85
13	400	50	1460	194	0.43	65	74	77	3625	0	2130	0.00
14	400	50	1440	248	0.51	60	68	73	3000	119	1765	0.48
15	400	50	1425	280	0.57	58	65	71	2235	232	1315	0.93
16	400	50	1425	276	0.56	59	66	72	1475	309	870	1.24

U = Supply voltage · f = Frequency · n = Speed (rpm) · P_{ed} = Power input · I = Current draw · LpA_{in} = Sound pressure level inlet side · LwA_{in} = Sound power level inlet side · LwA_{out} = Sound power level outlet side
q_v = Air flow · P_{fs} = Pressure increase

