

Nominal data

Type	K3G355-AM14-61	
Motor	M3G084-FA	
Phase		1~
Nominal voltage	VAC	230
Nominal voltage range	VAC	200 .. 277
Frequency	Hz	50/60
Type of data definition		fa
State		prelim.
Speed	min ⁻¹	1900
Power input	W	350
Current draw	A	1.5
Min. ambient temperature	°C	-25
Max. ambient temperature	°C	40

ml = max. load · me = max. efficiency · fa = running at free air · cs = customer specs · cu = customer unit
Subject to alterations

Data according to ErP directive

		Actual	Request 2013	Request 2015
Installation category	A			
Efficiency category	Static			
Variable speed drive	Yes			
Specific ratio*	1.00			
Overall efficiency η_{es}		60	43.5	47.5
Efficiency grade N		74.5	58	62
Power input P_{ed}	kW	0.42		
Air flow q_v	m ³ /h	2050		
Pressure increase p_{fs}	Pa	400		
Speed n	min ⁻¹	1770		

Data established at point of optimum efficiency

* Specific ratio = $1 + p_b / 100\,000\text{ Pa}$

Technical features

Mass	8.76 kg
Size	355 mm
Surface of rotor	Coated in black
Material of electronics housing	Die-cast aluminium
Material of impeller	Aluminium sheet
Material of mounting plate	Aluminium sheet
Material of distancing profiles	Aluminium
Material of inlet nozzle	Aluminium sheet
Number of blades	6
Direction of rotation	Clockwise, seen on rotor
Type of protection	IP 20
Insulation class	"B"
Humidity class	F0
Max. permissible ambient motor temp. (transp./ storage)	+80 °C
Min. permissible ambient motor temp. (transp./storage)	-40 °C
Mounting position	Shaft horizontal or rotor on top; rotor on bottom on request
Condensate discharge holes	None
Operation mode	S1
Motor bearing	Ball bearing
Technical features	<ul style="list-style-type: none"> - Over-temperature protected electronics / motor - PFC, active - Integrated PID controller - RS485 ebmBUS - Motor current limit - Soft start - Line undervoltage / phase failure detection - Operation and alarm display: reversible voltage output 0 V / +15 V
EMC interference immunity	Acc. to EN 61000-6-2 (industrial environment)
EMC harmonics	Acc. to EN 61000-3-2/3
EMC interference emission	Acc. to EN 61000-6-4 (industrial environment)
Touch current acc. IEC 60990 (measuring network Fig. 4, TN system)	<= 3.5 mA
Electrical leads	With plug
Motor protection	Thermal overload protector (TOP) wired internally
Protection class	I (if protective earth is connected by customer)
Product conforming to standard	EN 61800-5-1; CE
Approval	CSA C22.2 Nr.77; UL 2111

EC centrifugal module

backward curved, single inlet
with support plate

Product drawing

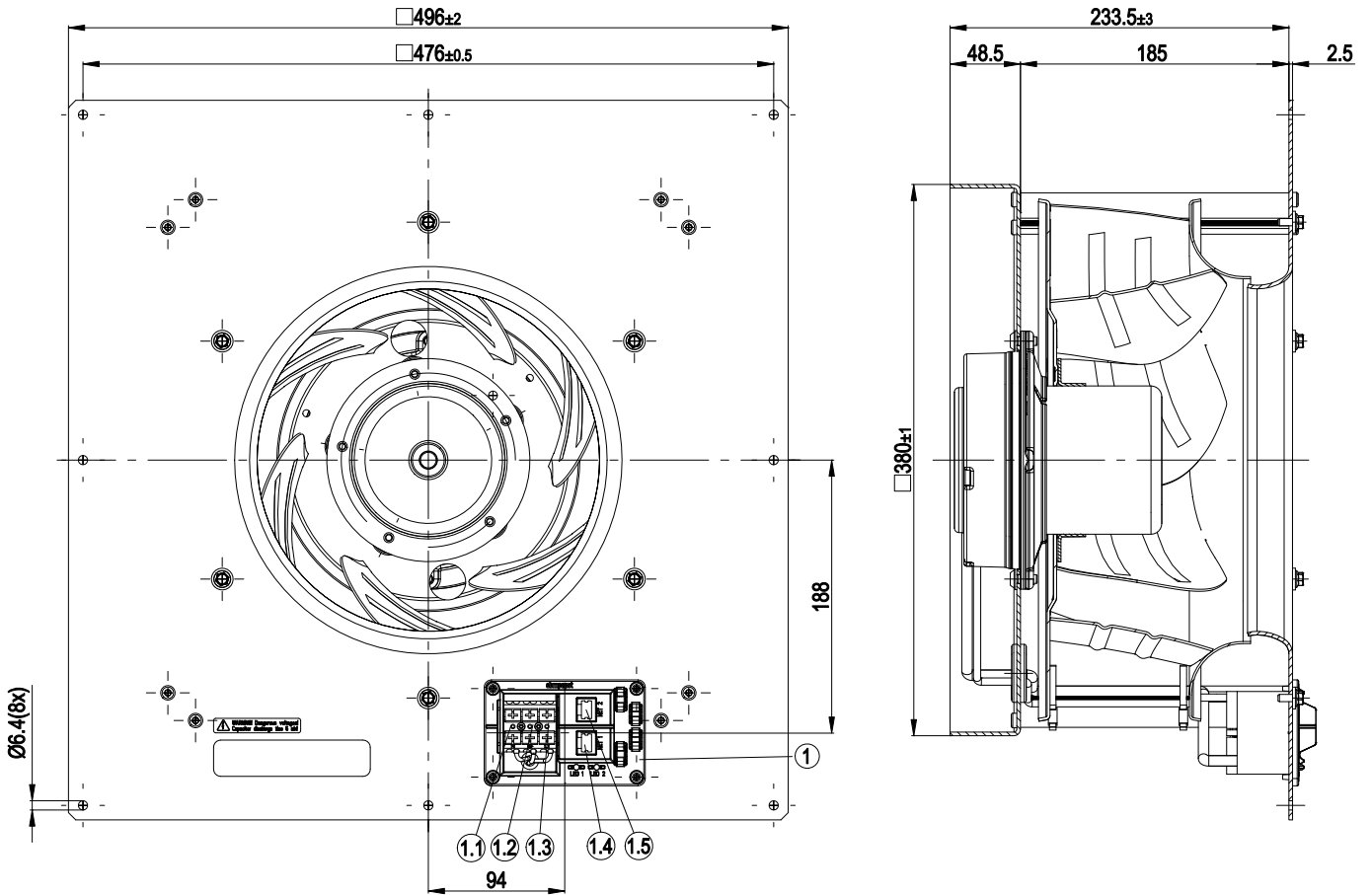

No.	Pin	Signal	Function / assignment
1			RS485 terminal box
1	1.1	N	Connection line AWG18, 1 x strand (black 2) with core-end sleeve
1	1.2	PE	Connection line AWG18, 1 x strand (green/yellow) with core-end sleeve
1	1.3	L	Connection line AWG18, 1 x strand (black 1) with core-end sleeve
1	1.4	RJ45 Buchse	RSB PIN 5 / RSA PIN 6
1	1.5	RJ45 Buchse	RSB PIN 5 / RSA PIN 6



EC centrifugal module

backward curved, single inlet
with support plate

Connection screen

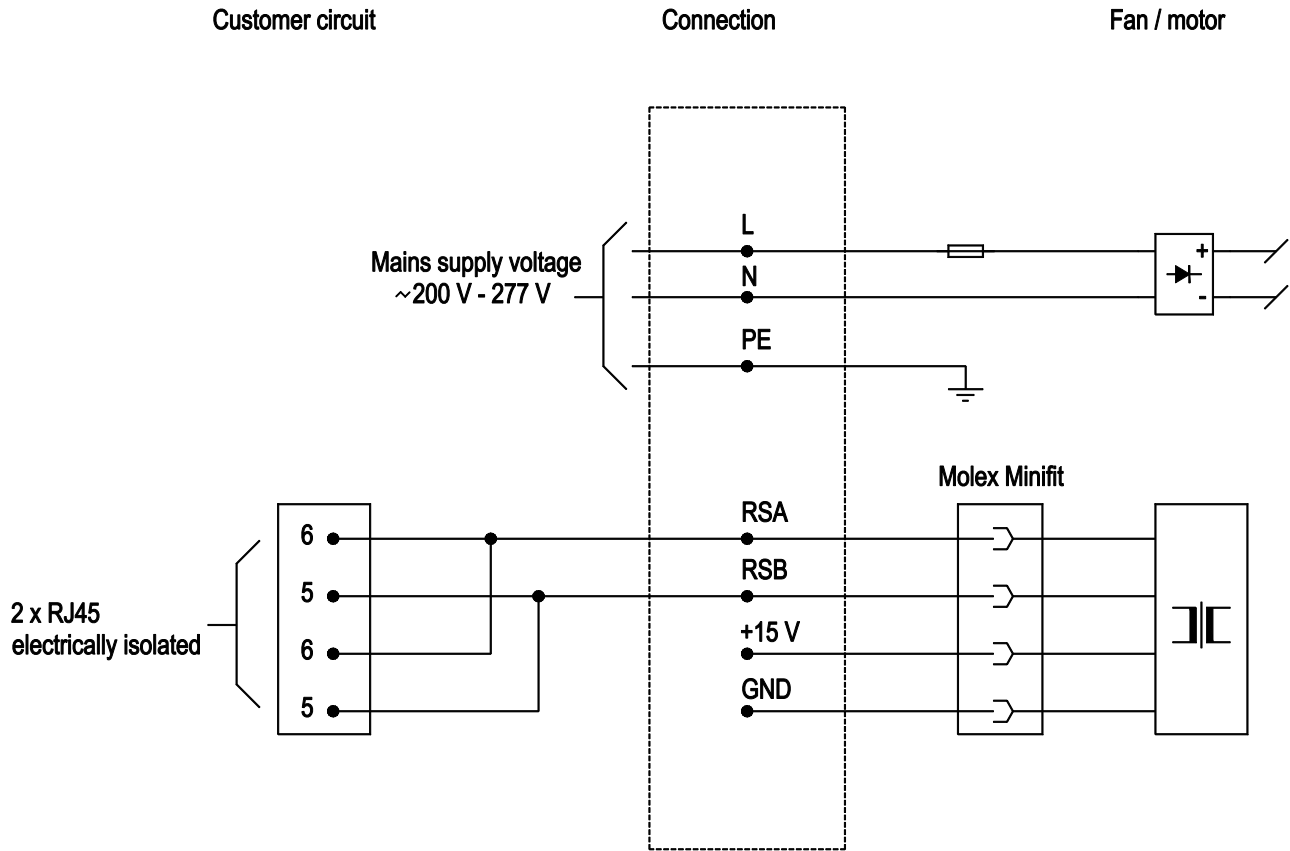

Charts: Air flow 50 Hz

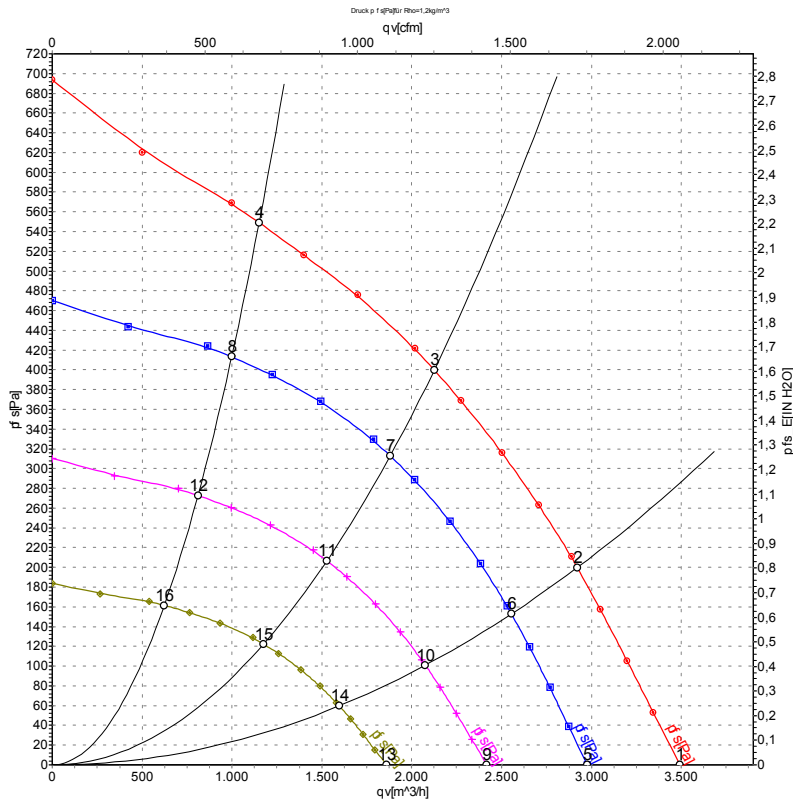

Measurement: LU-63219

Air performance measured as per ISO 5801 Installation category A. For detailed information on the measuring set-up, please contact ebm-papst. Suction-side noise levels: LwA measured as per ISO 13347 / LpA measured with 1m distance to fan axis. The values given are valid under the measuring conditions mentioned above and may vary according to the actual installation situation. With any deviation from the standard set-up, the specific values have to be checked and reviewed with the unit installed.

Measured values

	U	f	n	P _{ed}	I	qv	P _{fs}
	V	Hz	min ⁻¹	W	A	m ³ /h	Pa
1	230	50	1900	350	1.50	3500	0
2	230	50	1830	416	1.83	2920	200
3	230	50	1810	446	1.97	2125	400
4	230	50	1845	402	1.77	1150	550
5	230	50	1600	216	0.96	2975	0
6	230	50	1600	278	1.23	2555	153
7	230	50	1600	309	1.36	1880	313
8	230	50	1600	262	1.16	1000	413
9	230	50	1300	116	0.51	2420	0
10	230	50	1300	149	0.66	2075	101
11	230	50	1300	166	0.73	1530	207
12	230	50	1300	141	0.62	810	273
13	230	50	1000	53	0.23	1860	0
14	230	50	1000	68	0.30	1595	60
15	230	50	1000	75	0.33	1175	122
16	230	50	1000	64	0.28	625	162

U = Supply voltage · f = Frequency · n = Speed · P_{ed} = Power input · I = Current draw · qv = Air flow · P_{fs} = Pressure increase

