

backward curved, single inlet

with support bracket

K3G310-PS01-J9 ebmpapst Datasheet

sales@fansco.com

www.fansco.com

Limited partnership · Headquarters Muldingen  
County court Stuttgart · HRA 590344General partner Elektrobau Muldingen GmbH · Headquarters Muldingen  
County court Stuttgart · HRB 590142

## Nominal data

Type	K3G310-PS01-J9	
Motor	M3G084-FA	
Phase		3~
Nominal voltage	VAC	400
Nominal voltage range	VAC	380 .. 480
Frequency	Hz	50/60
Type of data definition		ml
State		prelim.
Speed (rpm)	min <sup>-1</sup>	3010
Power input	W	1230
Current draw	A	1.9
Min. ambient temperature	°C	-25
Max. ambient temperature	°C	50

ml = Max. load · me = Max. efficiency · fa = Running at free air · cs = Customer specs · cu = Customer unit  
Subject to alterations

## Data according to ErP directive

		Actual	Request 2015		
01 Overall efficiency $\eta_{es}$	%	67.5	52.4	09 Power input $P_{ed}$	kW
02 Measurement category		A		09 Air flow $q_v$	m <sup>3</sup> /h
03 Efficiency category		Static		09 Pressure increase $p_{fs}$	Pa
04 Efficiency grade N		77.1	62	10 Speed (rpm) $n$	min <sup>-1</sup>
05 Variable speed drive		Yes		11 Specific ratio <sup>*</sup>	
					1.01

Data definition with optimum efficiency.  
The ErP data is determined using a motor-impeller combination in a standardised measurement configuration.<sup>\*</sup> Specific ratio =  $1 + p_{fs} / 100\,000\text{ Pa}$ 

LU-177699



backward curved, single inlet  
with support bracket

### Technical features

Mass	0 kg
Size	310 mm
Surface of rotor	Coated in black
Material of terminal box	PP plastic
Material of electronics housing	Die-cast aluminium
Material of impeller	Aluminium sheet
Material of mounting plate	Sheet steel, galvanised
Material of support bracket	Steel, coated in black
Material of inlet nozzle	Sheet steel, galvanised
Number of blades	5
Direction of rotation	Clockwise, seen on rotor
Type of protection	IP 55
Insulation class	"F"
Humidity (F)/environmental protection class (H)	H1
Max. permissible ambient motor temp. (transp./ storage)	+80 °C
Min. permissible ambient motor temp. (transp./storage)	-40 °C
Mounting position	Shaft horizontal or rotor on bottom; rotor on top on request
Condensate discharge holes	Rotor-side
Operation mode	S1
Motor bearing	Ball bearing
Technical features	<ul style="list-style-type: none"> <li>- Output 10 VDC, max. 10 mA</li> <li>- Operation and alarm display</li> <li>- Alarm relay</li> <li>- Integrated PID controller</li> <li>- Output limit</li> <li>- Motor current limit</li> <li>- PFC, passive</li> <li>- RS485 MODBUS RTU</li> <li>- Soft start</li> <li>- Maximum EEPROM write cycles 100,000</li> <li>- Control input 0-10 VDC / PWM</li> <li>- Control interface with SELV potential safely disconnected from the mains</li> <li>- Temperature derating</li> <li>- Over-temperature protected electronics / motor</li> <li>- Line undervoltage / phase failure detection</li> </ul>
Touch current acc. IEC 60990 (measuring network Fig. 4, TN system)	<= 3.5 mA
Electrical leads	Via terminal box
Motor protection	Thermal overload protector (TOP) wired internally
Protection class	I (if protective earth is connected by customer)
Product conforming to standard	EN 61800-5-1; CE
Approval	C22.2 Nr.77 + CAN/CSA-E60730-1; UL 1004-7 + 60730



# EC centrifugal module - RadiPac

backward curved, single inlet  
with support bracket

## Product drawing

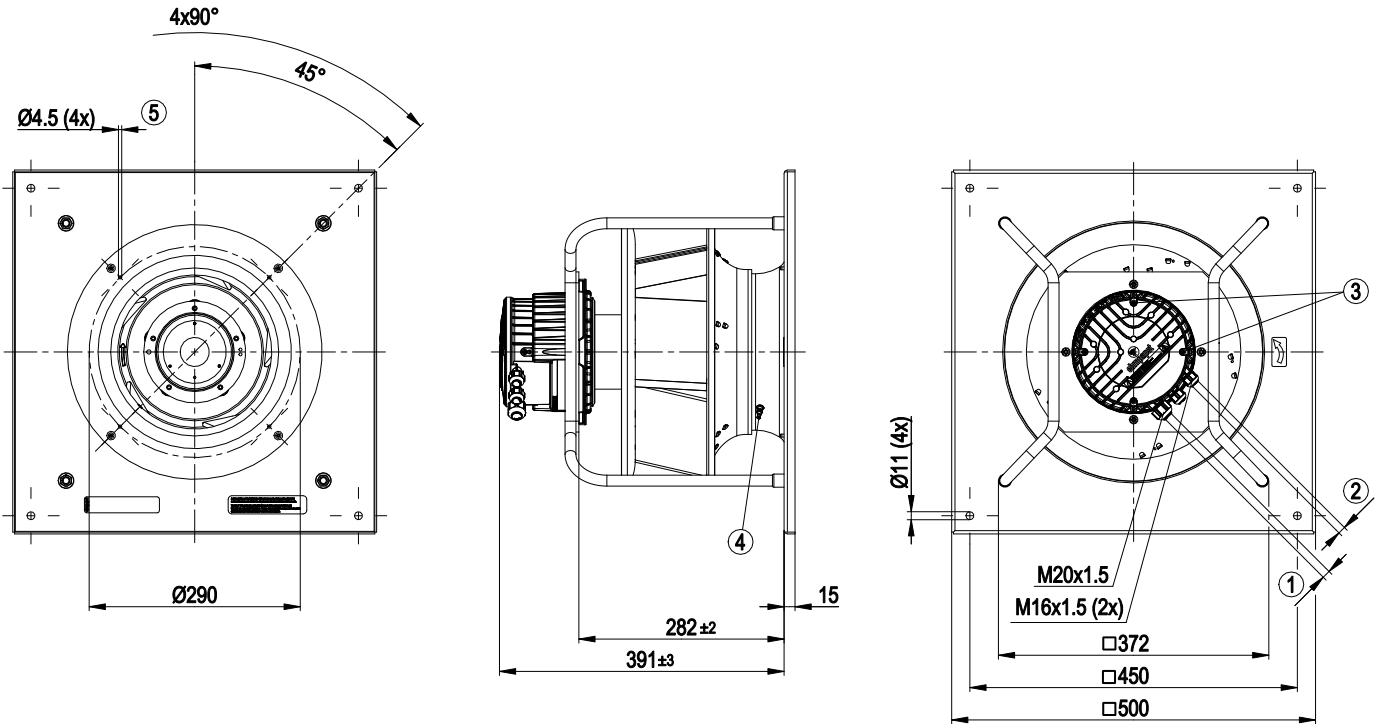

1	Cable diameter min. 8 mm, max. 12 mm, tightening torque 2.5±0.4 Nm
2	Cable diameter min. 6 mm, max. 10 mm, tightening torque 2.5±0.4 Nm Cable diameter min. 4 mm, max. 7 mm, tightening torque 2.5±0.4 Nm (use must be made of sealing ring provided)
3	Tightening torque 1.5±0.2 Nm
4	Inlet nozzle with pressure tap (k-factor: 116)
5	Mounting holes for FlowGrid



backward curved, single inlet  
with support bracket

### Connection screen

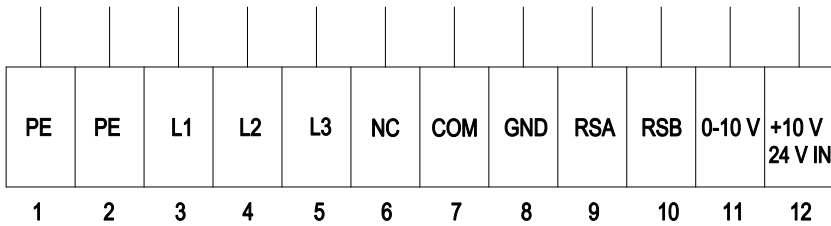

No.	Conn.	Designation	Function / assignment
1	PE	PE	Protective earth
2	PE	PE	Protective earth
3	L1	L1	Power supply
4	L2	L2	Power supply
5	L3	L3	Power supply
6	NC	NC	Status relay, floating status contact, break for failure, contact rating 250 VAC/30 VDC 5 A minimum contact load 1 mA/5 VDC; reinforced insulation with respect to mains and basic insulation with respect to control interface
7	COM	COM	Status relay, floating status contact, common connection, contact rating 250 VAC/30 VDC 5 A minimum contact load 1 mA/5 VDC; reinforced insulation with respect to mains and basic insulation with respect to control interface
8	GND	GND	Signal ground for control interface, SELV
9	RSA	RSA	RS-485 interface for MODBUS, RSA; SELV
10	RSB	RSB	RS-485 interface for MODBUS, RSB; SELV
11	0-10 V	0-10 V	Analogue input (set value) SELV, 0-10 V, Ri=100kΩ, parametrisable curve
12	+10 V	+10 V	Fixed voltage output 10 VDC, SELV, +10 V +/-3%, max. 10 mA, short-circuit-proof, power supply for external devices (e.g. potentiometers)



# EC centrifugal module - RadiPac

backward curved, single inlet  
with support bracket

## Charts: Air flow 50 Hz

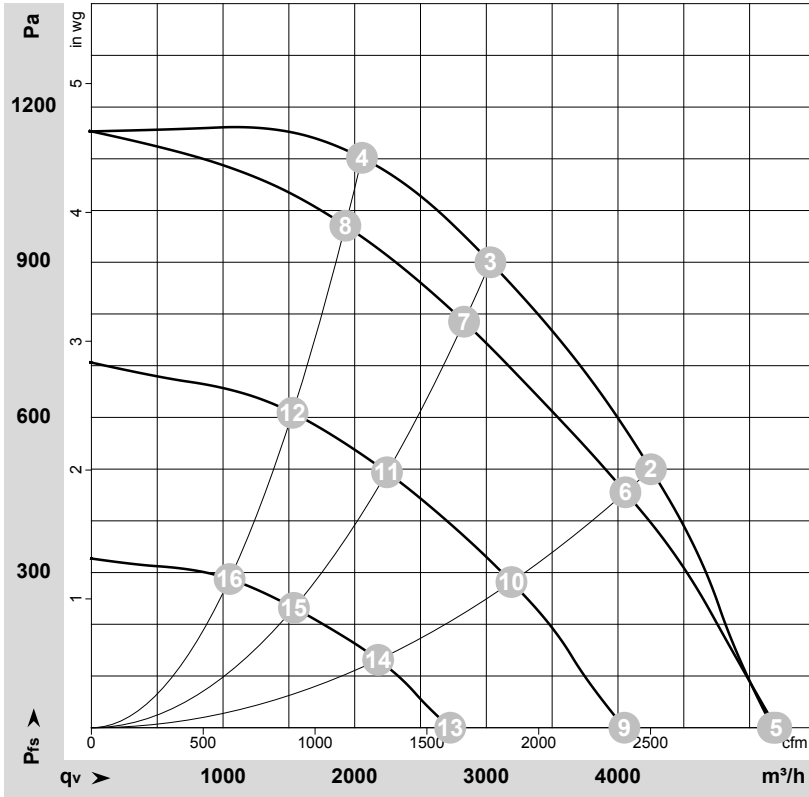

$\rho = 1.15 \text{ kg/m}^3 \pm 2 \%$

Measurement: LU-177699-1

Air performance measured as per ISO 5801 Installation category A. For detailed information on the measuring set-up, please contact ebmpapst. Suction-side noise levels: LwA measured as per ISO 13347 / LpA measured with 1m distance to fan axis. The values given are valid under the measuring conditions mentioned above and may vary according to the actual installation situation. With any deviation from the standard set-up, the specific values have to be checked and reviewed with the unit installed.

## Measured values

	U	f	n	P <sub>ed</sub>	I	LpA <sub>in</sub>	LwA <sub>in</sub>	LwA <sub>out</sub>	q <sub>v</sub>	P <sub>fs</sub>	q <sub>v</sub>	P <sub>fs</sub>
	V	Hz	min <sup>-1</sup>	W	A	dB(A)	dB(A)	dB(A)	m <sup>3</sup> /h	Pa	cfm	inH <sub>2</sub> O
1	400	50	3010	634	1.00	84	92	94	5175	0	3045	0.00
2	400	50	3010	1052	1.62	75	83	86	4250	500	2500	2.01
3	400	50	3010	1230	1.90	70	78	82	3030	900	1785	3.61
4	400	50	3010	1173	1.80	77	85	87	2055	1100	1210	4.42
5	400	50	3020	638	1.00	84	92	94	5200	0	3060	0.00
6	400	50	2875	917	1.42	74	82	85	4055	456	2385	1.83
7	400	50	2820	986	1.52	68	76	80	2830	788	1665	3.16
8	400	50	2830	971	1.49	76	83	85	1930	971	1135	3.90
9	400	50	2365	321	0.56	78	86	87	4050	0	2385	0.00
10	400	50	2265	455	0.74	68	76	79	3190	282	1880	1.13
11	400	50	2235	498	0.81	62	70	74	2245	496	1320	1.99
12	400	50	2240	488	0.79	70	76	78	1530	609	900	2.44
13	400	50	1605	121	0.29	68	77	77	2725	0	1605	0.00
14	400	50	1550	165	0.35	59	67	70	2180	132	1280	0.53
15	400	50	1535	180	0.37	53	61	67	1540	233	905	0.94
16	400	50	1540	177	0.37	58	66	69	1050	288	620	1.16

U = Supply voltage · f = Frequency · n = Speed (rpm) · P<sub>ed</sub> = Power input · I = Current draw · LpA<sub>in</sub> = Sound pressure level inlet side · LwA<sub>in</sub> = Sound power level inlet side · LwA<sub>out</sub> = Sound power level outlet side  
q<sub>v</sub> = Air flow · P<sub>fs</sub> = Pressure increase

