

EC centrifugal module - Plug fan

backward curved, single inlet

with support bracket

K3G310-AX54-25 ebmpapst Datasheet

sales@fansco.com

www.fansco.com

Limited partnership · Headquarters Muldingen
County court Stuttgart · HRA 590344

General partner Elektrobau Muldingen GmbH · Headquarters Muldingen
County court Stuttgart · HRB 590142



Nominal data

Type	K3G310-AX54-25	
Motor	M3G112-EA	
Phase		1~
Nominal voltage	VAC	230
Nominal voltage range	VAC	200 .. 277
Frequency	Hz	50/60
Type of data definition		ml
Speed	min ⁻¹	2850
Power input	W	1270
Current draw	A	5.6
Min. ambient temperature	°C	-25
Max. ambient temperature	°C	55

ml = Max. load · me = Max. efficiency · fa = Running at free air · cs = Customer specs · cu = Customer unit
Subject to alterations

Data according to ErP directive

Installation category	A
Efficiency category	Static
Variable speed drive	Yes
Specific ratio*	1.01

* Specific ratio = $1 + p_{fs} / 100\,000\text{ Pa}$

		Actual	Request 2013	Request 2015
Overall efficiency η_{es}		59.4	48.6	52.6
Efficiency grade N		68.8	58	62
Power input P_{ed}	kW	1.27		
Air flow q_v	m ³ /h	2795		
Pressure increase p_{fs}	Pa	903		
Speed n	min ⁻¹	2840		

Data definition with optimum efficiency.
The ErP data is determined using a motor-impeller combination in a standardised measurement configuration.



Technical features

Mass	20.5 kg
Size	310 mm
Surface of rotor	Coated in black
Material of electronics housing	Die-cast aluminium, coated in black
Material of impeller	Aluminium sheet, coated in black
Material of mounting plate	Sheet steel, hot-galvanised and coated in black
Material of support bracket	Steel, galvanised and coated in black
Material of inlet nozzle	Sheet steel, hot-galvanised and coated in black
Number of blades	7
Direction of rotation	Clockwise, seen on rotor
Type of protection	IP 54
Insulation class	"B"
Humidity class	F4-2
Max. permissible ambient motor temp. (transp./ storage)	+80 °C
Min. permissible ambient motor temp. (transp./storage)	-40 °C
Mounting position	Shaft horizontal or rotor on bottom; rotor on top on request
Condensate discharge holes	Rotor-side
Operation mode	S1
Motor bearing	Ball bearing
Technical features	<ul style="list-style-type: none"> - Output 10 VDC, max. 10 mA - Output 20 VDC, max. 50 mA - Output for slave 0-10 V - Tach output - Input for sensor 0-10 V or 4-20 mA - Alarm relay - Integrated PID controller - Motor current limit - PFC, active - RS485 MODBUS RTU - Soft start - Control input 0-10 VDC / PWM - Control interface with SELV potential safely disconnected from the mains - Over-temperature protected electronics / motor - Line undervoltage / phase failure detection
Touch current acc. IEC 60990 (measuring network Fig. 4, TN system)	<= 3.5 mA
Electrical leads	Via terminal box
Motor protection	Thermal overload protector (TOP) wired internally
Protection class	I (if protective earth is connected by customer)
Product conforming to standard	EN 61800-5-1; CE

EC centrifugal module - Plug fan

backward curved, single inlet
with support bracket

Product drawing

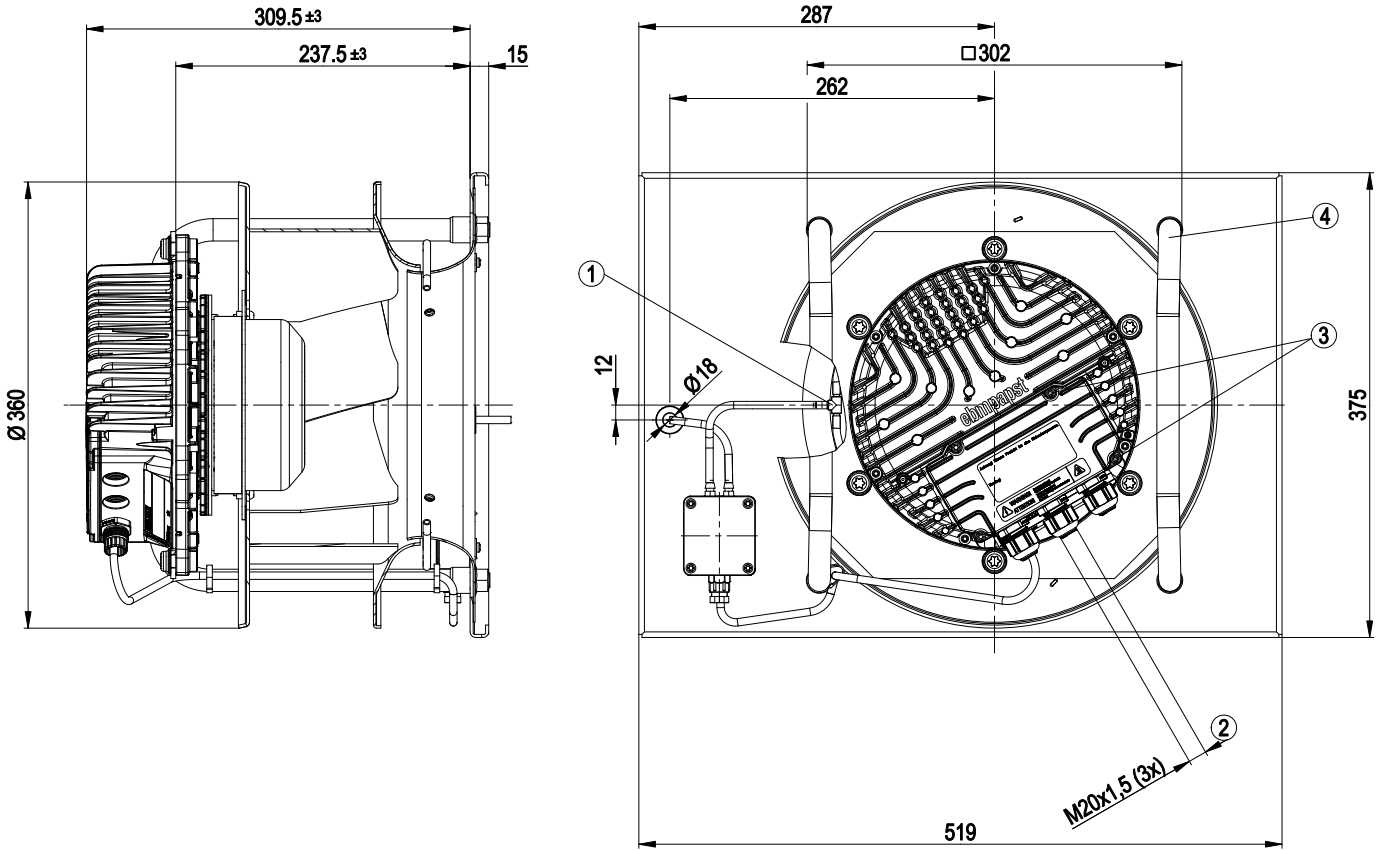

1	Inlet nozzle with pressure-measuring point in the pressure sensor (0-1500Pa).
2	Cable diameter: min. 4 mm, max. 10 mm, tightening torque: 4.0±0.6 Nm
3	Tightening torque 3.5±0.5 Nm
4	Mounting position: shaft horizontal (install the support struts only vertically as shown in the view!) or rotor on bottom; rotor on top on request



EC centrifugal module - Plug fan

backward curved, single inlet

with support bracket

Connection screen

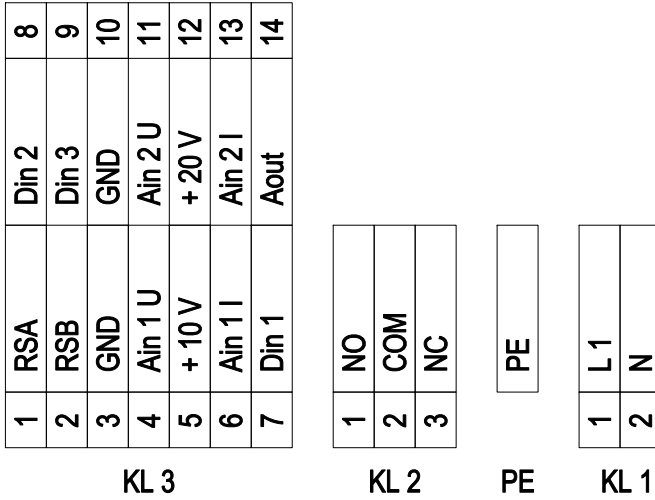

No.	Pin	Signal	Function / assignment
KL1	1	L1	Mains supply connection, supply voltage 1~200-277 V AC; 50/60 Hz
KL1	2	N	Mains supply connection, supply voltage 1~200-277 V AC; 50/60 Hz
PE		PE	Earth connection, PE connection
KL2	1	NO	Status relay, floating status contact; option 1: close with error; option 2: close with run monitor error message
KL2	2	COM	Status relay; floating status contact; changeover contact; common connection; contact rating 250 VAC / max. 2 A (AC1) / min. 10 mA
KL2	3	NC	Status relay, floating status contact; option 1: break with error; option 2: break with error for run monitor error message
KL3	1	RSA	Bus connection RS485; RSA; MODBUS RTU
KL3	2	RSB	Bus connection RS485; RSB; MODBUS RTU
KL3	3	GND	Signal ground for control interface
KL3	4	Ain1 U	Analog input 1 (set value); 0-10 V; Ri= 100kOhm; parametrisable curve; only usable as alternative to input Ain1 I
KL3	5	+10 V	Fixed voltage output 10 VDC; + 10 V +/-3%; max. 10 mA; short circuit proof; power supply for ext. devices (e.g. potentiometer)
KL3	6	Ain1 I	Analog input 1 (set value); 4-20 mA; Ri= 100 Ohm; parametrisable curve; only usable as alternative to input Ain1 U
KL3	7	Din1	Digital input 1: enabling of electronics; enabling: open pin or applied voltage 5 to 50 VDC; disabling: bridge to GND or applied voltage < 0.8 VDC; reset function: triggers software reset after a level change to <0.8 V
KL3	8	Din2	Digital input 2: parameter set switch 1/2; according to EEPROM setting, the valid/used parameter set is selectable per BUS or per digital input DIN2. Parameter set 1: open pin or applied voltage 5 to 50 VDC; parameter set 2: bridge to GND or applied voltage < 0.8 VDC
KL3	9	Din3	Digital input 3: control characteristic of the integrated controller; according to EEPROM setting, the control characteristic of the integrated controller is normally/inversely selectable per BUS or per digital input; normal: open pin or applied voltage 5 to 50 VDC; inverse: bridge to GND or applied voltage < 0.8 VDC
KL3	10	GND	Signal ground for control interface
KL3	11	Ain2 U	Analog input 2; actual sensor value 0-10 V; Ri= 100kOhm; parametrisable curve; only usable as alternative to input Ain2 I
KL3	12	+20 V	Fixed voltage output 20 VDC; + 20V +/-25/-10%; max. 50 mA; short circuit proof; power supply for ext. devices (e.g. sensors)
KL3	13	Ain2 I	Analog input 2; actual sensor value 4-20 mA; Ri= 100 Ohm; parametrisable curve; only alternative to input Ain2 U
KL3	14	Aout	Analogue output 0-10 V; max. 5 mA; output of the actual motor control factor (output voltage of electronics)/ of the actual motor speed. Parametrisable curve.



Charts: Air flow 50 Hz

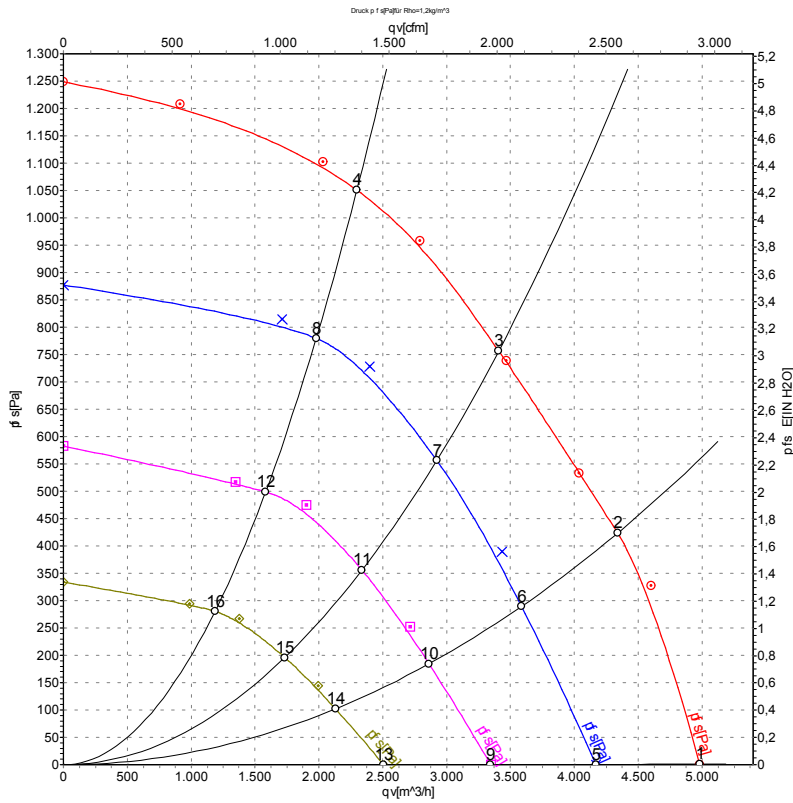

Measurement: LU-12620
 Measurement: LU-131413
 Measurement: LU-131415
 Measurement: LU-131416

Air performance measured as per ISO 5801 Installation category A. For detailed information on the measuring set-up, please contact ebm-papst. Suction-side noise levels: LwA measured as per ISO 13347 / LpA measured with 1m distance to fan axis. The values given are valid under the measuring conditions mentioned above and may vary according to the actual installation situation. With any deviation from the standard set-up, the specific values have to be checked and reviewed with the unit installed.

Measured values

	U	f	n	P _{ed}	I	LpA _{in}	LwA _{in}	LwA _{out}	qv	p _{fs}
	V	Hz	min ⁻¹	W	A	dB(A)	dB(A)	dB(A)	m ³ /h	Pa
1	230	50	2930	946	4.14	81	88	94	4980	0
2	230	50	2895	1147	5.01	76	83	90	4340	425
3	230	50	2850	1270	5.60	72	79	87	3410	760
4	230	50	2850	1237	5.41	75	83	89	2300	1050
5	230	50	2430	529	2.34	77	84	89	4165	0
6	230	50	2430	663	2.91	71	78	85	3585	309
7	230	50	2430	743	3.26	70	77	84	2925	556
8	230	50	2430	751	3.29	71	78	85	1980	781
9	230	50	1955	299	1.36	71	78	83	3345	0
10	230	50	1955	360	1.61	66	73	79	2860	193
11	230	50	1955	398	1.77	65	72	78	2335	356
12	230	50	1955	400	1.78	66	73	79	1585	499
13	230	50	1465	139	0.72	64	71	76	2505	0
14	230	50	1465	159	0.79	59	67	73	2130	106
15	230	50	1465	177	0.86	58	65	72	1735	196
16	230	50	1465	184	0.89	59	66	73	1185	280

U = Supply voltage · f = Frequency · n = Speed · P_{ed} = Power input · I = Current draw · LpA_{in} = Sound pressure level inlet side · LwA_{in} = Sound power level inlet side · LwA_{out} = Sound power level outlet side
 qv = Air flow · p_{fs} = Pressure increase

