

K3G280-AU11-C9 ebmpapst Datasheet

sales@fansco.com

www.fansco.com

## Nominal data

Type	K3G280-AU11-C9	
Motor	M3G084-GF	
Phase		3~
Nominal voltage	VAC	400
Nominal voltage range	VAC	380 .. 480
Frequency	Hz	50/60
Type of data definition		ml
Speed	min <sup>-1</sup>	3100
Power input	W	1000
Current draw	A	1.6
Min. ambient temperature	°C	-25
Max. ambient temperature	°C	60

ml = Max. load · me = Max. efficiency · fa = Running at free air · cs = Customer specs · cu = Customer unit  
Subject to alterations

## Data according to ErP directive

Installation category	A
Efficiency category	Static
Variable speed drive	Yes
Specific ratio*	1.01

\* Specific ratio =  $1 + p_{fs} / 100\,000\text{ Pa}$

		Actual	Request 2013	Request 2015
Overall efficiency $\eta_{es}$	%	61.4	47.5	51.5
Efficiency grade N		71.9	58	62
Power input $P_{ed}$	kW	0.99		
Air flow $q_v$	m <sup>3</sup> /h	2675		
Pressure increase $p_{fs}$	Pa	758		
Speed n	min <sup>-1</sup>	3115		

Data definition with optimum efficiency. LU-130335  
The ErP data is determined using a motor-impeller combination in a standardised measurement configuration.

### Technical features

Mass	13.4 kg
Size	280 mm
Surface of rotor	Coated in black
Material of electronics housing	Die-cast aluminium
Material of impeller	Aluminium sheet
Material of mounting plate	Sheet steel, galvanised
Material of support bracket	Steel, coated in black
Material of inlet nozzle	Sheet steel, galvanised
Number of blades	7
Direction of rotation	Clockwise, seen on rotor
Type of protection	IP 54
Insulation class	"B"
Humidity class	F3-1
Max. permissible ambient motor temp. (transp./ storage)	+80 °C
Min. permissible ambient motor temp. (transp./storage)	-40 °C
Mounting position	Shaft horizontal or rotor on bottom; rotor on top on request
Condensate discharge holes	Rotor-side
Operation mode	S1
Motor bearing	Ball bearing
Technical features	<ul style="list-style-type: none"> <li>- Output 10 VDC, max. 10 mA</li> <li>- Output 20 VDC, max. 50 mA</li> <li>- Output for slave 0-10 V</li> <li>- Input for sensor 0-10 V or 4-20 mA</li> <li>- External 24 V input (programming)</li> <li>- Alarm relay</li> <li>- Output limit</li> <li>- Motor current limit</li> <li>- RS485 MODBUS RTU</li> <li>- Soft start</li> <li>- Control input 0-10 VDC / PWM</li> <li>- Control interface with SELV potential safely disconnected from the mains</li> <li>- Over-temperature protected electronics / motor</li> <li>- Line undervoltage / phase failure detection</li> </ul>
Touch current acc. IEC 60990 (measuring network Fig. 4, TN system)	<= 3.5 mA
Electrical leads	Via terminal box
Motor protection	Thermal overload protector (TOP) wired internally
Protection class	I (if protective earth is connected by customer at the connection point of the housing)
Product conforming to standard	EN 61800-5-1; CE
Approval	C22.2 Nr.77 + CAN/CSA-E60730-1; EAC; UL 1004-7 + 60730

# EC centrifugal module - RadiPac

backward curved, single inlet  
with support bracket

## Product drawing

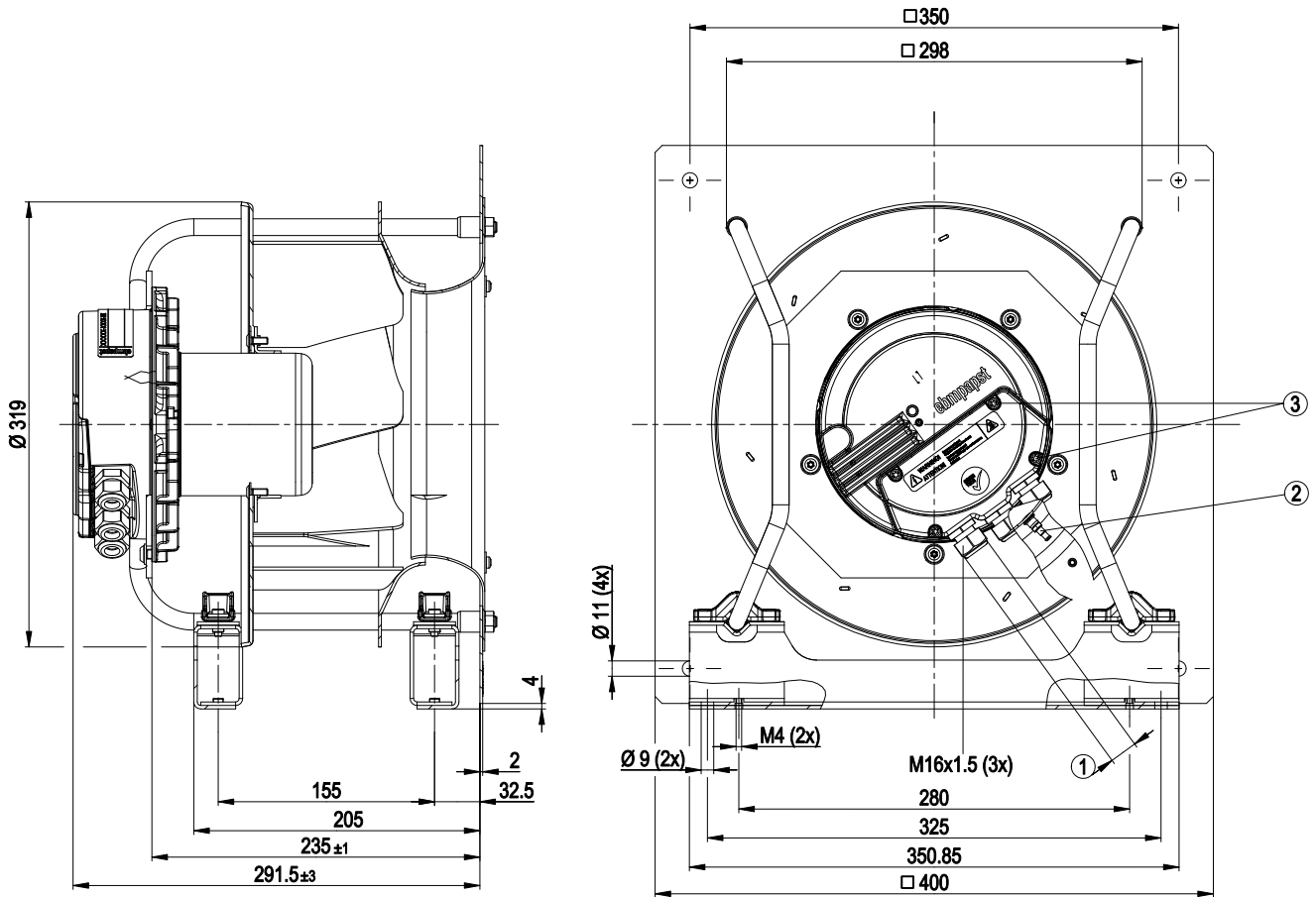

- |   |  |
|---|--|
| 1 | Cable diameter: min. 4 mm, max. 10 mm, tightening torque: 2.5±0.4 Nm |
| 2 | Pressure tap (k-factor 93)   |
| 3 | Tightening torque 3.5±0.5 Nm   |



# EC centrifugal module - RadiPac

backward curved, single inlet  
with support bracket

## Connection screen

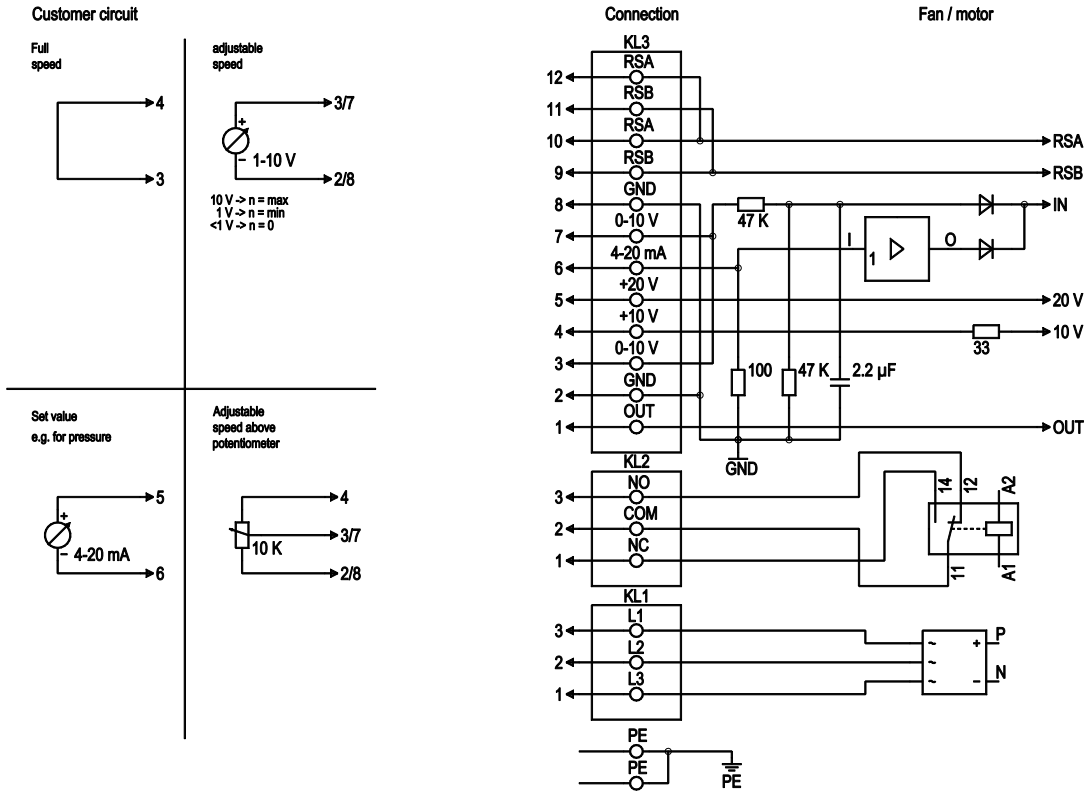

No.	Conn.	Designation	Function / assignment
PE		PE	Protective earth connection
KL1	1, 2, 3	L1, L2, L3	Supply voltage, voltage range (see type plate), 50/60 Hz
KL2	1	NC	Floating status contact, break with error
KL2	2	COM	Floating status contact, changeover contact, common connection (2 A, max. 250 VAC, min. 10 mA, AC1)
KL2	3	NO	Floating status contact, close with error
KL3	1	OUT	Analogue output, 0-10 VDC, max. 3 mA, SELV, Output of the actual motor duty cycle (PWM): 1 V corresponds to 10% PWM, 10 V correspond to 100% PWM.
KL3	2, 8	GND	Signal ground for control interface, SELV
KL3	3, 7	0-10 V	Set value / actual sensor value input 0-10 VDC, impedance 100 kΩ only as alternative to 4-20 mA input, SELV
KL3	4	+10 V	Voltage output 10 VDC (+/-3%), max. 10 mA, power supply for external devices (e.g. potentiometer), SELV
KL3	5	+20 V	Voltage output 20 VDC (+25%/-10%), max. 50 mA, supply voltage for external devices (e.g. sensors), SELV
KL3	6	4-20 mA	Set value / actual sensor value input 4-20 mA, impedance 100 Ω, only as alternative to 0-10 V input, SELV
KL3	9, 11	RSB	RS485 interface for MODBUS, RSB
KL3	10, 12	RSA	RS485 interface for MODBUS, RSA



## Charts: Air flow 50 Hz

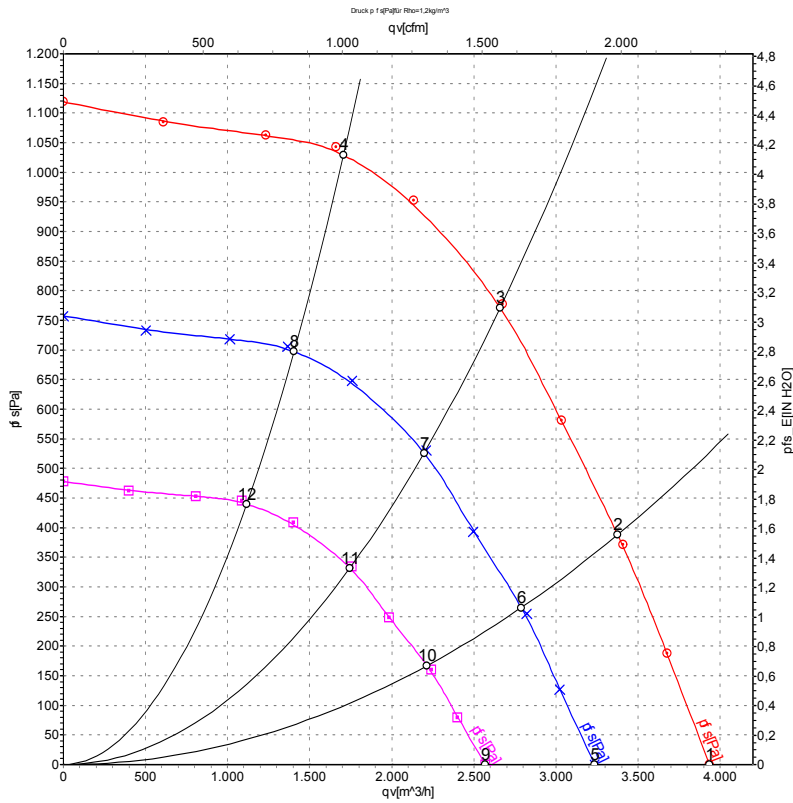

Measurement: LU-130335

Air performance measured as per ISO 5801 Installation category A. For detailed information on the measuring set-up, please contact ebmpapst. Suction-side noise levels: LwA measured as per ISO 13347 / LpA measured with 1m distance to fan axis. The values given are valid under the measuring conditions mentioned above and may vary according to the actual installation situation. With any deviation from the standard set-up, the specific values have to be checked and reviewed with the unit installed.

## Measured values

	U	f	n	P <sub>ed</sub>	I	LpA <sub>in</sub>	LwA <sub>in</sub>	LwA <sub>out</sub>	qv	p <sub>fs</sub>
	V	Hz	min <sup>-1</sup>	W	A	dB(A)	dB(A)	dB(A)	m <sup>3</sup> /h	Pa
1	400	50	3100	645	1.04	78	86	93	3935	0
2	400	50	3100	852	1.35	75	83	90	3375	390
3	400	50	3100	1000	1.60	72	80	86	2660	775
4	400	50	3100	921	1.46	76	83	89	1705	1030
5	400	50	2575	358	0.58	74	82	88	3235	0
6	400	50	2575	482	0.76	71	79	85	2790	269
7	400	50	2575	562	0.89	68	76	82	2195	534
8	400	50	2575	514	0.82	71	79	84	1405	700
9	400	50	2045	180	0.29	69	77	83	2570	0
10	400	50	2045	242	0.38	66	74	80	2215	170
11	400	50	2045	282	0.45	63	71	77	1745	337
12	400	50	2045	257	0.41	66	74	79	1115	442

U = Supply voltage · f = Frequency · n = Speed · P<sub>ed</sub> = Power input · I = Current draw · LpA<sub>in</sub> = Sound pressure level inlet side · LwA<sub>in</sub> = Sound power level inlet side · LwA<sub>out</sub> = Sound power level outlet side  
 qv = Air flow · p<sub>fs</sub> = Pressure increase

