

backward curved, single inlet

with support bracket

K3G280-AK54-21 ebmpapst Datasheet

sales@fansco.com

www.fansco.com



Nominal data

Type	K3G280-AK54-21	
Motor	M3G112-EA	
Phase		3~
Nominal voltage	VAC	400
Nominal voltage range	VAC	380 .. 480
Frequency	Hz	50/60
Type of data definition		ml
Speed	min ⁻¹	3400
Power input	W	1030
Current draw	A	1.8
Min. ambient temperature	°C	-40
Max. ambient temperature	°C	50

ml = Max. load · me = Max. efficiency · fa = Running at free air · cs = Customer specs · cu = Customer unit
Subject to alterations

Data according to ErP directive

Installation category	A
Efficiency category	Static
Variable speed drive	Yes
Specific ratio*	1.01

* Specific ratio = $1 + p_{fs} / 100\,000 \text{ Pa}$

		Actual	Request 2013	Request 2015
Overall efficiency η_{es}		52.8	47.6	51.6
Efficiency grade N		63.2	58	62
Power input P_{ed}	kW	1.02		
Air flow q_v	m ³ /h	1790		
Pressure increase p_{fs}	Pa	1003		
Speed n	min ⁻¹	3420		

Data definition with optimum efficiency.
The ErP data is determined using a motor-impeller combination in a standardised measurement configuration.



Technical features

Mass	13.7 kg
Size	280 mm
Surface of rotor	Coated in black
Material of electronics housing	Die-cast aluminium, coated in black
Material of impeller	Aluminium sheet, coated in black
Material of mounting plate	Sheet steel, galvanised and coated in black
Material of support bracket	Steel, coated in black
Material of inlet nozzle	Sheet steel, galvanised and coated in black
Number of blades	6
Direction of rotation	Clockwise, seen on rotor
Type of protection	IP 54
Insulation class	"B"
Humidity class	F4-1
Max. permissible ambient motor temp. (transp./ storage)	+80 °C
Min. permissible ambient motor temp. (transp./storage)	-40 °C
Mounting position	Refer to product drawing
Operation mode	S1
Motor bearing	Ball bearing
Technical features	<ul style="list-style-type: none"> - Output 10 VDC, max. 10 mA - Output 20 VDC, max. 50 mA - Output for slave 0-10 V - Input for sensor 0-10 V or 4-20 mA - Alarm relay - Integrated PID controller - Motor current limit - PFC, passive - RS485 ebmBUS - Soft start - Control input 0-10 VDC / PWM - Control interface with SELV potential safely disconnected from the mains - Over-temperature protected electronics / motor - Line undervoltage / phase failure detection
EMC interference immunity	Acc. to EN 61000-6-2 (industrial environment)
EMC harmonics	Acc. to EN 61000-3-2/3
EMC interference emission	Acc. to EN 61000-6-3 (household environment)
Touch current acc. IEC 60990 (measuring network Fig. 4, TN system)	<= 3.5 mA
Electrical leads	Via terminal box
Motor protection	Thermal overload protector (TOP) wired internally
Cable exit	Variable
Protection class	I (if protective earth is connected by customer)
Approval	CCC; C3

EC centrifugal module - Plug fan

backward curved, single inlet
with support bracket

Product drawing

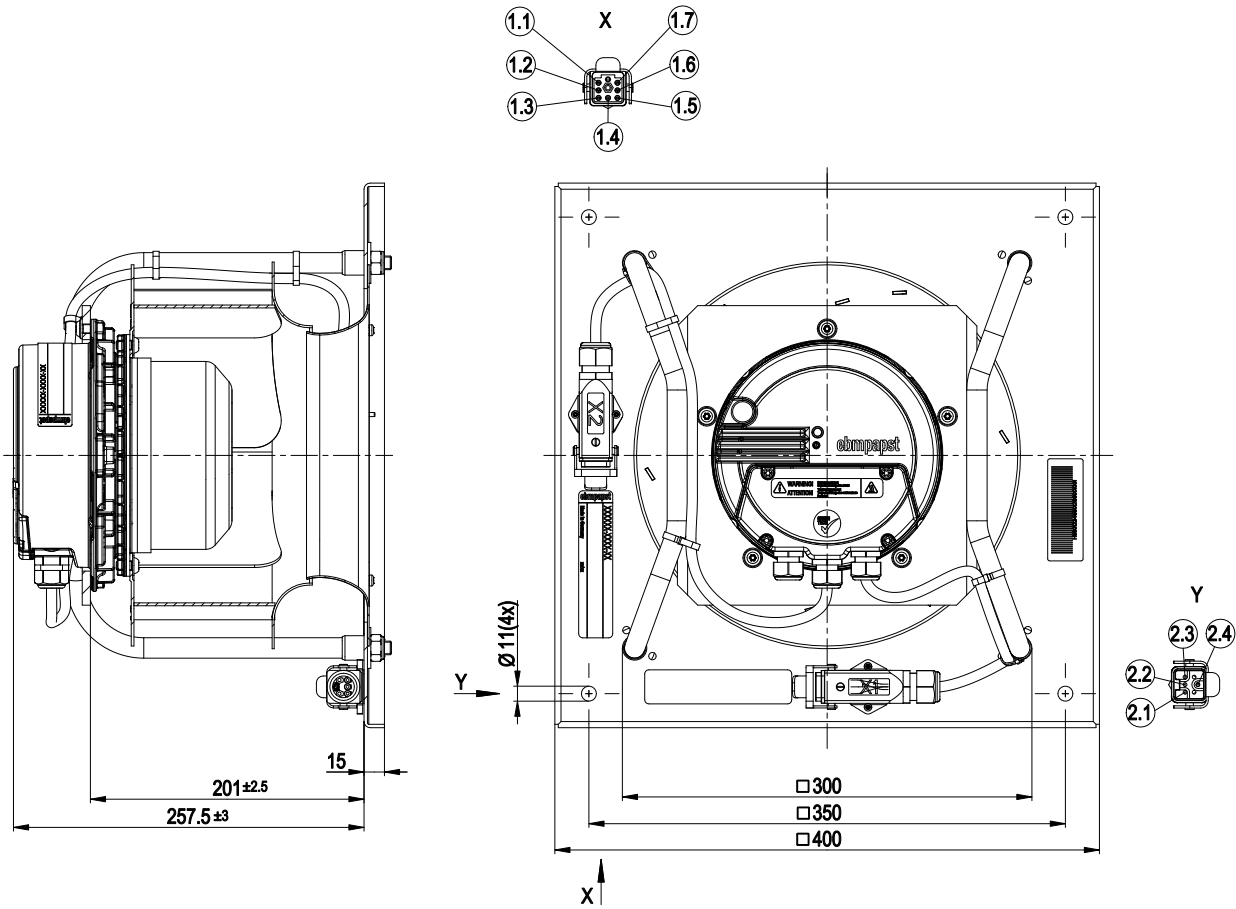

1	Connection line halogen-free with connector housing, company Harting no. 19200031250 and no. 09120053001; 7x plug pin TB09150006105
1.1	GND
1.2	0-10 V/PWM
1.3	+20 V
1.4	+10 V
1.5	NO
1.6	COM
1.7	NC
2	Connection line halogen-free with connector housing, company Harting no. 19200031250; pin insert no. 09120053001; 4x plug pin no. TB09330006104
2.1	L1
2.2	L2
2.3	L3
2.4	PE
3	Mounting position: shaft horizontal (install the support struts only vertically as shown in the view!)



Connection screen

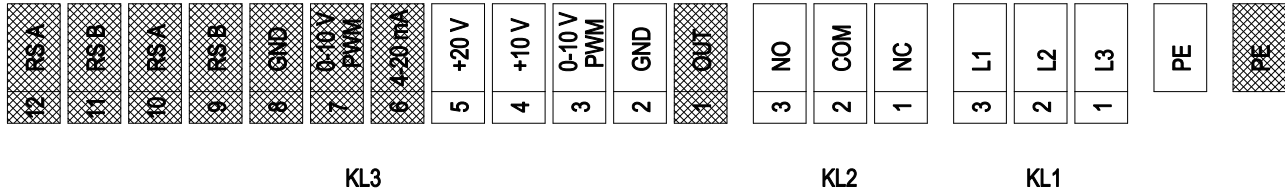

grey shaded => not brought out via leads

No.	Pin	Signal	Function / assignment
		PE	Earth connection; PE connection
1	1	L3	Mains supply connection, supply voltage 3~,380- 480 VAC; 50/60 Hz
1	2	L2	Mains supply connection, supply voltage 3~,380- 480 VAC; 50/60 Hz
1	3	L1	Mains supply connection, supply voltage 3~,380- 480 VAC; 50/60 Hz
2	1	NC	Status relay; floating status contact; normally closed for error
2	2	COM	Status relay; floating status contact; changeover contact; common connection; contact rating 250 VAC / max. 2 A (AC1) / min. 10 mA
2	3	NO	Status relay; floating status contact; normally open for error
3	1	OUT	Analogue output 0-10 V; max. 5 mA; output of the current motor level control coefficient
3	2	GND	Signal ground for control interface
3	3	0 - 10 V / PWM	Analogue input (setpoint for open-loop and closed-loop speed control / actual value for external sensor control); 0 - 10 V; Ri = 100 kΩ; can be used only as an alternative to 4 - 20 mA input
3	4	+10 V	Fixed voltage output 10 VDC; +10 V +15 %; max. 10 mA; short circuit proof; power supply for ext. devices (e.g. potentiometer)
3	5	+20 V	Fixed voltage output 20 VDC; +20 V ± 20 %; max. 50 mA; short circuit proof; power supply for ext. devices (e.g. sensors)
3	6	4 - 20 mA	Analogue input (setpoint for open-loop and closed-loop speed control / actual value for external sensor control); 4 - 20 mA; Ri = 100 Ω; can be used only as an alternative to 0 - 10 V / PWM input
3	7	0 - 10 V / PWM	Analogue input (setpoint for open-loop and closed-loop speed control / actual value for external sensor control); 0 - 10 V; Ri = 100 kΩ; electrically directly parallel to KL3.3; can be used only as an alternative to 4 - 20 mA input
3	8	GND	Signal ground for control interface
3	9	RS B	Bus connection RS485; RSB; ebm BUS
3	10	RS A	Bus connection RS485; RSA; ebm BUS
3	11	RS B	Bus connection RS485; RSB; ebm BUS; electrically directly parallel to terminal 3.9
3	12	RS A	Bus connection RS485; RSA; ebm BUS; electrically directly parallel to terminal 3.10

Charts: Air flow 50 Hz

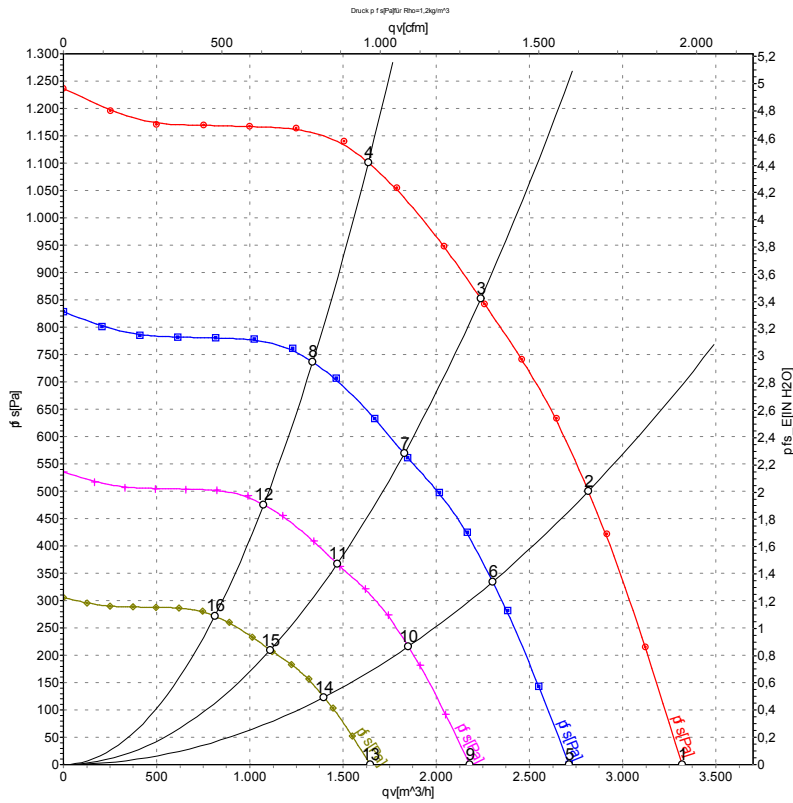

Measured values

	U	f	n	P _{ed}	I	LpA _{in}	LwA _{in}	qv	p _{fs}
	V	Hz	min ⁻¹	W	A	dB(A)	dB(A)	m ³ /h	Pa
1	400	50	3400	817	1.44	84	91	3320	0
2	400	50	3400	997	1.72	80	88	2815	500
3	400	50	3400	1030	1.80	78	86	2240	850
4	400	50	3400	980	1.69	77	84	1635	1100
5	400	50	2800	446	0.79	80	87	2715	0
6	400	50	2800	545	0.94	76	83	2305	335
7	400	50	2800	575	0.95	74	81	1830	568
8	400	50	2800	547	0.93	72	80	1335	736
9	400	50	2250	232	0.41	75	82	2180	0
10	400	50	2250	283	0.49	71	79	1850	216
11	400	50	2250	298	0.49	69	77	1470	367
12	400	50	2250	284	0.48	67	75	1075	475
13	400	50	1700	100	0.18	69	76	1645	0
14	400	50	1700	122	0.21	65	72	1400	123
15	400	50	1700	129	0.21	63	70	1110	209
16	400	50	1700	122	0.21	61	69	810	271

U = Supply voltage · f = Frequency · n = Speed · P_{ed} = Power input · I = Current draw · LpA_{in} = Sound pressure level inlet side · LwA_{in} = Sound power level inlet side · qv = Air flow
p_{fs} = Pressure increase

