

EC centrifugal module

backward curved, single inlet
with support bracket

K3G280-AK54-05 ebmpapst Datasheet
sales@fansco.com
www.fansco.com

Limited partnership · Headquarters Muldingen
County court Stuttgart · HRA 590344

General partner Elektrobau Muldingen GmbH · Headquarters Muldingen
County court Stuttgart · HRB 590142



Nominal data

Type	K3G280-AK54-05	
Motor	M3G112-EA	
Phase		3~
Nominal voltage	VAC	400
Nominal voltage range	VAC	380 .. 480
Frequency	Hz	50/60
Type of data definition		ml
Speed	min ⁻¹	3400
Power input	W	1030
Current draw	A	1.8
Min. ambient temperature	°C	-25
Max. ambient temperature	°C	50

ml = max. load · me = max. efficiency · fa = running at free air · cs = customer specs · cu = customer unit
Subject to alterations

Data according to ErP directive

Installation category	A
Efficiency category	Static
Variable speed drive	Yes
Specific ratio*	1.01

* Specific ratio = $1 + p_{fs} / 100\,000\text{ Pa}$

	Actual	Request 2013	Request 2015
Overall efficiency η_{es}	52.8	47.6	51.6
Efficiency grade N	63.2	58	62
Power input P_{ed}	kW	1.02	
Air flow q_v	m ³ /h	1790	
Pressure increase p_{fs}	Pa	1003	
Speed n	min ⁻¹	3420	

Data established at point of optimum efficiency



Technical features

Mass	13.3 kg
Size	280 mm
Material of impeller	Aluminium sheet
Material of mounting plate	Sheet steel, galvanised
Material of support bracket	Steel, coated in black
Material of inlet nozzle	Sheet steel, galvanised
Number of blades	6
Direction of rotation	Clockwise, seen on rotor
Type of protection	IP 54
Insulation class	"B"
Humidity class	F4-1
Max. permissible ambient motor temp. (transp./ storage)	+80 °C
Min. permissible ambient motor temp. (transp./storage)	-40 °C
Mounting position	Refer to product drawing
Condensate discharge holes	Rotor-side
Operation mode	S1
Motor bearing	Ball bearing
Technical features	<ul style="list-style-type: none"> - Output 10 VDC, max. 10 mA - Output 20 VDC, max. 50 mA - Output for slave 0-10 V - Input for sensor 0-10 V or 4-20 mA - Alarm relay - Integrated PID controller - Motor current limit - PFC, passive - RS485 ebmBUS - Soft start - Control input 0-10 VDC / PWM - Control interface with SELV potential safely disconnected from the mains - Over-temperature protected electronics / motor - Line undervoltage / phase failure detection
EMC interference immunity	Acc. to EN 61000-6-2 (industrial environment)
EMC harmonics	Acc. to EN 61000-3-2/3
EMC interference emission	Acc. to EN 61000-6-3 (household environment)
Touch current acc. IEC 60990 (measuring network Fig. 4, TN system)	<= 3.5 mA
Electrical leads	Via terminal box
Motor protection	Thermal overload protector (TOP) wired internally
Cable exit	Variable
Protection class	I (if protective earth is connected by customer)
Product conforming to standard	EN 61800-5-1; CE

EC centrifugal module

backward curved, single inlet
with support bracket

Product drawing

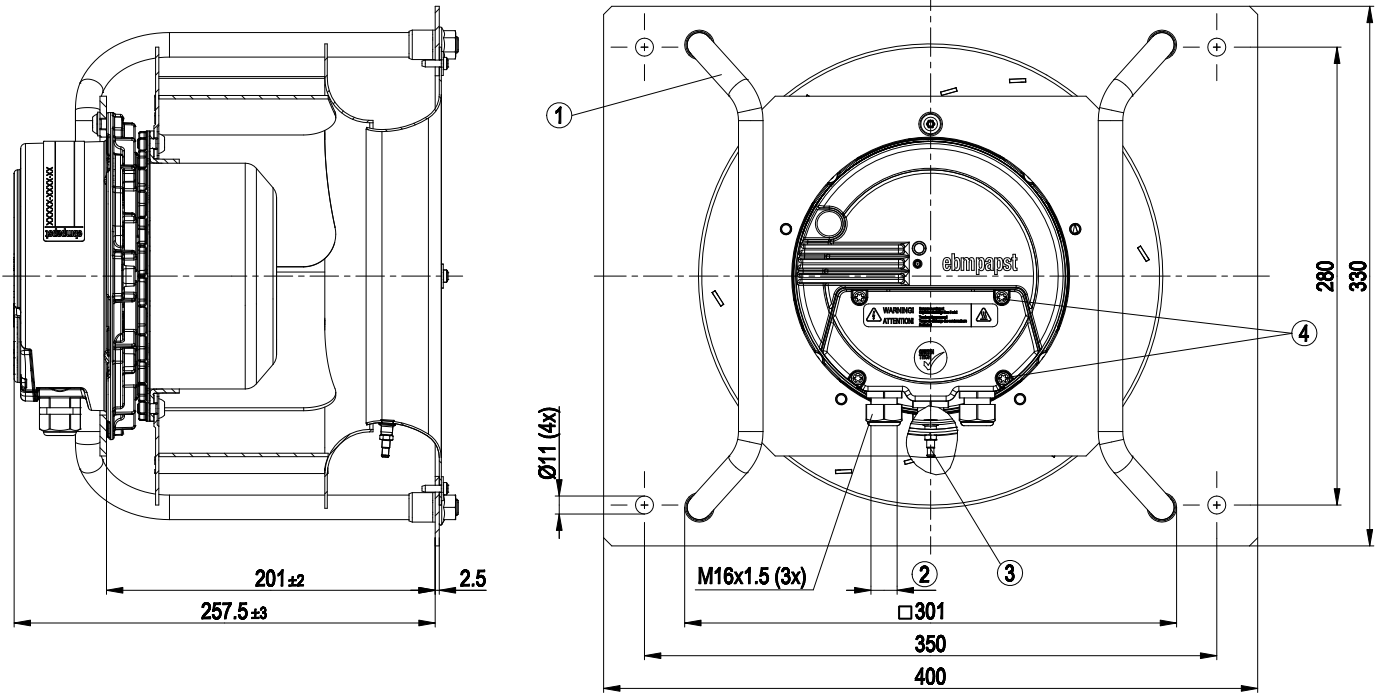

1	Mounting position: shaft horizontal (install the support struts only vertically as shown in the view!) or rotor on bottom; rotor on top on request
2	Cable diameter: min. 4 mm, max. 10 mm; tightening torque: 2.5±0.4 Nm
3	Inlet nozzle with bleeder connection for pressure relief (k-factor: 116)
4	Tightening torque 3.5±0.5 Nm



EC centrifugal module

backward curved, single inlet
with support bracket

Connection screen

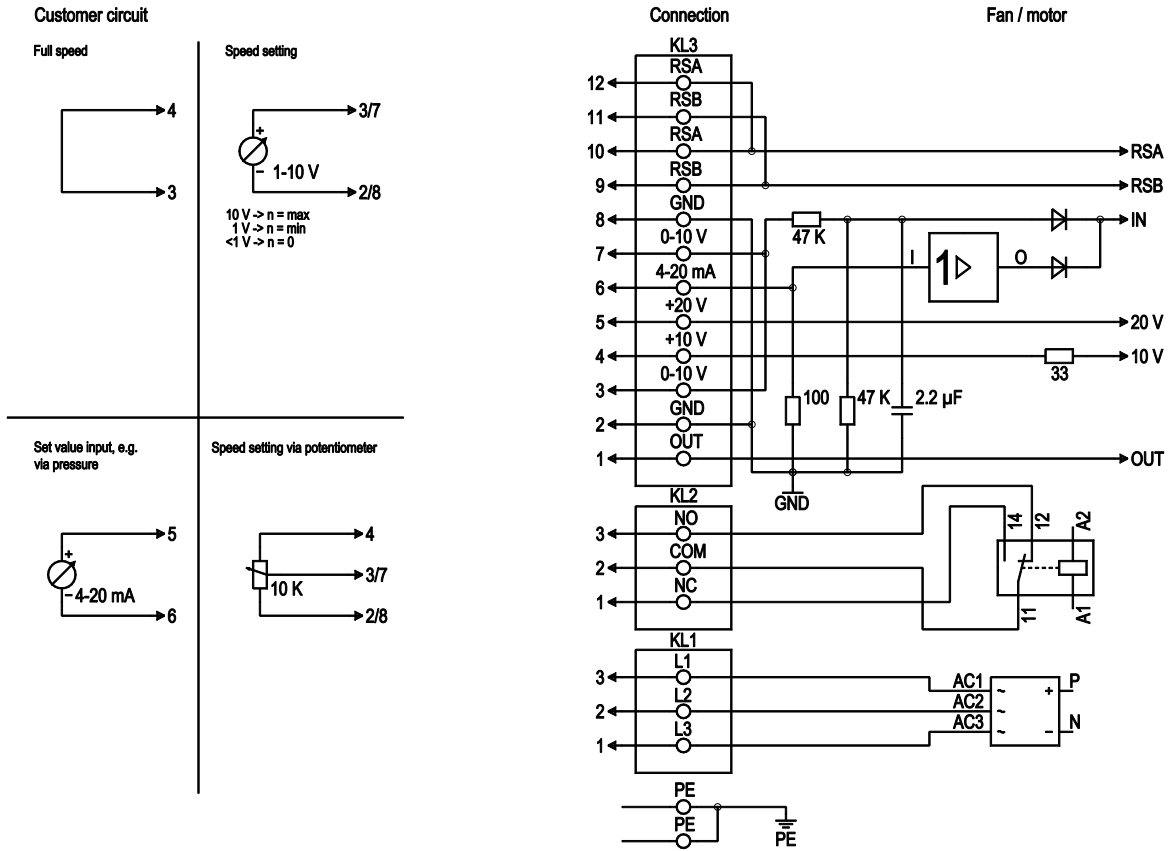

No.	Pin	Signal	Function / assignment
PE		PE	Protective earth connection
KL1	1, 2, 3	L1, L2, L3	Supply voltage, 50/60 Hz
KL2	1	NC	Floating status message contact, normally closed connection; break for failure
KL2	2	COM	Floating status message contact, changeover contact, common connection (2 A, max. 250 VAC, min. 10 mA, AC1)
KL2	3	NO	Floating status message contact, normally open connection; make for failure
KL3	1	OUT	Analog output, 0-10 VDC, max. 3 mA, SELV, output of the current level control coefficient: 1 V equates to 10% level control coefficient. 10 V equate to 100% level control coefficient.
KL3	2, 8	GND	Reference mass for control interface, SELV
KL3	3, 7	0-10 V	Use control / actual value input 0-10 VDC, impedance 100 kΩ only as alternative to 4-20 mA input, SELV
KL3	4	+10 V	Voltage output 10 VDC (+/-3%), max. 10 mA, supply voltage for external devices (e.g. potentiometers), SELV
KL3	5	+20 V	Voltage output 20 VDC (+25%/-10%), max. 50 mA, supply voltage for external devices (e.g. sensors), SELV
KL3	6	4-20 mA	Use control / actual value input 4-20 mA, impedance 100 Ω, only as alternative to 0-10 V input, SELV
KL3	9, 11	RSB	RS485 interface for ebmBus, RSB, SELV
KL3	10, 12	RSA	RS485 interface for ebmBus, RSA, SELV



Charts: Air flow 50 Hz

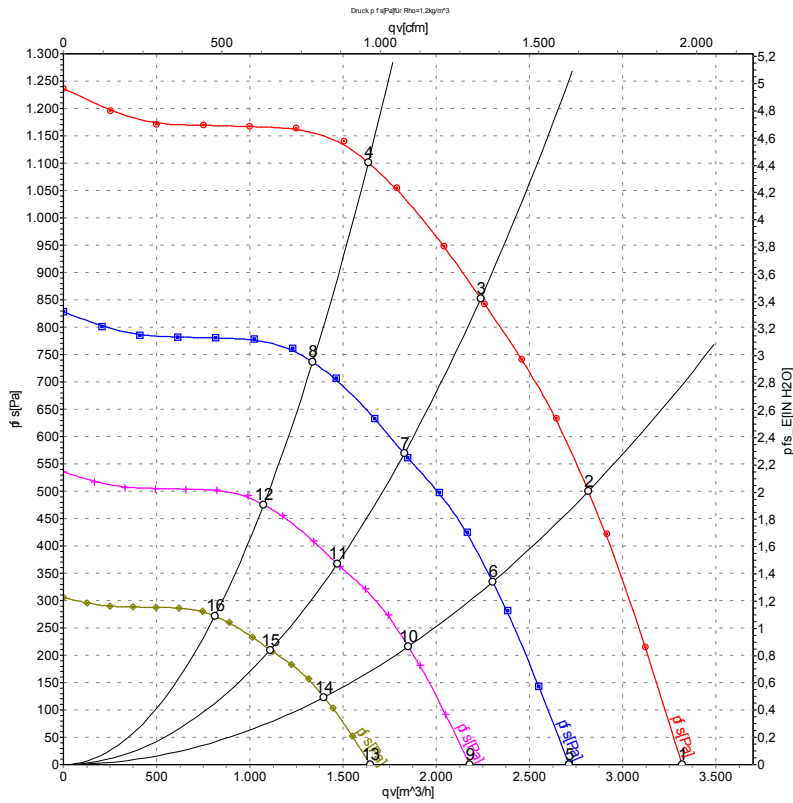

Measurement: LU-114283

Air performance measured as per ISO 5801 Installation category A. For detailed information on the measuring set-up, please contact ebm-papst. Suction-side noise levels: LwA measured as per ISO 13347 / LpA measured with 1m distance to fan axis. The values given are valid under the measuring conditions mentioned above and may vary according to the actual installation situation. With any deviation from the standard set-up, the specific values have to be checked and reviewed with the unit installed.

Measured values

	U	f	n	P _{ed}	I	LpA _{in}	LwA _{in}	qv	ps
	V	Hz	min ⁻¹	W	A	dB(A)	dB(A)	m ³ /h	Pa
1	400	50	3400	817	1.44	84	91	3320	0
2	400	50	3400	997	1.72	80	88	2815	500
3	400	50	3400	1030	1.80	78	86	2240	850
4	400	50	3400	980	1.69	77	84	1635	1100
5	400	50	2800	446	0.79	80	87	2715	0
6	400	50	2800	545	0.94	76	83	2305	335
7	400	50	2800	575	0.95	74	81	1830	568
8	400	50	2800	547	0.93	72	80	1335	736
9	400	50	2250	232	0.41	75	82	2180	0
10	400	50	2250	283	0.49	71	79	1850	216
11	400	50	2250	298	0.49	69	77	1470	367
12	400	50	2250	284	0.48	67	75	1075	475
13	400	50	1700	100	0.18	69	76	1645	0
14	400	50	1700	122	0.21	65	72	1400	123
15	400	50	1700	129	0.21	63	70	1110	209
16	400	50	1700	122	0.21	61	69	810	271

U = Supply voltage · f = Frequency · n = Speed · P_{ed} = Power input · I = Current draw · LpA_{in} = Sound pressure level inlet side · LwA_{in} = Sound power level inlet side · qv = Air flow
 ps = Pressure increase

