

K3G250-RR01-H3

EC centrifugal module - RadiCal

backward curved, single inlet

with support bracket



K3G250-RR01-H3 ebmpapst Datasheet

sales@fansco.com

www.fansco.com

Limited partnership · Headquarters Mulfingen
County court Stuttgart · HRA 590344

General partner Elektrobau Mulfingen GmbH · Headquarters Mulfingen
County court Stuttgart · HRB 590142

Nominal data

Type	K3G250-RR01-H3	
Motor	M3G084-DF	
Phase		1~
Nominal voltage	VAC	230
Nominal voltage range	VAC	200 .. 277
Frequency	Hz	50/60
Type of data definition		ml
Speed (rpm)	min ⁻¹	3740
Power input	W	500
Current draw	A	2.2
Min. ambient temperature	°C	-25
Max. ambient temperature	°C	60

ml = Max. load · me = Max. efficiency · fa = Running at free air · cs = Customer specs · cu = Customer unit
Subject to alterations

Data according to ErP directive

		Actual	Request 2015
01 Overall efficiency η_{es}	%	60.1	48.3
02 Measurement category		A	
03 Efficiency category		Static	
04 Efficiency grade N		73.8	62
05 Variable speed drive		Yes	

Data definition with optimum efficiency.
The ErP data is determined using a motor-impeller combination in a standardised measurement configuration.

09 Power input P_{ed}	kW	0.5
09 Air flow q_v	m ³ /h	1355
09 Pressure increase p_{fs}	Pa	733
10 Speed (rpm) n	min ⁻¹	3735
11 Specific ratio*		1.01

* Specific ratio = $1 + p_{fs} / 100\,000\text{ Pa}$

LU-151690



backward curved, single inlet
with support bracket

Technical features

Mass	8 kg
Size	250 mm
Surface of rotor	Coated in black
Material of electronics housing	Die-cast aluminium
Material of impeller	PA plastic
Material of mounting plate	Sheet steel, galvanised
Material of support bracket	Steel, coated in black
Material of inlet nozzle	Sheet steel, galvanised
Number of blades	7
Direction of rotation	Clockwise, seen on rotor
Type of protection	IP 55
Insulation class	"F"
Humidity (F)/environmental protection class (H)	F3-1
Max. permissible ambient motor temp. (transp./ storage)	+80 °C
Min. permissible ambient motor temp. (transp./storage)	-40 °C
Mounting position	Shaft horizontal or rotor on bottom; rotor on top on request
Condensate discharge holes	Rotor-side
Operation mode	S1
Motor bearing	Ball bearing
Technical features	<ul style="list-style-type: none"> - Output 10 VDC, max. 10 mA - Operation and alarm display - Alarm relay - Integrated PID controller - Output limit - Motor current limit - PFC, active - RS485 MODBUS RTU - Soft start - Control input 0-10 VDC / PWM - Control interface with SELV potential safely disconnected from the mains - Over-temperature protected electronics / motor - Line undervoltage / phase failure detection
EMC interference immunity	Acc. to EN 61000-6-2 (industrial environment)
EMC harmonics	Acc. to EN 61000-3-2/3
EMC interference emission	Acc. to EN 61000-6-3 (household environment)
Touch current acc. IEC 60990 (measuring network Fig. 4, TN system)	<= 3.5 mA
Motor protection	Thermal overload protector (TOP) wired internally
Cable exit	Variable
Protection class	I (if protective earth is connected by customer)
Product conforming to standard	EN 61800-5-1; EN 60335-1; CE
Approval	C22.2 Nr.77 + CAN/CSA-E60730-1; UL 1004-7 + 60730; EAC



EC centrifugal module - RadiCal

backward curved, single inlet
with support bracket

Product drawing

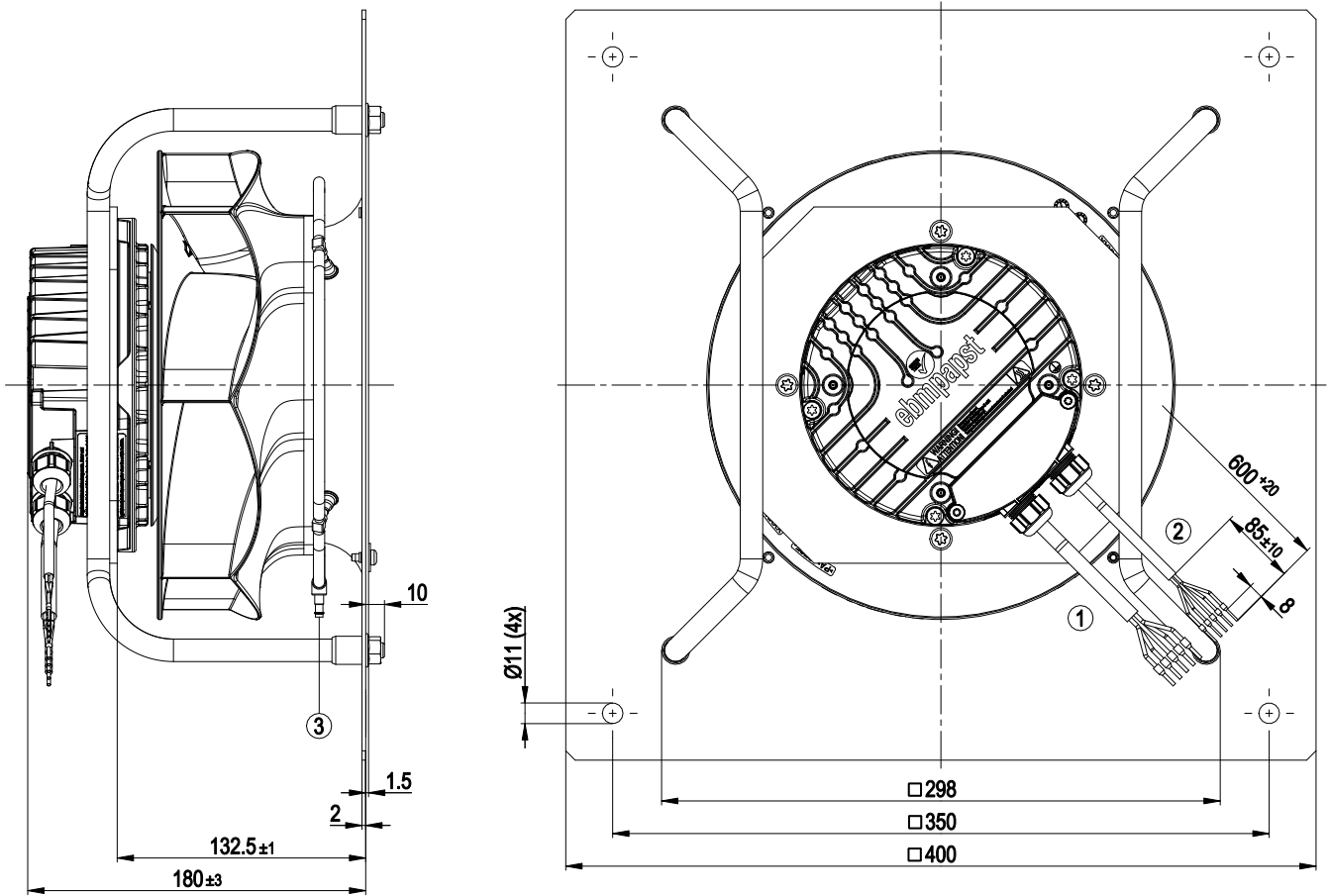

- | | |
|---|--|
| 1 | Connection line PVC AWG18, 5x crimped core-end sleeves |
| 2 | Connection line PVC AWG22, 5x crimped core-end sleeves |
| 3 | Inlet nozzle with ring line (k-factor: 60) |



EC centrifugal module - RadiCal

backward curved, single inlet
with support bracket

Connection screen

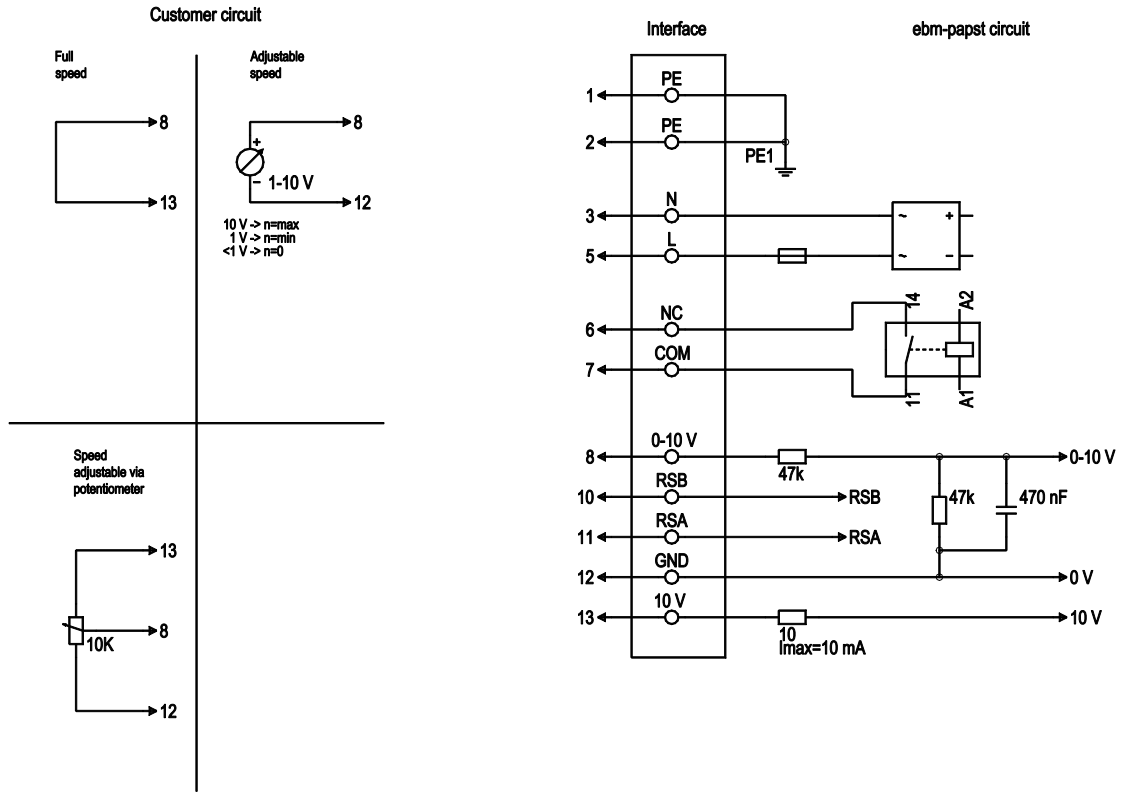

No.	Conn.	Designation	Colour	Function / assignment
1	1, 2	PE	green/yellow	Protective earth
1	3	N	blue	Supply voltage, neutral conductor, 50/60 Hz
1	5	L	black	Supply voltage, phase, 50/60 Hz
1	6	NC	white 1	Status relay, floating status contact; break for failure, contact rating 250 VAC / 2A (AC1) min. 10 mA, basic insulation on mains side and reinforced insulation on control interface side
1	7	COM	white 2	Status relay, floating status contact; common connection, contact rating 250 VAC / 2A (AC1) min. 10 mA, basic insulation on mains side and reinforced insulation on control interface side
2	8	0-10V	yellow	Analogue input 1 (set value); 0-10 V; Ri=100kΩ; parametrisable curve
2	10	RSB	brown	RS485 interface for Modbus, RSB
2	11	RSA	white	RS485 interface for Modbus, RSA
2	12	GND	blue	Reference ground for control interface, SELV
2	13	+10V	red	Fixed voltage output 10 VDC; +10 V +/-3%; max. 10 mA; short-circuit-proof; power supply for external devices (e.g. potentiometer)



Charts: Air flow 50 Hz

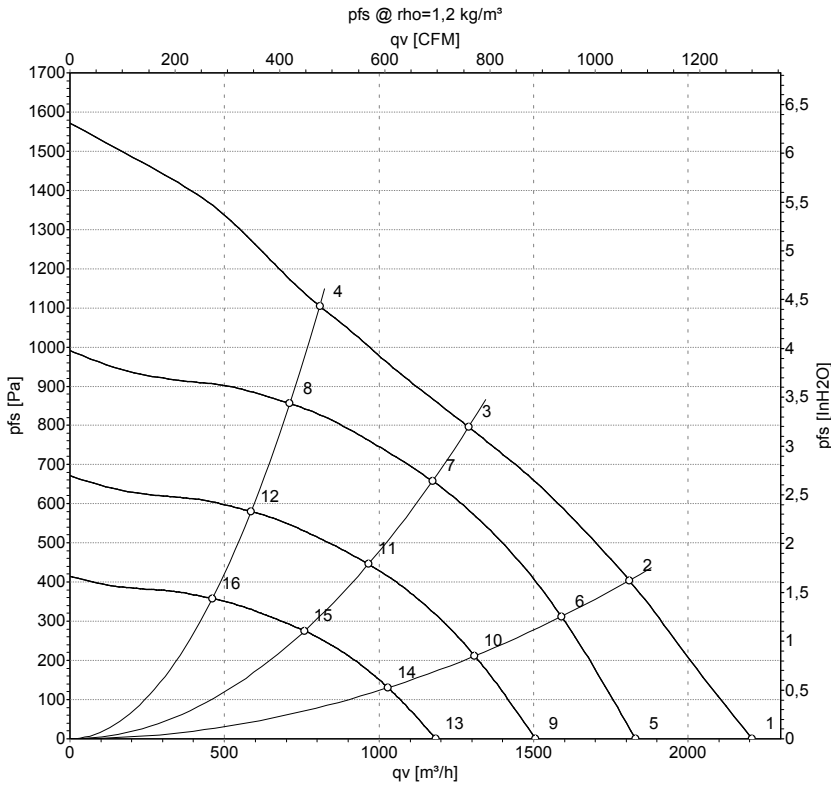

Measurement: LU-151690-1

Air performance measured as per ISO 5801 Installation category A. For detailed information on the measuring set-up, please contact ebmpapst. Suction-side noise levels: LwA measured as per ISO 13347 / LpA measured with 1m distance to fan axis. The values given are valid under the measuring conditions mentioned above and may vary according to the actual installation situation. With any deviation from the standard set-up, the specific values have to be checked and reviewed with the unit installed.

Measured values

	U	f	n	P _{ed}	I	LpA _{in}	LwA _{in}	q _v	P _{fs}	q _v	P _{fs}
	V	Hz	min ⁻¹	W	A	dB(A)	dB(A)	m ³ /h	Pa	cfm	inH2O
1	230	50	4100	500	2.20	81	89	2210	0	1300	0.00
2	230	50	3870	500	2.20	75	83	1810	400	1065	1.61
3	230	50	3740	500	2.20	70	78	1290	800	760	3.21
4	230	50	3860	500	2.20	77	84	810	1100	475	4.42
5	230	50	3400	292	1.27	76	84	1830	0	1075	0.00
6	230	50	3400	346	1.51	72	80	1590	313	935	1.26
7	230	50	3400	383	1.67	68	75	1175	658	690	2.64
8	230	50	3400	348	1.52	74	81	710	856	420	3.44
9	230	50	2800	163	0.71	71	79	1505	0	885	0.00
10	230	50	2800	193	0.84	67	75	1310	212	770	0.85
11	230	50	2800	214	0.93	63	71	965	446	570	1.79
12	230	50	2800	194	0.85	69	76	585	580	345	2.33
13	230	50	2200	79	0.35	65	73	1185	0	695	0.00
14	230	50	2200	94	0.41	61	69	1030	131	605	0.53
15	230	50	2200	104	0.45	57	65	760	276	445	1.11
16	230	50	2200	94	0.41	63	70	460	358	270	1.44

U = Supply voltage · f = Frequency · n = Speed (rpm) · P_{ed} = Power input · I = Current draw · LpA_{in} = Sound pressure level inlet side · LwA_{in} = Sound power level inlet side · q_v = Air flow
P_{fs} = Pressure increase

