

backward curved, single inlet

with housing

K3G250-RE07-17 ebmpapst Datasheet

sales@fansco.com

www.fansco.com

Limited partnership · Headquarters Muldingen
County court Stuttgart · HRA 590344

General partner Elektrobau Muldingen GmbH · Headquarters Muldingen
County court Stuttgart · HRB 590142

Nominal data

Type	K3G250-RE07-17	
Motor	M3G055-DF	
Phase		1~
Nominal voltage	VAC	230
Nominal voltage range	VAC	200 .. 240
Frequency	Hz	50/60
Type of data definition		ml
Speed (rpm)	min ⁻¹	2510
Power input	W	170
Current draw	A	1.4
Min. ambient temperature	°C	-25
Max. ambient temperature	°C	60

ml = Max. load · me = Max. efficiency · fa = Running at free air · cs = Customer specs · cu = Customer unit
Subject to alterations

Data according to ErP directive

		Actual	Request 2015			
01 Overall efficiency η_{es}	%	57.8	43.1	09 Power input P_{ed}	kW	0.16
02 Measurement category		A		09 Air flow q_v	m ³ /h	800
03 Efficiency category		Static		09 Pressure increase p_{fs}	Pa	380
04 Efficiency grade N		76.7	62	10 Speed (rpm) n	min ⁻¹	2535
05 Variable speed drive		Yes		11 Specific ratio [*]		1.00

Data definition with optimum efficiency.

The ErP data is determined using a motor-impeller combination in a standardised measurement configuration.

^{*} Specific ratio = $1 + p_{fs} / 100\,000\text{ Pa}$

LU-153273



backward curved, single inlet
with housing

Technical features

Mass	2.7 kg
Size	250 mm
Surface of rotor	Thick layer passivated
Material of impeller	PA plastic
Housing material	PA plastic
Number of blades	7
Direction of rotation	Clockwise, seen on rotor
Type of protection	IP 54
Insulation class	"B"
Max. permissible ambient motor temp. (transp./ storage)	+ 80 °C
Min. permissible ambient motor temp. (transp./storage)	- 40 °C
Mounting position	Any
Condensate discharge holes	None, open rotor
Operation mode	S1
Motor bearing	Ball bearing
Technical features	<ul style="list-style-type: none"> - Tach output - Output limit - Motor current limit - Soft start - Control input 0-10 VDC / PWM - Control interface with SELV potential safely disconnected from the mains - Overvoltage detection - Over-temperature protected electronics / motor - Line undervoltage detection
Touch current acc. IEC 60990 (measuring network Fig. 4, TN system)	<= 3.5 mA
Motor protection	Locked-rotor protection
Cable exit	Variable
Protection class	I (if protective earth is connected by customer)
Product conforming to standard	EN 60335-1; CE
Approval	CCC; C22.2 Nr.77 + CAN/CSA-E60730-1; UL 1004-7 + 60730



Product drawing

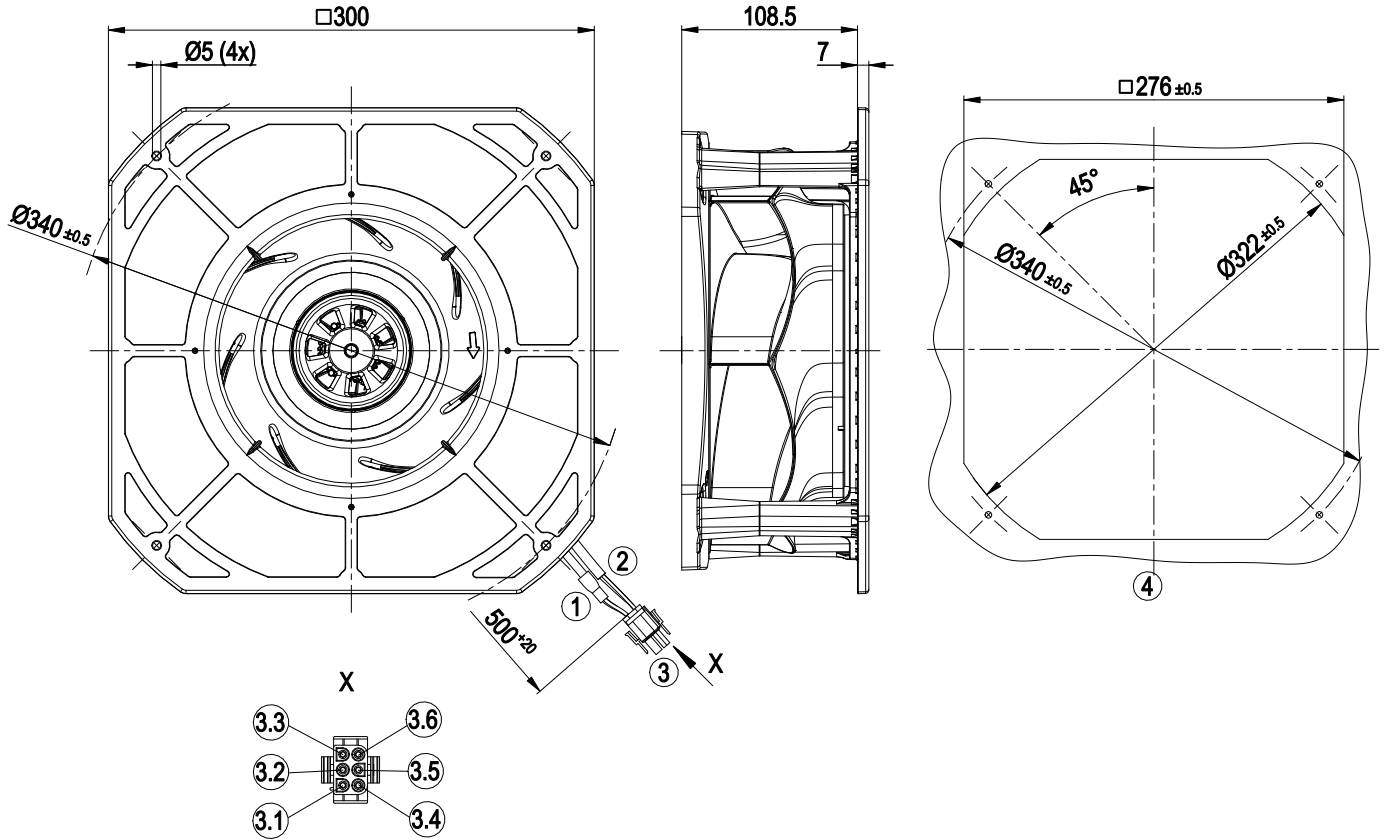

1	Connection line PVC AWG20, 3x plug pin tyco 350218-6
2	Connection line PVC AWG22, 3x plug pin tyco 350561-7
3	6-pole connector housing tyco 1-1644053-3
3.1	L (black)
3.2	N (blue)
3.3	PE (green/yellow)
3.4	0-10 V PWM (yellow)
3.5	GND (blue)
3.6	Tach (white)
4	Mounting dimensions



EC centrifugal module - RadiCal

backward curved, single inlet
with housing

Connection screen

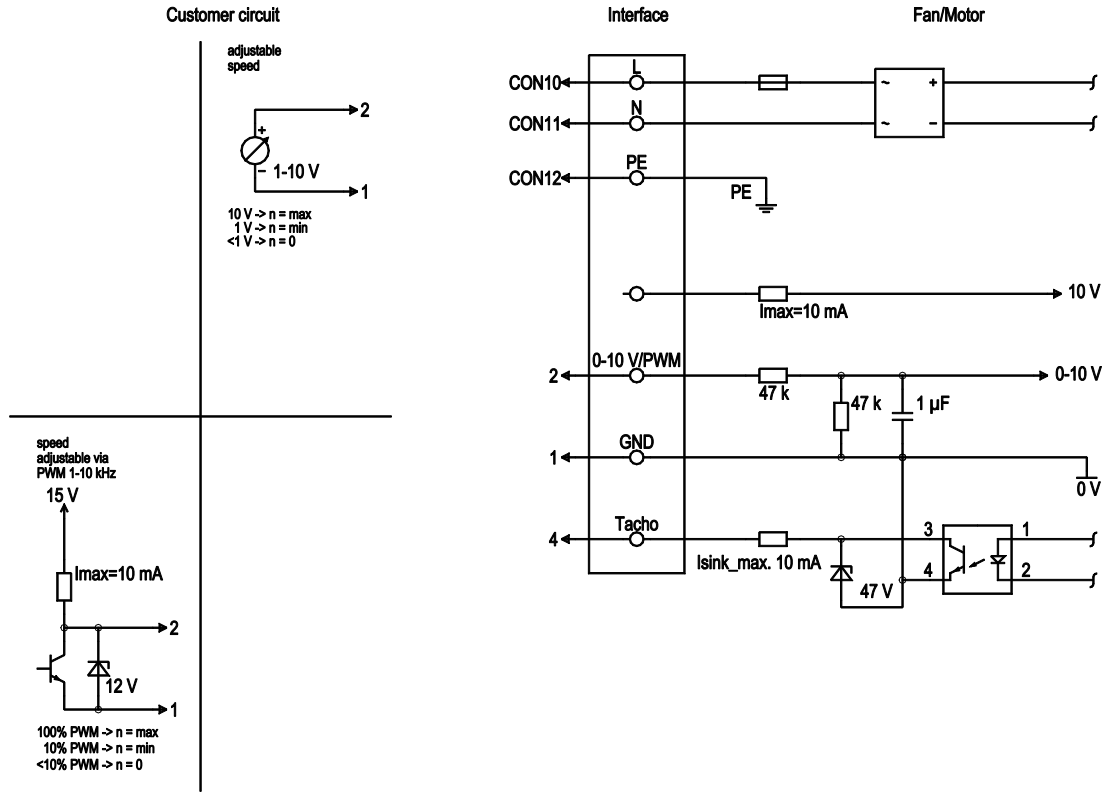

No.	Conn.	Designation	Colour	Function / assignment
	CON10	L	black	Mains connection, power supply, phase, see type plate for voltage range
	CON11	N	blue	Mains connection, power supply, neutral conductor, see type plate for voltage range
	CON12	PE	green/yellow	Earth connection
	2	0- 10V PWM	yellow	0-10 V/PWM control input, R _i =100 kΩ, SELV
	4	Tach	white	Speed monitoring output, open collector, 1 pulse per revolution, I _{sink max} = 10 mA, SELV
	1	GND	blue	Signal ground for control interface, SELV



EC centrifugal module - RadiCal

backward curved, single inlet
with housing

Charts: Air flow 50 Hz

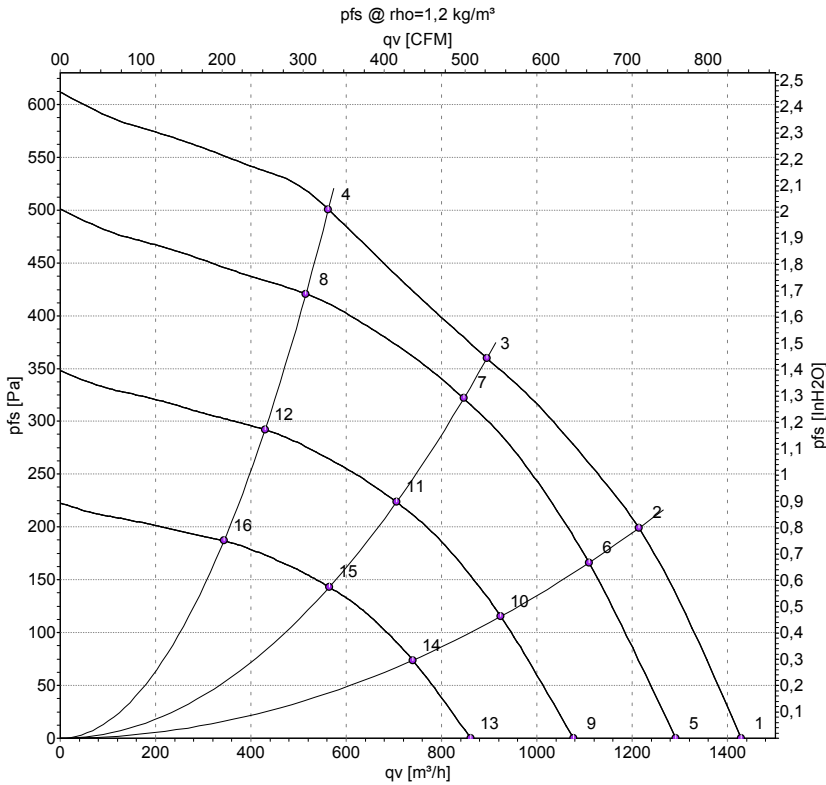

Measurement: LU-154717-1

Air performance measured as per ISO 5801 Installation category A. For detailed information on the measuring set-up, please contact ebm-papst. Suction-side noise levels: LwA measured as per ISO 13347 / LpA measured with 1m distance to fan axis. The values given are valid under the measuring conditions mentioned above and may vary according to the actual installation situation. With any deviation from the standard set-up, the specific values have to be checked and reviewed with the unit installed.

Measured values

	U	f	n	P _{ed}	I	LpA _{in}	LwA _{in}	q _v	P _{fs}	q _v	P _{fs}
	V	Hz	min ⁻¹	W	A	dB(A)	dB(A)	m ³ /h	Pa	cfm	inH2O
1	230	50	2655	143	1.18	68	76	1430	0	840	0.00
2	230	50	2630	170	1.40	64	72	1215	200	715	0.80
3	230	50	2510	170	1.40	60	67	895	360	525	1.45
4	230	50	2620	168	1.39	65	73	560	500	330	2.01
5	230	50	2400	105	0.87	66	73	1290	0	760	0.00
6	230	50	2400	129	1.07	62	69	1110	168	655	0.67
7	230	50	2400	144	1.19	59	66	845	322	500	1.29
8	230	50	2400	129	1.07	63	70	515	421	305	1.69
9	230	50	2000	61	0.51	61	69	1075	0	635	0.00
10	230	50	2000	75	0.62	57	65	925	116	545	0.47
11	230	50	2000	83	0.69	54	62	705	224	415	0.90
12	230	50	2000	75	0.62	59	66	430	292	250	1.17
13	230	50	1600	31	0.26	55	63	860	0	505	0.00
14	230	50	1600	38	0.32	52	59	740	75	435	0.30
15	230	50	1600	43	0.35	48	56	565	143	330	0.57
16	230	50	1600	38	0.32	53	60	345	187	200	0.75

U = Supply voltage · f = Frequency · n = Speed (rpm) · P_{ed} = Power input · I = Current draw · LpA_{in} = Sound pressure level inlet side · LwA_{in} = Sound power level inlet side · q_v = Air flow
P_{fs} = Pressure increase

