

K3G200-AD11-02

EC diagonal module

single inlet
with housing



K3G200-AD11-02 ebmpapst Datasheet
sales@fansco.com
www.fansco.com

Limited partnership · Headquarters Muldingen
County court Stuttgart · HRA 590344

General partner Elektrobau Muldingen GmbH · Headquarters Muldingen
County court Stuttgart · HRB 590142

Nominal data

Type	K3G200-AD11-02	
Motor	M3G055-BI	
Phase		1~
Nominal voltage	VAC	115
Nominal voltage range	VAC	100 .. 130
Frequency	Hz	50/60
Type of data definition		ml
Speed (rpm)	min ⁻¹	2850
Power input	W	65
Current draw	A	1.0
Max. back pressure	Pa	180
Min. ambient temperature	°C	-25
Max. ambient temperature	°C	60

ml = Max. load · me = Max. efficiency · fa = Running at free air · cs = Customer specs · cu = Customer unit
Subject to alterations



Technical features

Mass	2 kg
Size	200 mm
Surface of rotor	Thick layer passivated
Material of terminal box	PA plastic
Material of electronics housing	Die-cast aluminium
Material of impeller	PA plastic
Housing material	PP plastic
Number of blades	7
Direction of rotation	Clockwise, seen on rotor
Type of protection	IP 54
Insulation class	"B"
Humidity (F)/environmental protection class (H)	H0 - dry environment
Max. permissible ambient motor temp. (transp./ storage)	+ 80 °C
Min. permissible ambient motor temp. (transp./storage)	- 40 °C
Mounting position	Any
Condensate discharge holes	None, open rotor
Operation mode	S1
Motor bearing	Ball bearing
Technical features	<ul style="list-style-type: none"> - Output 10 VDC, max. 1.1 mA - Tach output - Output limit - Motor current limit - Soft start - Control input 0-10 VDC / PWM - Control interface with SELV potential safely disconnected from the mains - Over-temperature protected electronics / motor
EMC interference immunity	Acc. to EN 61000-6-2 (industrial environment)
EMC interference emission	Acc. to EN 61000-6-4 (industrial environment)
Touch current acc. IEC 60990 (measuring network Fig. 4, TN system)	<= 3.5 mA
Motor protection	Locked-rotor protection
Cable exit	Variable
Protection class	I (if protective earth is connected by customer)
Product conforming to standard	EN 60335-1; CE
Approval	UL 1004-7 + 60730; C22.2 Nr.77 + CAN/CSA-E60730-1

EC diagonal module

single inlet
with housing

Product drawing

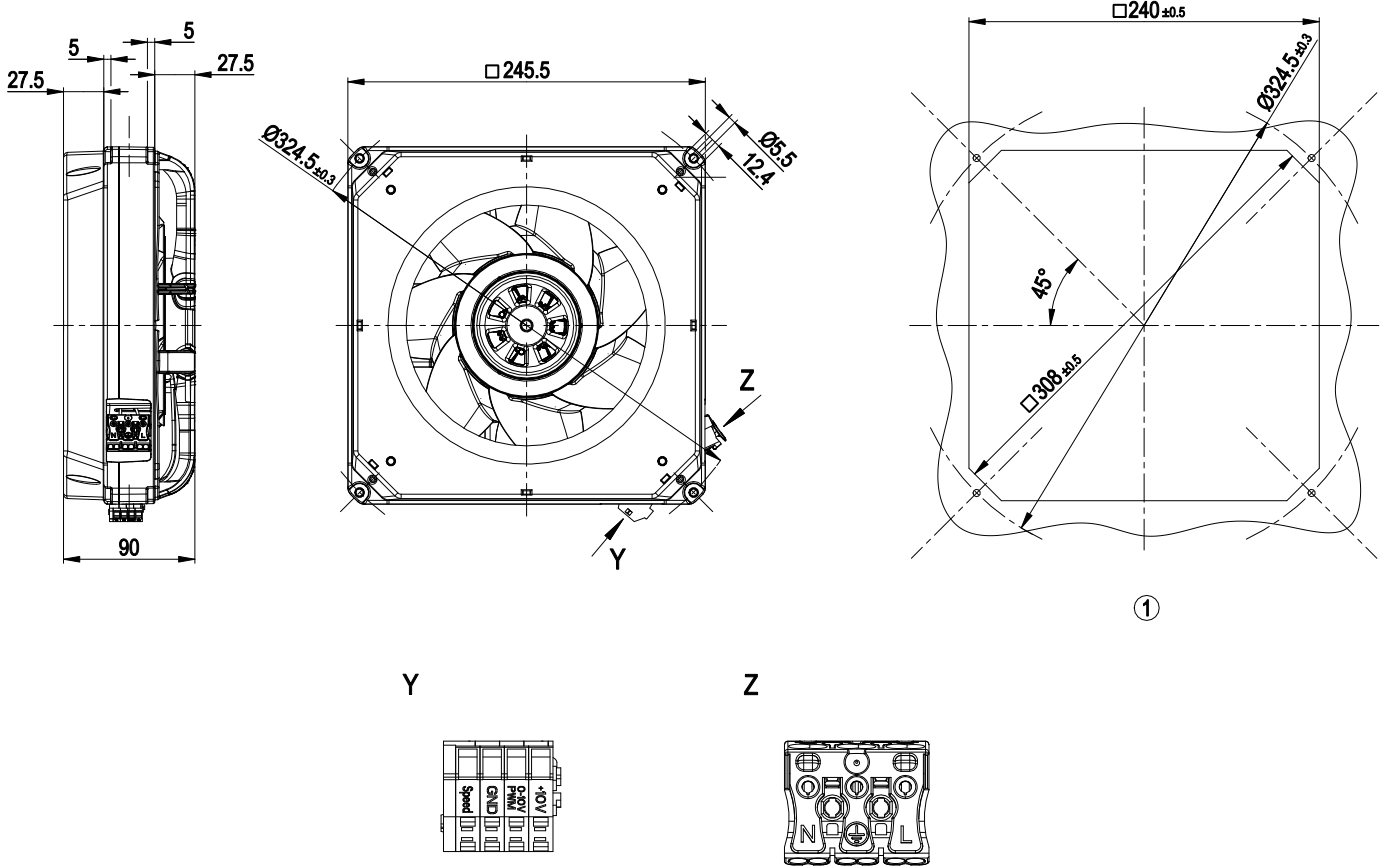

1 Mounting dimensions



EC diagonal module

single inlet
with housing

Accessory part

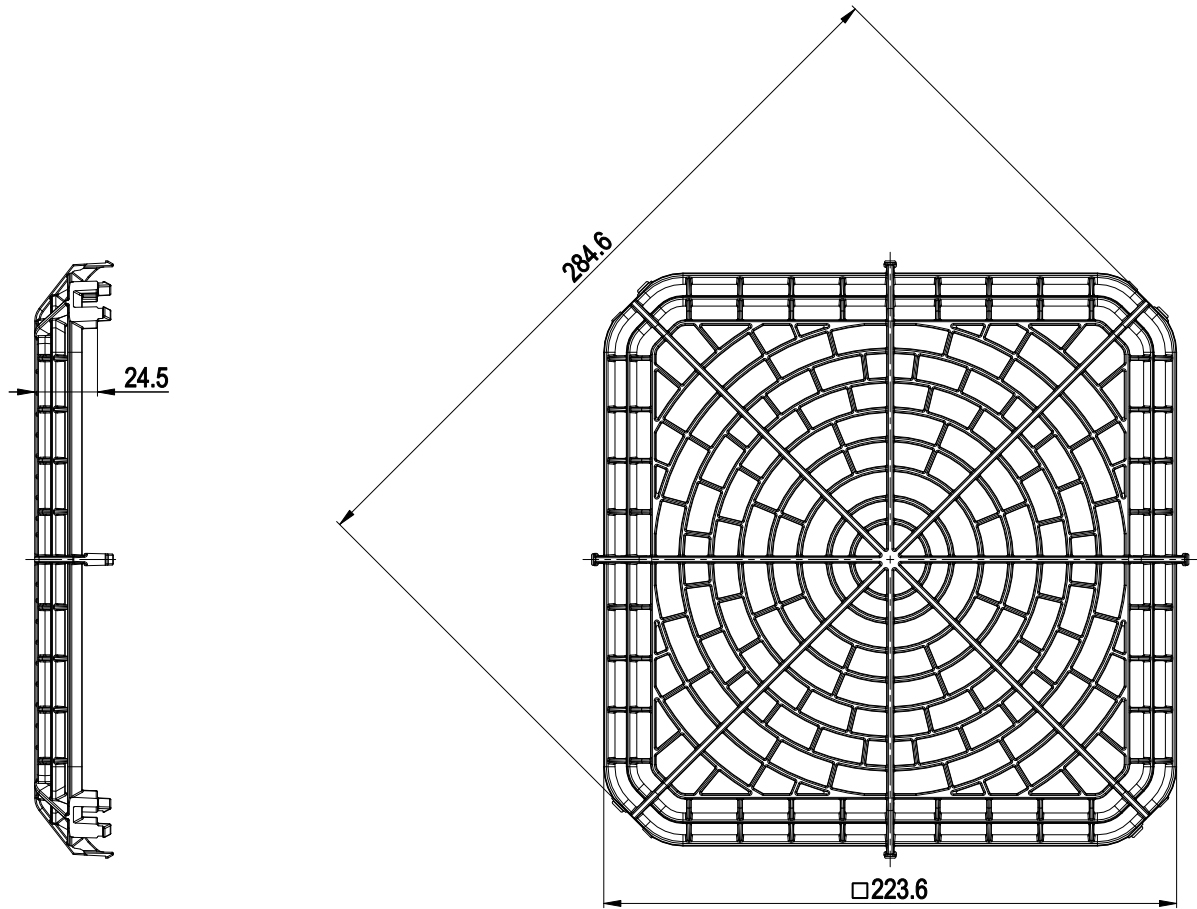

Accessory part: Guard grille 25000-2-2929 outlet side, not included in scope of delivery



K3G200-AD11-02

EC diagonal module

single inlet
with housing

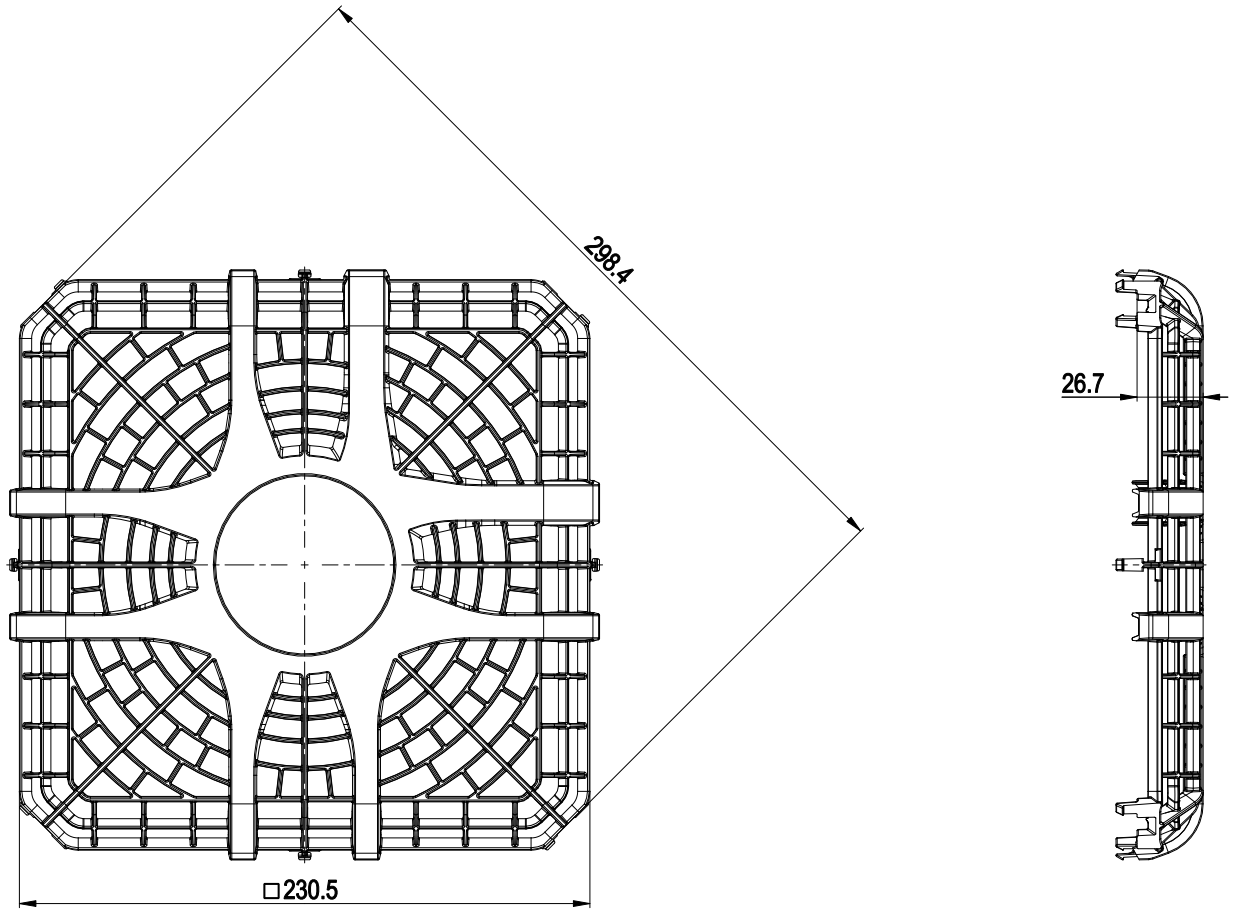

Accessory part: Guard grille 25001-2-2929 intake side, not included in scope of delivery



EC diagonal module

single inlet
with housing

Connection screen

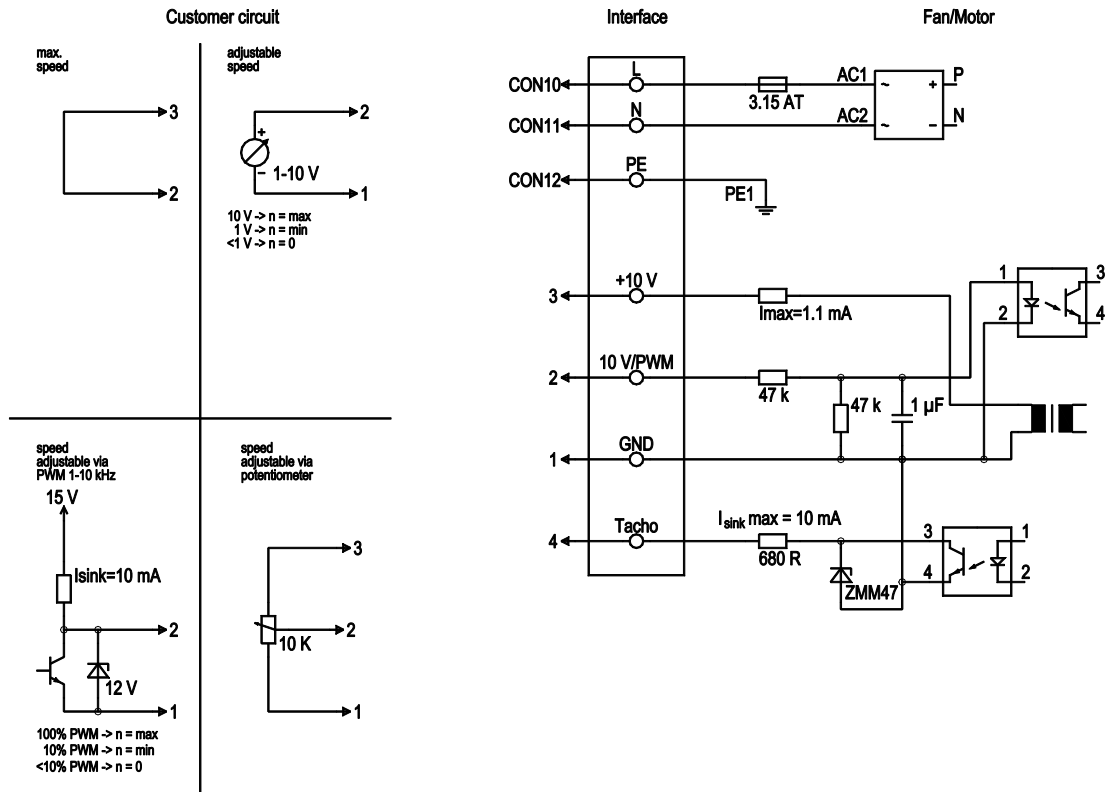

No.	Conn.	Designation	Colour	Function / assignment
	CON10	L	black	Power supply 115 VAC, 50-60 Hz, see type plate for voltage range
	CON11	N	blue	Neutral conductor
	CON12	PE	green/yellow	Protective earth
	1	GND	blue	GND connection for control interface
	2	0- 10V PWM	yellow	Control input 0-10 V or PWM, electrically isolated
	3	10V/ max 1.1mA	red	Voltage output 10 VDC 1.1 mA, electrically isolated, short-circuit-proof
	4	Tach	white	Tach output: Open collector, 1 pulse per revolution, electrically isolated, Isink max = 10 mA



Charts: Air flow 50 Hz

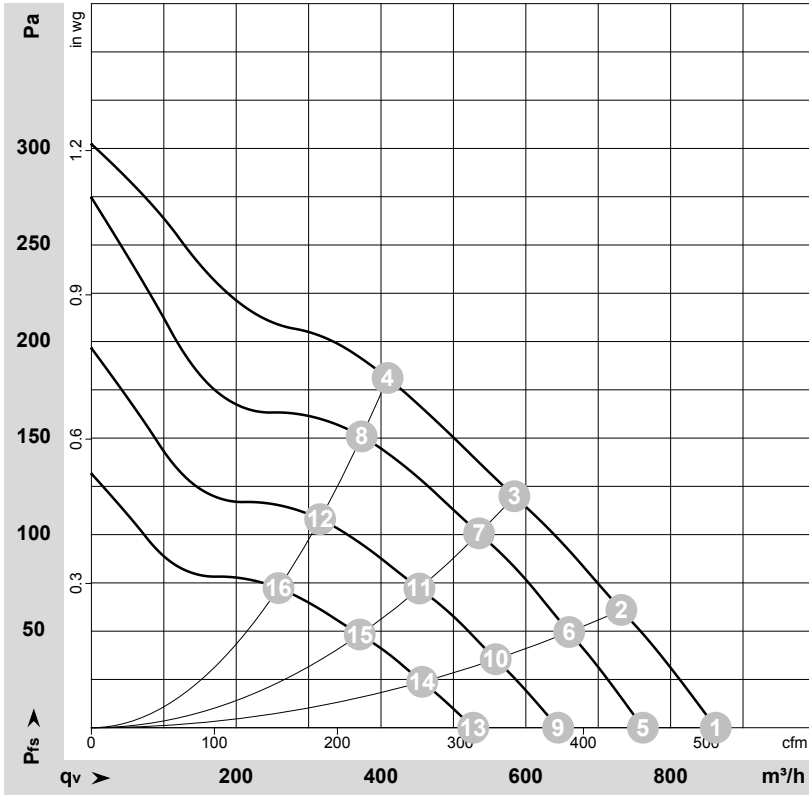

$\rho = 1.15 \text{ kg/m}^3 \pm 2 \%$

Measurement: LU-175569-1

Air performance measured as per ISO 5801 Installation category A. For detailed information on the measuring set-up, please contact ebmpapst. Suction-side noise levels: LwA measured as per ISO 13347 / LpA measured with 1m distance to fan axis. The values given are valid under the measuring conditions mentioned above and may vary according to the actual installation situation. With any deviation from the standard set-up, the specific values have to be checked and reviewed with the unit installed.

Measured values

	U	f	n	P _{ed}	I	LpA _{in}	LwA _{in}	q _v	P _{fs}	q _v	P _{fs}
	V	Hz	min ⁻¹	W	A	dB(A)	dB(A)	m ³ /h	Pa	cfm	inH ₂ O
1	115	50	2945	59	0.96	62	70	860	0	505	0.00
2	115	50	2885	62	1.00	61	69	730	60	430	0.24
3	115	50	2850	65	1.00	59	68	585	120	345	0.48
4	115	50	2845	64	1.00	59	68	410	180	240	0.72
5	115	50	2600	41	0.66	59	67	760	0	450	0.00
6	115	50	2600	46	0.74	58	66	660	49	390	0.20
7	115	50	2600	50	0.80	57	65	535	101	315	0.41
8	115	50	2600	49	0.79	57	65	375	152	220	0.61
9	115	50	2200	25	0.40	55	63	645	0	380	0.00
10	115	50	2200	28	0.45	54	62	560	35	330	0.14
11	115	50	2200	30	0.49	53	61	455	72	265	0.29
12	115	50	2200	30	0.48	53	61	315	109	185	0.44
13	115	50	1800	14	0.22	50	58	525	0	310	0.00
14	115	50	1800	15	0.24	49	57	455	24	270	0.10
15	115	50	1800	17	0.27	48	56	370	48	220	0.19
16	115	50	1800	16	0.26	48	56	260	73	150	0.29

U = Supply voltage · f = Frequency · n = Speed (rpm) · P_{ed} = Power input · I = Current draw · LpA_{in} = Sound pressure level inlet side · LwA_{in} = Sound power level inlet side · q_v = Air flow
P_{fs} = Pressure increase

