

K3G133-VG01-11

EC centrifugal module

backward curved, single inlet

with support structure

K3G133-VG01-11 ebmpapst Datasheet

sales@fansco.com

www.fansco.com

Limited partnership · Headquarters Muldingen
County court Stuttgart · HRA 590344

General partner Elektrobau Muldingen GmbH · Headquarters Muldingen
County court Stuttgart · HRB 590142

Nominal data

Type	K3G133-VG01-11	
Motor	M3G045-AI	
Phase		1~
Nominal voltage	VAC	230
Nominal voltage range	VAC	200 .. 240
Frequency	Hz	50/60
Type of data definition		ml
Speed (rpm)	min ⁻¹	3770
Power input	W	28
Current draw	A	0.29
Min. ambient temperature	°C	-25
Max. ambient temperature	°C	60

ml = Max. load · me = Max. efficiency · fa = Running at free air · cs = Customer specs · cu = Customer unit
Subject to alterations



Technical features

Mass	5.8 kg
Size	133 mm
Surface of rotor	Thick layer passivated
Material of impeller	PA plastic
Housing material	PA plastic
Material of support structure	Sheet steel, galvanised
Material of guard grille	PA plastic
Number of blades	7
Direction of rotation	Clockwise, seen on rotor
Type of protection	IP 54
Insulation class	"B"
Humidity (F)/environmental protection class (H)	H1
Max. permissible ambient motor temp. (transp./ storage)	+ 80 °C
Min. permissible ambient motor temp. (transp./storage)	- 40 °C
Mounting position	Any
Condensate discharge holes	None, open rotor
Operation mode	S1
Motor bearing	Ball bearing
Technical features	<ul style="list-style-type: none"> - Tach output - Output limit - Motor current limit - Soft start - Control input 0-10 VDC / PWM - Control interface with SELV potential safely disconnected from the mains - Overvoltage detection - Over-temperature protected electronics / motor - Line undervoltage detection
EMC interference immunity	Acc. to EN 61000-6-2 (industrial environment)
EMC harmonics	Acc. to EN 61000-3-2/3
EMC interference emission	Acc. to EN 61000-6-3 (household environment)
Touch current acc. IEC 60990 (measuring network Fig. 4, TN system)	<= 3.5 mA
Electrical leads	With plug
Motor protection	Locked-rotor protection
Cable exit	Lateral
Protection class	I (if protective earth is connected by customer at the connection point of the housing)
Product conforming to standard	EN 60335-1; CE
Approval	C22.2 Nr.77 + CAN/CSA-E60730-1; UL 1004-7 + 60730

EC centrifugal module

backward curved, single inlet
with support structure

Product drawing

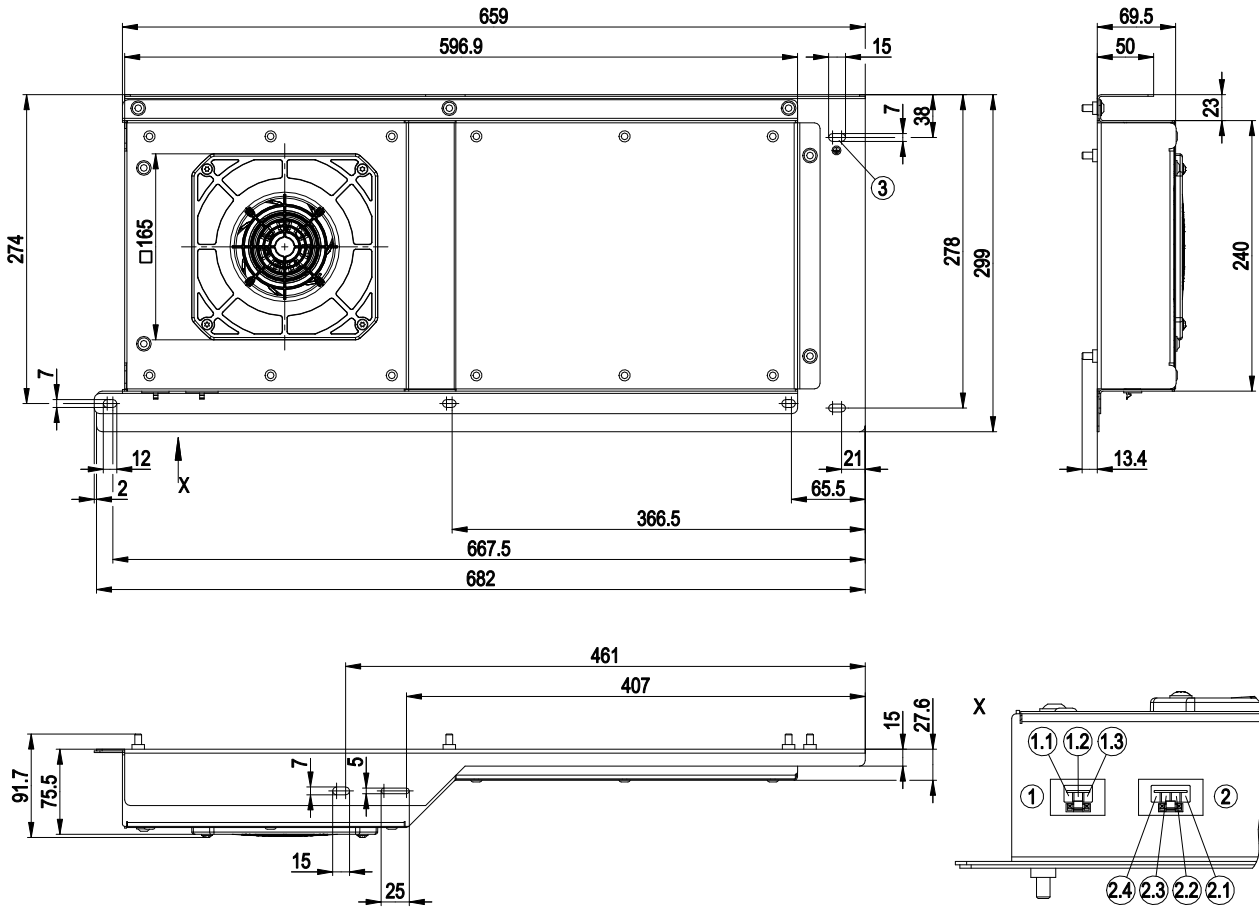

1	Connection line PVC AWG20 with connector housing 3-pole WAGO 890-733 and strain relief
1.1	N (blue)
1.2	PE (green/yellow)
1.3	L (black)
2	Connection line PVC AWG22 with connector housing 4-pole WAGO 890-754 and strain relief
2.1	yellow
2.2	white
2.3	blue
2.4	not used
3	Earth conductor connection point



EC centrifugal module

backward curved, single inlet
with support structure

Connection screen

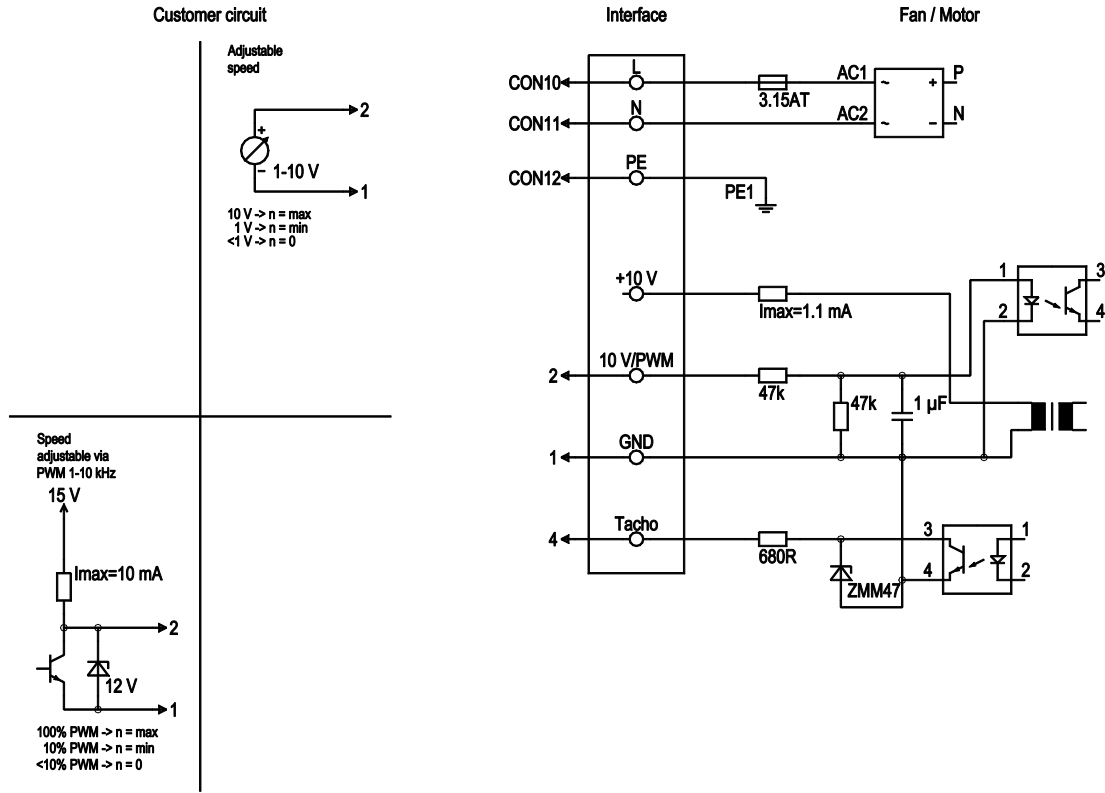

No.	Conn.	Designation	Colour	Function / assignment
	CON10	L	black	Power supply 230 VAC, 50-60 Hz, see type plate for voltage range
	CON11	N	blue	Neutral conductor
	CON12	PE	green/yellow	Protective earth
	1	GND	blue	GND connection for control interface
	2	0-10V PWM	yellow	Control input 0-10 V or PWM, electrically isolated
	4	Tacho	white	Tach output: open collector, 1 pulse per revolution, electrically isolated, I _{sink_max} =10 mA



EC centrifugal module

backward curved, single inlet
with support structure

Charts: Air flow 50 Hz

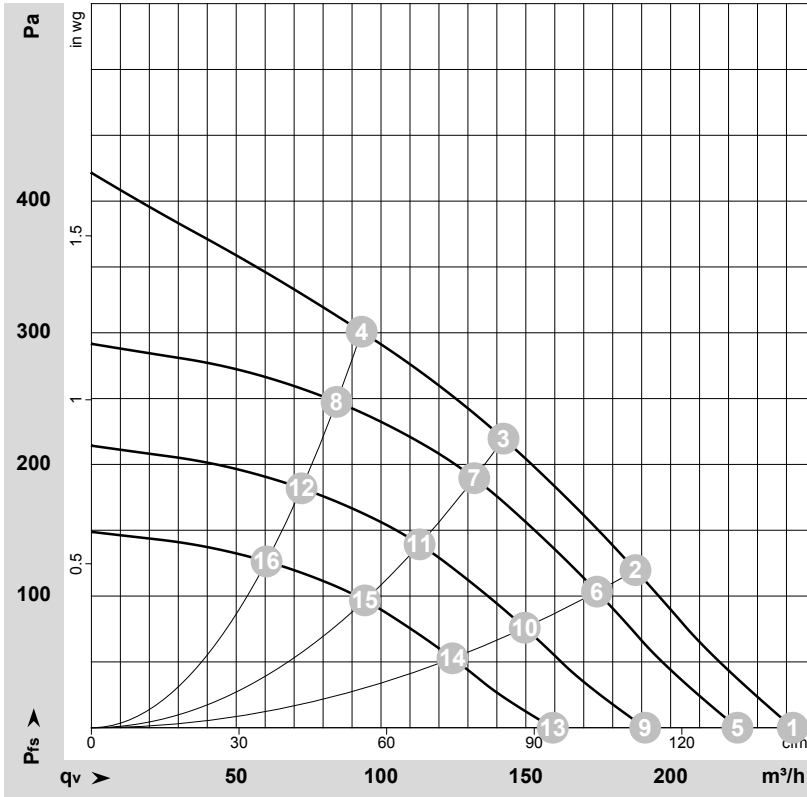

$\rho = 1.15 \text{ kg/m}^3 \pm 2 \%$

Measurement: LU-172126-1

Air performance measured as per ISO 5801 Installation category A. For detailed information on the measuring set-up, please contact ebmpapst. Suction-side noise levels: LwA measured as per ISO 13347 / LpA measured with 1m distance to fan axis. The values given are valid under the measuring conditions mentioned above and may vary according to the actual installation situation. With any deviation from the standard set-up, the specific values have to be checked and reviewed with the unit installed.

Measured values

	U	f	n	P _{ed}	I	q _v	P _{fs}	q _v	P _{fs}
	V	Hz	min ⁻¹	W	A	m ³ /h	Pa	cfm	inH2O
1	230	50	3800	28	0.29	240	0	140	0.00
2	230	50	3770	28	0.29	190	120	110	0.48
3	230	50	3770	28	0.29	140	220	85	0.88
4	230	50	3855	26	0.27	95	300	55	1.20
5	230	50	3500	22	0.22	225	0	130	0.00
6	230	50	3500	23	0.23	175	104	105	0.42
7	230	50	3500	23	0.24	130	191	80	0.77
8	230	50	3500	20	0.20	85	248	50	1.00
9	230	50	3000	14	0.14	190	0	110	0.00
10	230	50	3000	14	0.15	150	76	90	0.31
11	230	50	3000	15	0.15	115	141	65	0.57
12	230	50	3000	12	0.13	75	182	45	0.73
13	230	50	2500	8.0	0.08	160	0	95	0.00
14	230	50	2500	8.0	0.08	125	53	75	0.21
15	230	50	2500	8.0	0.09	95	98	55	0.39
16	230	50	2500	7.0	0.07	60	126	35	0.51

U = Supply voltage · f = Frequency · n = Speed (rpm) · P_{ed} = Power input · I = Current draw · q_v = Air flow · P_{fs} = Pressure increase

