

K3G133-RA01-10

# EC centrifugal module - RadiCal

backward curved, single inlet

with housing



K3G133-RA01-10 ebmpapst Datasheet

[sales@fansco.com](mailto:sales@fansco.com)

[www.fansco.com](http://www.fansco.com)

Limited partnership · Headquarters Muldingen  
County court Stuttgart · HRA 590344

General partner Elektrobau Muldingen GmbH · Headquarters Muldingen  
County court Stuttgart · HRB 590142

## Nominal data

Type	K3G133-RA01-10	
Motor	M3G045-AI	
Phase		1~
Nominal voltage	VAC	230
Nominal voltage range	VAC	200 .. 240
Frequency	Hz	50/60
Type of data definition		ml
Speed (rpm)	min <sup>-1</sup>	3770
Power input	W	27
Current draw	A	0.27
Min. ambient temperature	°C	-25
Max. ambient temperature	°C	60

ml = Max. load · me = Max. efficiency · fa = Running at free air · cs = Customer specs · cu = Customer unit  
Subject to alterations



backward curved, single inlet  
with housing

### Technical features

Mass	0.9 kg
Size	133 mm
Surface of rotor	Thick layer passivated
Material of electronics housing	Die-cast aluminium
Material of impeller	PA plastic
Housing material	PA plastic
Number of blades	7
Direction of rotation	Clockwise, seen on rotor
Type of protection	IP 54
Insulation class	"B"
Humidity (F)/environmental protection class (H)	H1
Max. permissible ambient motor temp. (transp./ storage)	+ 80 °C
Min. permissible ambient motor temp. (transp./storage)	- 40 °C
Mounting position	Any
Condensate discharge holes	None, open rotor
Operation mode	S1
Motor bearing	Ball bearing
Technical features	<ul style="list-style-type: none"> <li>- Tach output</li> <li>- Output limit</li> <li>- Motor current limit</li> <li>- Soft start</li> <li>- Control input 0-10 VDC / PWM</li> <li>- Control interface with SELV potential safely disconnected from the mains</li> <li>- Overvoltage detection</li> <li>- Over-temperature protected electronics / motor</li> <li>- Line undervoltage detection</li> </ul>
EMC interference immunity	Acc. to EN 61000-6-2 (industrial environment)
EMC harmonics	Acc. to EN 61000-3-2/3
EMC interference emission	Acc. to EN 61000-6-3 (household environment)
Touch current acc. IEC 60990 (measuring network Fig. 4, TN system)	<= 3.5 mA
Motor protection	Locked-rotor protection
Cable exit	Lateral
Protection class	I (if protective earth is connected by customer)
Product conforming to standard	EN 60335-1; CE
Approval	C22.2 Nr.77 + CAN/CSA-E60730-1; UL 1004-7 + 60730



# EC centrifugal module - RadiCal

backward curved, single inlet  
with housing

## Product drawing

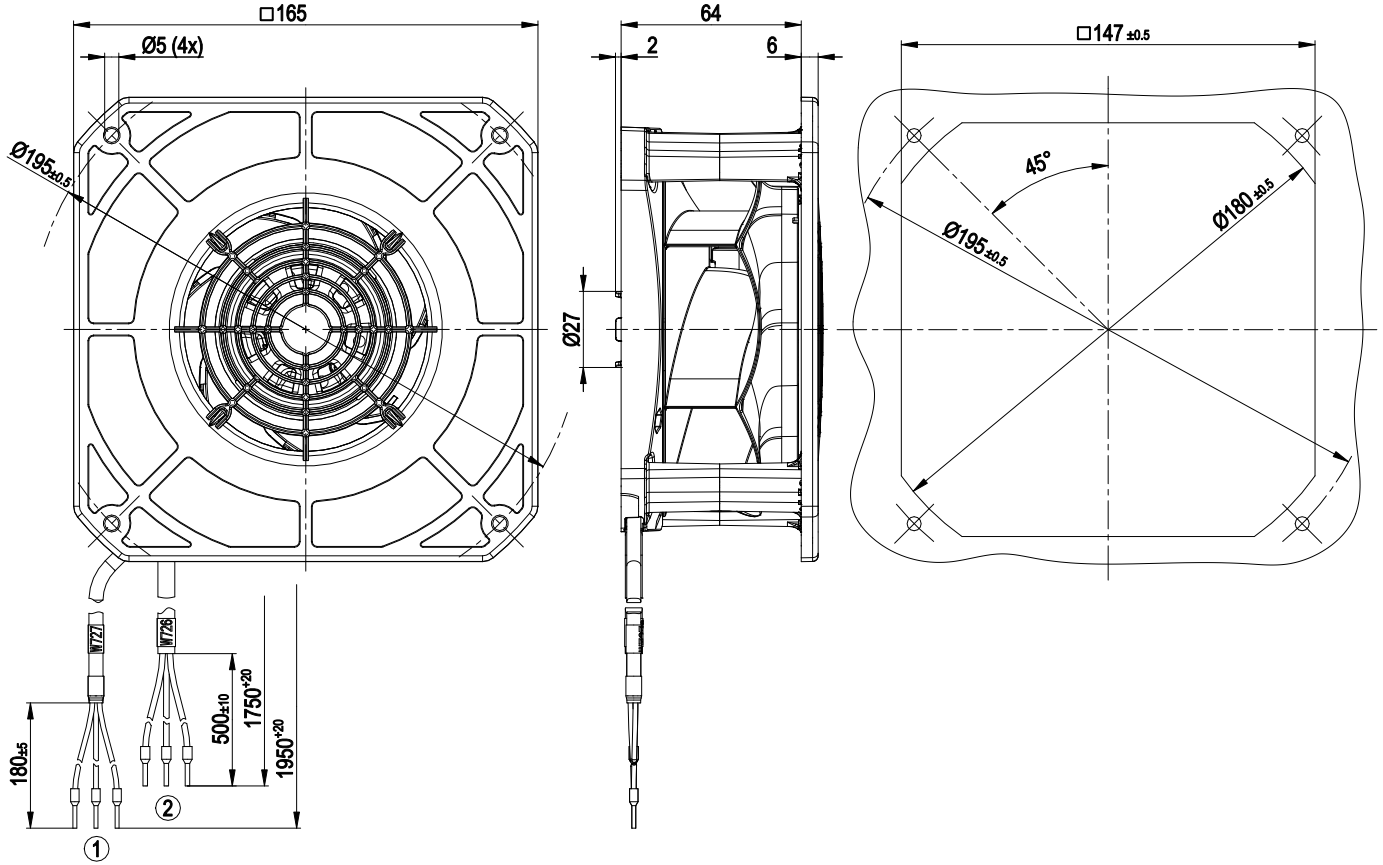

- |   |  |
|---|--|
| 1 | Connection line PVC AWG22, 3x crimped core-end sleeves |
| 2 | Connection line PVC AWG20, 3x crimped core-end sleeves |



# EC centrifugal module - RadiCal

backward curved, single inlet  
with housing

## Connection screen

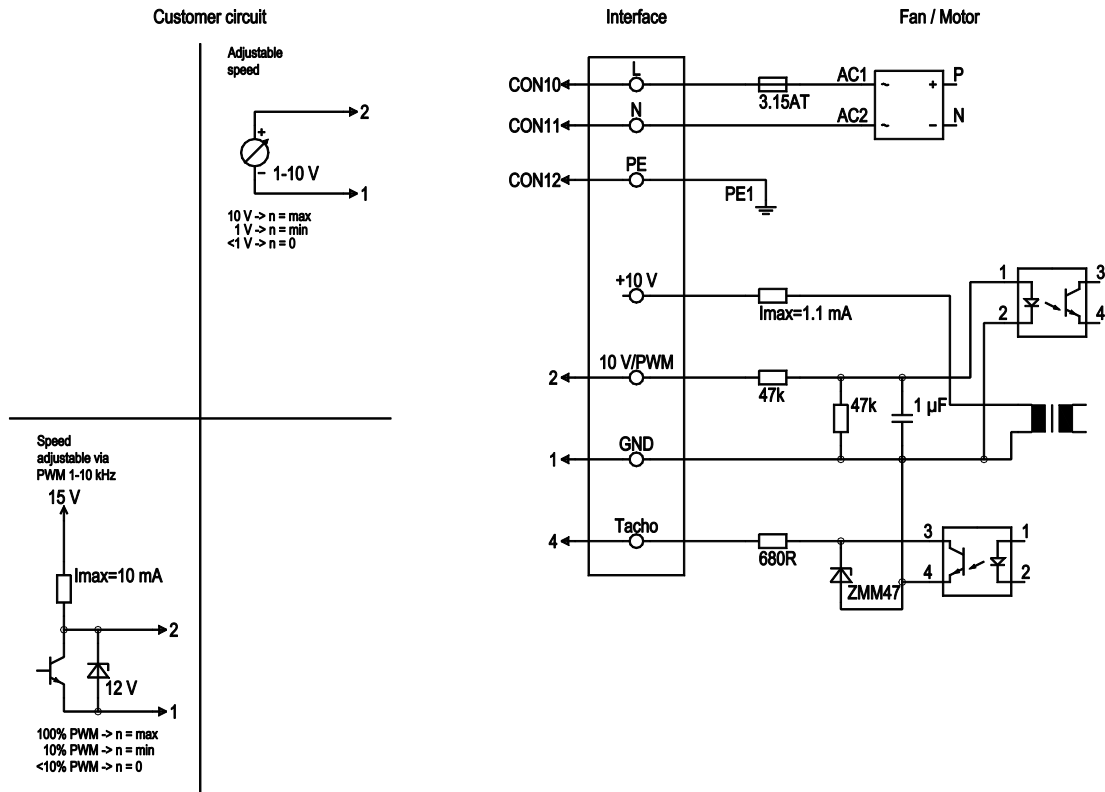

No.	Conn.	Designation	Colour	Function / assignment
	CON10	L	black	Power supply 230 VAC, 50-60 Hz, see type plate for voltage range
	CON11	N	blue	Neutral conductor
	CON12	PE	green/yellow	Protective earth
	1	GND	blue	GND connection for control interface
	2	0-10V PWM	yellow	Control input 0-10 V or PWM, electrically isolated
	4	Tacho	white	Tach output: open collector, 1 pulse per revolution, electrically isolated, I <sub>sink_max</sub> =10 mA



## Charts: Air flow 50 Hz

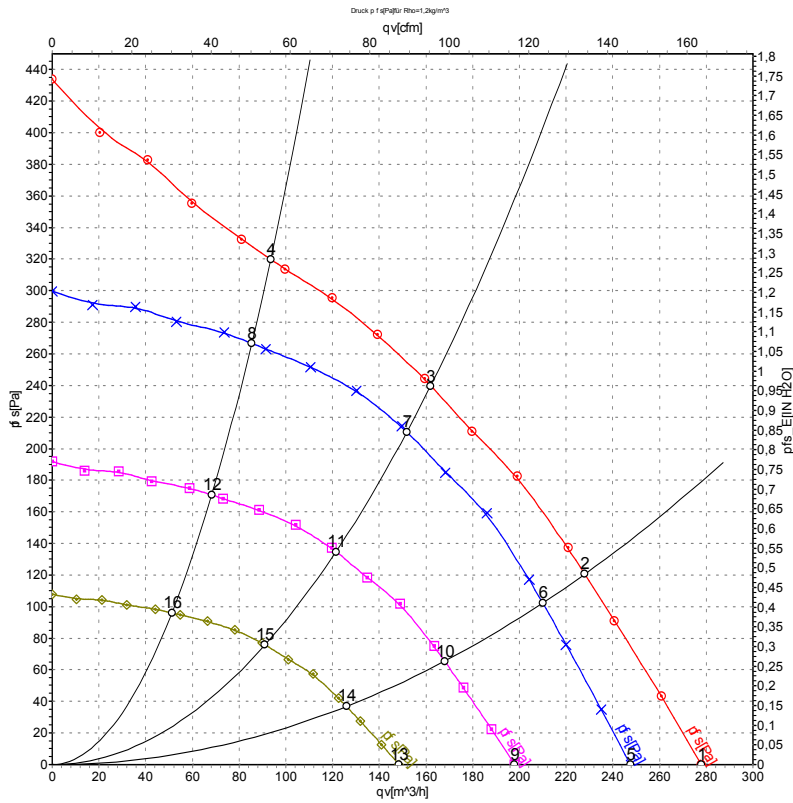

Measurement: LU-131806-1

Air performance measured as per ISO 5801 Installation category A. For detailed information on the measuring set-up, please contact ebmpapst. Suction-side noise levels: LwA measured as per ISO 13347 / LpA measured with 1m distance to fan axis. The values given are valid under the measuring conditions mentioned above and may vary according to the actual installation situation. With any deviation from the standard set-up, the specific values have to be checked and reviewed with the unit installed.

## Measured values

	U	f	n	P <sub>ed</sub>	I	LpA <sub>in</sub>	LwA <sub>in</sub>	q <sub>v</sub>	P <sub>fs</sub>	q <sub>v</sub>	P <sub>fs</sub>
	V	Hz	min <sup>-1</sup>	W	A	dB(A)	dB(A)	m <sup>3</sup> /h	Pa	cfm	inH2O
1	230	50	3930	24	0.23	58	66	280	0	165	0.00
2	230	50	3800	26	0.26	54	63	230	120	135	0.48
3	230	50	3770	27	0.27	52	61	160	240	95	0.96
4	230	50	3835	26	0.25	56	65	95	320	55	1.28
5	230	50	3500	17	0.16	55	64	250	0	145	0.00
6	230	50	3500	20	0.20	53	61	210	102	125	0.41
7	230	50	3500	22	0.22	51	59	150	211	90	0.85
8	230	50	3500	19	0.19	54	63	85	267	50	1.07
9	230	50	2800	8.5	0.08	50	59	200	0	115	0.00
10	230	50	2800	10	0.10	48	57	170	66	100	0.26
11	230	50	2800	11	0.11	46	55	120	135	70	0.54
12	230	50	2800	9.9	0.10	49	59	70	171	40	0.69
13	230	50	2100	3.6	0.04	44	53	150	0	85	0.00
14	230	50	2100	4.4	0.04	42	50	125	37	75	0.15
15	230	50	2100	4.8	0.05	39	48	90	76	55	0.31
16	230	50	2100	4.2	0.04	43	52	50	96	30	0.39

U = Supply voltage · f = Frequency · n = Speed (rpm) · P<sub>ed</sub> = Power input · I = Current draw · LpA<sub>in</sub> = Sound pressure level inlet side · LwA<sub>in</sub> = Sound power level inlet side · q<sub>v</sub> = Air flow  
P<sub>fs</sub> = Pressure increase

