

K3G097-AS81-81

# EC dual centrifugal fan

forward-curved, dual-intake  
with housing, for rail applications



K3G097-AS81-81 ebmpapst Datasheet

[sales@fansco.com](mailto:sales@fansco.com)

[www.fansco.com](http://www.fansco.com)

## Nominal data

Type	K3G097-AS81-81	
Motor	M3G084-BF	
Nominal voltage	VDC	26
Nominal voltage range	VDC	16 .. 32
Method of obtaining data		fa
Speed (rpm)	min <sup>-1</sup>	3900
Power consumption	W	435
Min. back pressure	Pa	0
Min. back pressure	in. wg	0
Min. ambient temperature	°C	-40
Max. ambient temperature	°C	85

ml = Max. load · me = Max. efficiency · fa = Free air · cs = Customer specification · ce = Customer equipment  
Subject to change



# EC dual centrifugal fan

forward-curved, dual-intake

with housing, for rail applications

## Technical description

<b>Weight</b>	2.2 kg
<b>Size</b>	97 mm
<b>Motor size</b>	84
<b>Impeller material</b>	PA plastic UL94 V0
<b>Housing material</b>	PA plastic UL94 V0
<b>Number of blades</b>	34
<b>Balancing grade according to DIN ISO 21940-11</b>	G 2.5
<b>Direction of rotation</b>	Clockwise, viewed toward rotor
<b>Degree of protection</b>	Motor IP24 KM, electronics IP6K9K (mating connector installed)
<b>Insulation class</b>	"B"
<b>Moisture (F) / Environmental (H) protection class</b>	H3
<b>Max. permitted ambient temp. for motor (transport/storage)</b>	+85 °C
<b>Min. permitted ambient temp. for motor (transport/storage)</b>	-40 °C
<b>Installation position</b>	Any
<b>Condensation drainage holes</b>	None, open rotor
<b>Mode</b>	S1
<b>Motor bearing</b>	Ball bearing; (sealed)
<b>Technical features</b>	<ul style="list-style-type: none"> <li>- Lowering input</li> <li>- Error output (high-side switch)</li> <li>- INVLIN (inverse linear control input)</li> <li>- Power limiter</li> <li>- Load dump (58 V)</li> <li>- Motor current limitation</li> <li>- Soft start</li> <li>- Control input 0-10 VDC / PWM</li> <li>- Temperature derating (Fault message via diagnostic output in derating operation)</li> <li>- Overvoltage detection</li> <li>- Thermal overload protection for electronics</li> <li>- Line undervoltage detection</li> <li>- Reverse polarity protection</li> </ul>
<b>EMC regulations</b>	According to EN 50121-3-2
<b>Electrical hookup</b>	Standby current less than 500 µA
<b>With cable</b>	Lateral
<b>Protection class assignment</b>	<p>III; Requires supply with safety extra-low voltage SELV.</p> <p>This component for installation may have several local protection classes. This information relates to this component's basic design.</p> <p>The final protection class is based on the component's intended installation and connection. If there is a PE connection point on the housing, it must not be visible after installation.</p>
<b>Conformity with standards</b>	EN 15085-1, CPC3; EN 45545-2, HL3; EN 50155; EN 61373, Cat. 1B
<b>Approval</b>	EAC



# EC dual centrifugal fan

forward-curved, dual-intake  
with housing, for rail applications

## Product drawing

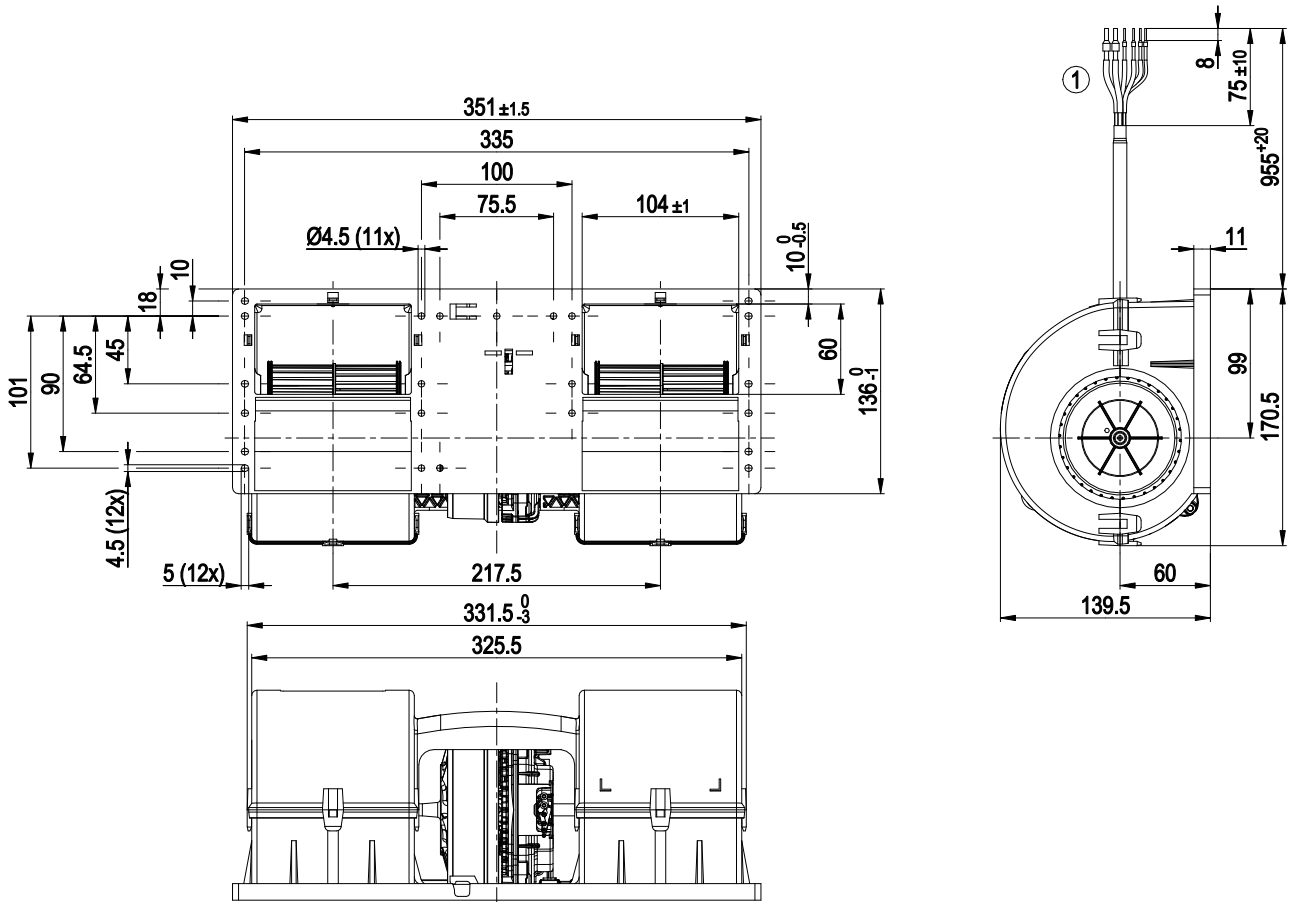

- |   |  |
|---|--|
| 1 | Cable, halogen-free, railway application EN 45545, 2x 2.5 mm <sup>2</sup> , 4x 1.0 mm <sup>2</sup> |
|   | 6x wire-end ferrule  |



# EC dual centrifugal fan

forward-curved, dual-intake  
with housing, for rail applications

## Connection diagram

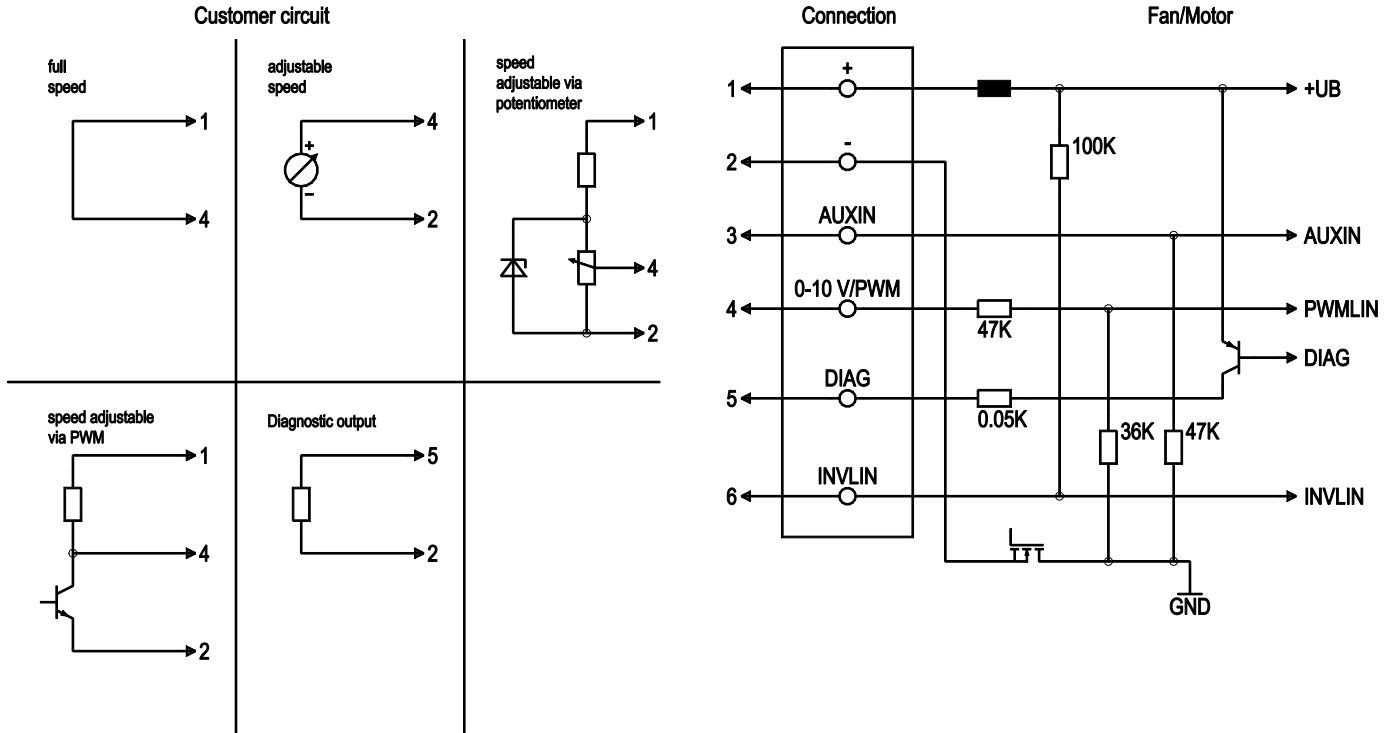

No.	Conn.	Designation	Color	Function/assignment
	1	+	black	Power supply, see nameplate for voltage range
	2	-	brown	Power supply, see nameplate for voltage range
	3	AUXIN	blue	Digital input: when active (> 4 V), value of PWM signal is halved
	4	0-10 V / PWM	yellow	Control input: $R_i > 47 \text{ k}\Omega$ 0-10 V (typ. < 1 V -> n=0; 1.5 V -> n=min; > 10 V -> n=max) PWM (amplitude 10 V; 1-50 kHz; typ. < 5 % -> n=0; 15% -> n=min; > 100% -> n=max)
	5	DIAG	white	Diagnostic output: Open collector, $I_{\text{source max}} = 20 \text{ mA}$ , Fan OK -> low; fan error -> high
	6	INVLIN	orange	Control input, inverse linear



# EC dual centrifugal fan

forward-curved, dual-intake  
with housing, for rail applications

## Curves: Air performance

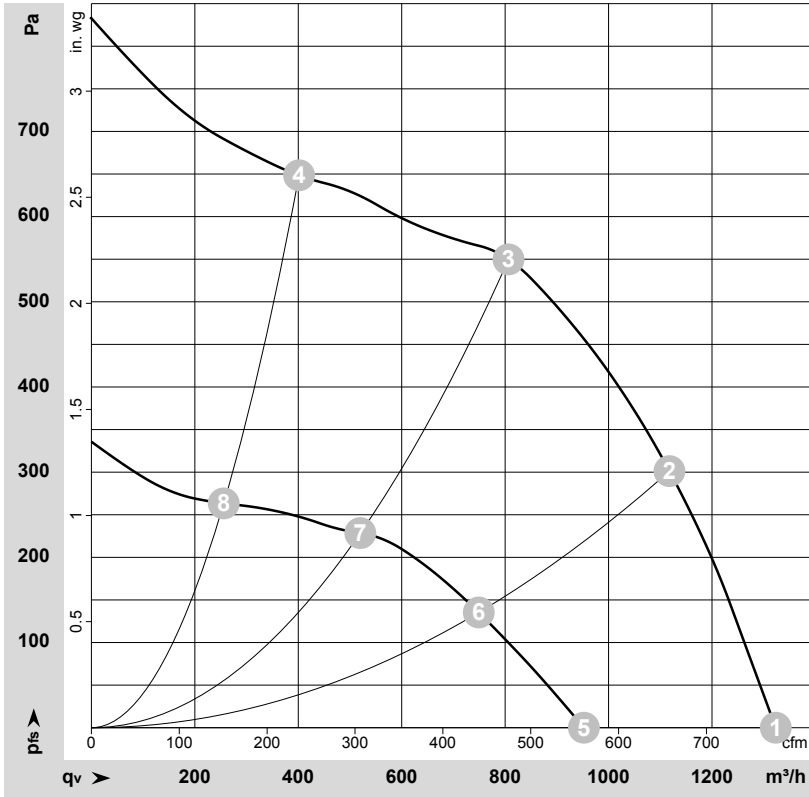

$\rho = 1.15 \text{ kg/m}^3 \pm 2 \%$

Measurement: LU-163258-1  
Measurement: LU-163419-1

Air performance measured according to ISO 5801 installation category A. For detailed information on the measurement setup, contact ebm-papst. Intake sound level: Sound power level according to ISO 13347 / sound pressure level measured at 1 m distance from fan axis. The values given are valid under the specified measuring conditions and may vary due to conditions of installation. For deviations from the standard configuration, the parameters have to be checked on the installed unit.

## Measured values

	U	n	P <sub>ed</sub>	I	LpA <sub>in</sub>	LwA <sub>in</sub>	q <sub>v</sub>	P <sub>fs</sub>	q <sub>v</sub>	P <sub>fs</sub>
	V	min <sup>-1</sup>	W	A	dB(A)	dB(A)	m <sup>3</sup> /h	Pa	cfm	in. wg
1	26-32	3900	435	16.60*	73	84	1325	0	780	0.00
2	26-32	4395	408	15.70*	71	82	1120	300	660	1.20
3	26-32	4675	309	11.90*	69	80	805	550	475	2.21
4	26-32	4905	193	7.40*	69	79	400	650	235	2.61
5	16	2845	165	10.34			950	0	560	0.00
6	16	2960	126	7.88			750	135	440	0.54
7	16	3060	92	5.76			520	228	305	0.92
8	16	3150	58	3.67			255	263	150	1.06

U = Voltage · n = Speed (rpm) · P<sub>ed</sub> = Power consumption · I = Current draw · \* = Current measured at nominal voltage · LpA<sub>in</sub> = Sound pressure level intake side · LwA<sub>in</sub> = Sound power level intake side  
q<sub>v</sub> = Air flow · P<sub>fs</sub> = Pressure increase

