

K3G097-AK34-43

EC dual centrifugal fan

forward curved, dual inlet
with housing, Automotive



K3G097-AK34-43 ebmpapst Datasheet

sales@fansco.com

www.fansco.com

Nominal data

Type	K3G097-AK34-43	
Motor	M3G074-CF	
Nominal voltage	VDC	26
Nominal voltage range	VDC	16 .. 32
Type of data definition		ml
Speed	min ⁻¹	3600
Power input	W	325
Current draw	A	12.5
Min. ambient temperature	°C	-40
Max. ambient temperature	°C	85

ml = Max. load · me = Max. efficiency · fa = Running at free air · cs = Customer specs · cu = Customer unit
Subject to alterations

Data according to ErP directive

		Actual	Request 2015
01 Overall efficiency η_{es}	%	44.9	33.5
02 Measurement category		A	
03 Efficiency category		Static	
04 Efficiency grade N		55.4	44
05 Variable speed drive		Yes	

Data definition with optimum efficiency.
The ErP data is determined using a motor-impeller combination in a standardised measurement configuration.

09 Power input P_e	kW	0.22
09 Air flow q_v	m ³ /h	510
09 Pressure increase p_{fs}	Pa	625
10 Speed n	min ⁻¹	4845
11 Specific ratio*		1.01

* Specific ratio = $1 + p_{fs} / 100\,000\text{ Pa}$

LU-171155



Technical features

Mass	2.3 kg
Size	97 mm
Material of impeller	PA plastic
Housing material	PP plastic
Number of blades	34
Balance quality according to DIN ISO 1940-1	G 2.5
Direction of rotation	Clockwise, seen on rotor
Type of protection	IP 24 KM
Insulation class	"B"
Humidity (F)/environmental protection class (H)	F3-2
Max. permissible ambient motor temp. (transp./ storage)	+85 °C
Min. permissible ambient motor temp. (transp./storage)	-40 °C
Mounting position	Any
Condensate discharge holes	None, open rotor
Operation mode	S1
Motor bearing	Ball bearing; (sealed)
Life expectancies	40,000 h (typical)
Technical features	<ul style="list-style-type: none"> - Lowering input - Tach output - Fault output (high-side switch max. 30 mA) - INVLIN (control input, inverse linear) - Output limit - Load dump (58 V) - Motor current limit - Soft start - Control input 0-10 VDC / PWM - Overvoltage detection - Over-temperature protected electronics - Line undervoltage detection
EMC directives	According to ECE R10 Rev. 3
Electrical leads	With plug; Standby current less than 500 µA
Motor protection	Reverse polarity and locked-rotor protection
Approval	E1; EAC
Noise level	76 dB(A), sound power level according to ISO 13347
Remark	Type approval number – 036432

EC dual centrifugal fan

forward curved, dual inlet
with housing, Automotive

Product drawing

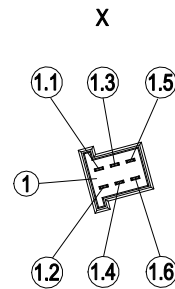
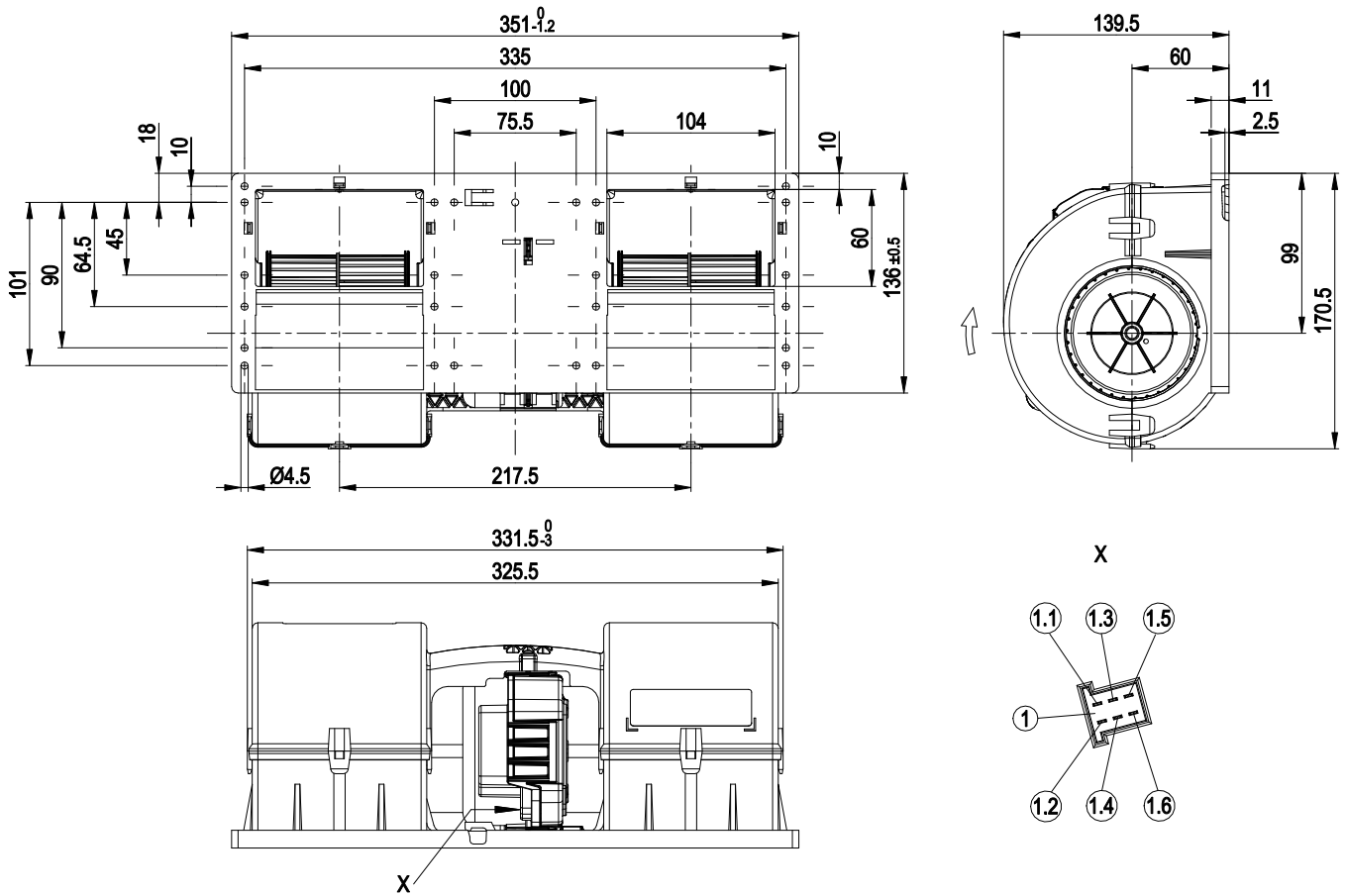

1	Strip tyco Junior Power Timer, 6-pole, coded, connection line (460 mm) with mating connector part no. 02001-4-1021 not included in scope of delivery.
1.1	+ UB
1.2	GND
1.3	PWM/LIN
1.4	INVLIN
1.5	ABSENK
1.6	Diagnostic output



EC dual centrifugal fan

forward curved, dual inlet
with housing, Automotive

Connection screen

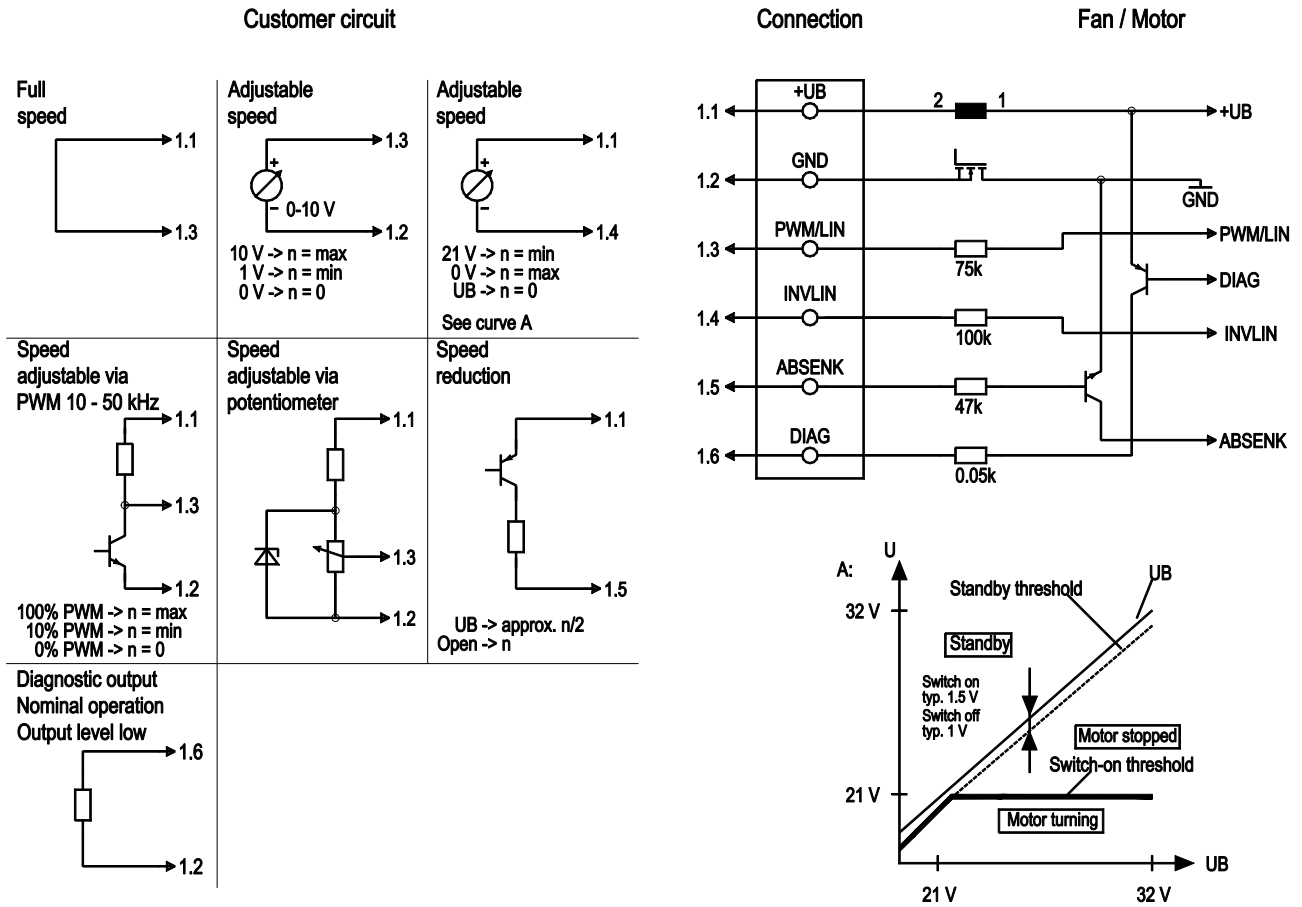

No.	Conn.	Designation	Function / assignment
	1.1	+UB	Power supply
	1.2	GND	Power supply GND, reference earth
	1.3	PWM/LIN	Analogue voltage control input 0-10 V or PWM
	1.4	INVLIN	Control input, inverse linear
	1.5	ABSENK	Lowering input
	1.6	DIAG	Diagnostic output



EC dual centrifugal fan

forward curved, dual inlet
with housing, Automotive

Charts: Air flow

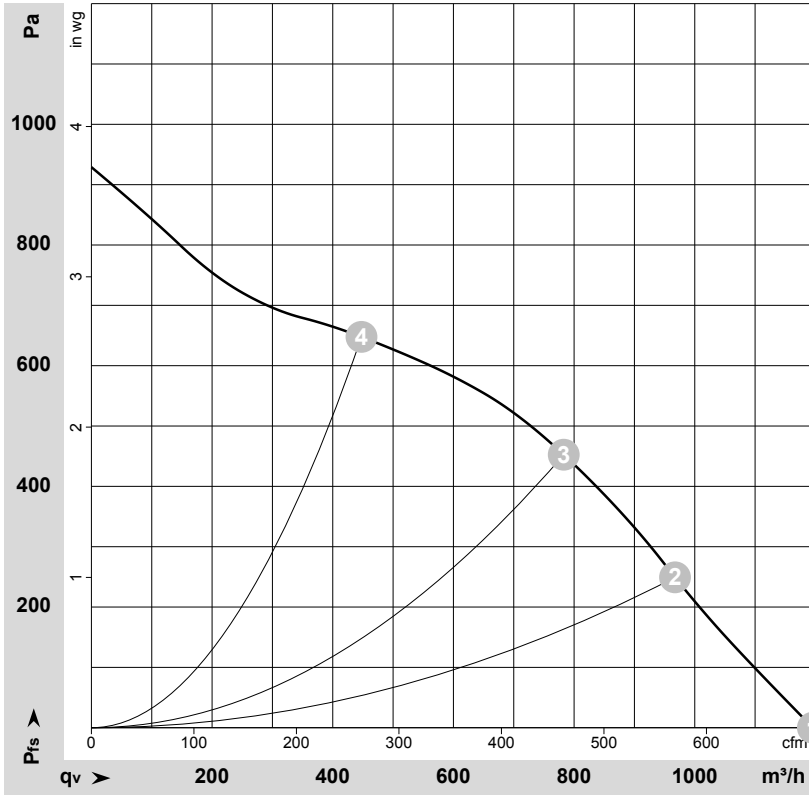

$\rho = 1.15 \text{ kg/m}^3 \pm 2 \%$

Measurement: LU-171155

Air performance measured as per ISO 5801 Installation category A. For detailed information on the measuring set-up, please contact ebmpapst. Suction-side noise levels: LwA measured as per ISO 13347 / LpA measured with 1m distance to fan axis. The values given are valid under the measuring conditions mentioned above and may vary according to the actual installation situation. With any deviation from the standard set-up, the specific values have to be checked and reviewed with the unit installed.

Measured values

	U	n	P _{ed}	I	qv	p _{fs}
	V	min ⁻¹	W	A	m ³ /h	Pa
1	26	3600	325	12.50	1195	0
2	26	3945	281	10.82	965	250
3	26	4350	266	10.21	785	450
4	26	4895	207	7.93	450	650

U = Supply voltage · n = Speed · P_{ed} = Power input · I = Current draw · qv = Air flow · p_{fs} = Pressure increase

