

K2E250-RA50-11 ebmpapst Datasheet

sales@fansco.com

www.fansco.com

Nominal data

Type	K2E250-RA50-11		
Motor	M2E068-EC		
Phase		1~	1~
Nominal voltage	VAC	230	230
Frequency	Hz	50	60
Method of obtaining data		ml	ml
Valid for approval/standard		-	-
Speed (rpm)	min ⁻¹	2500	2450
Power consumption	W	210	285
Current draw	A	0.93	1.25
Capacitor	µF	5	5
Capacitor voltage	VDB	400	400
Min. back pressure	Pa	0	0
Min. back pressure	in. wg	0	0
Min. ambient temperature	°C	-25	-25
Max. ambient temperature	°C	70	30
Starting current	A	1.5	1.4

ml = Max. load · me = Max. efficiency · fa = Free air · cs = Customer specification · ce = Customer equipment
Subject to change



Technical description

Weight	3.7 kg
Fan size	250 mm
Rotor surface	Painted black
Impeller material	PA plastic
Housing material	PA plastic
Number of blades	7
Direction of rotation	Clockwise, viewed toward rotor
Degree of protection	IP44; installation- and position-dependent as per EN 60034-5
Insulation class	"F"
Moisture (F) / Environmental (H) protection class	H1
Max. permitted ambient temp. for motor (transport/storage)	+ 80 °C
Min. permitted ambient temp. for motor (transport/storage)	- 40 °C
Installation position	Shaft horizontal or rotor on bottom; rotor on top on request
Condensation drainage holes	On rotor side
Mode	S1
Motor bearing	Ball bearing
Touch current according to IEC 60990 (measuring circuit Fig. 4, TN system)	< 0.75 mA
Electrical hookup	With plug
Motor protection	Thermal overload protector (TOP) internally connected
With cable	Variable
Protection class	I (with customer connection of protective earth)
Motor capacitor according to EN 60252-1 in safety protection class	S0
Conformity with standards	EN 60335-1
Approval	CSA C22.2 No. 77; UL 1004-3

Product drawing

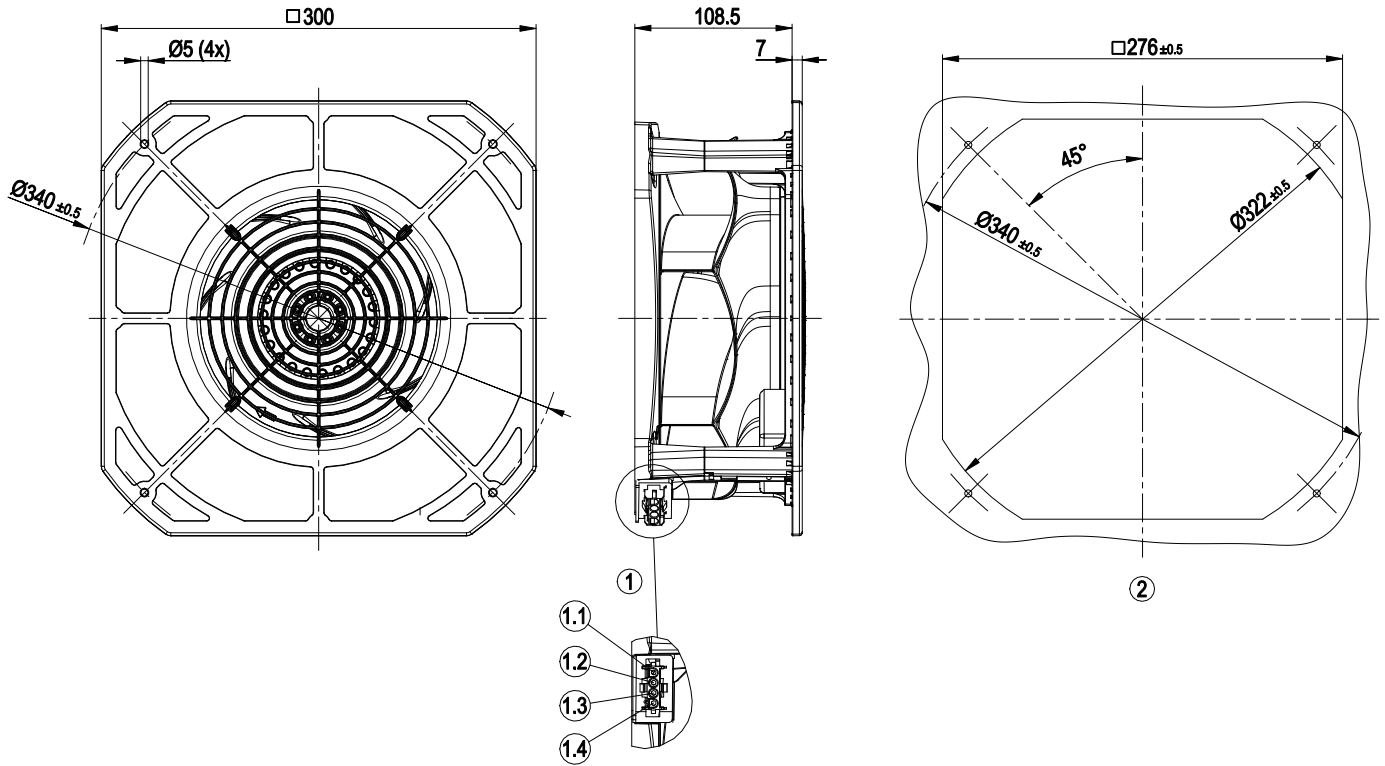

1	tyco coded plug system
	4-pole connector housing tyco 926305-7
	2x plug pin tyco 926885-1, 2x plug pin tyco 350218-1
	Mating connector (not included in scope of delivery):
	4-pole connector housing tyco 926298-6
	4x socket tyco 926 884-1
1.1	PE
1.2	L
1.3	N + capacitor
1.4	Capacitor
	(capacitor connected internally)
2	Mounting dimensions



Connection diagram

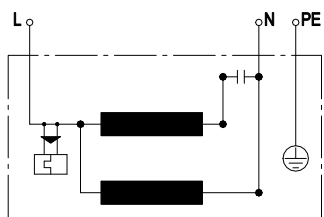

L	blue	N	black	PE	green/yellow
---	------	---	-------	----	--------------



Curves: Air performance 50 Hz

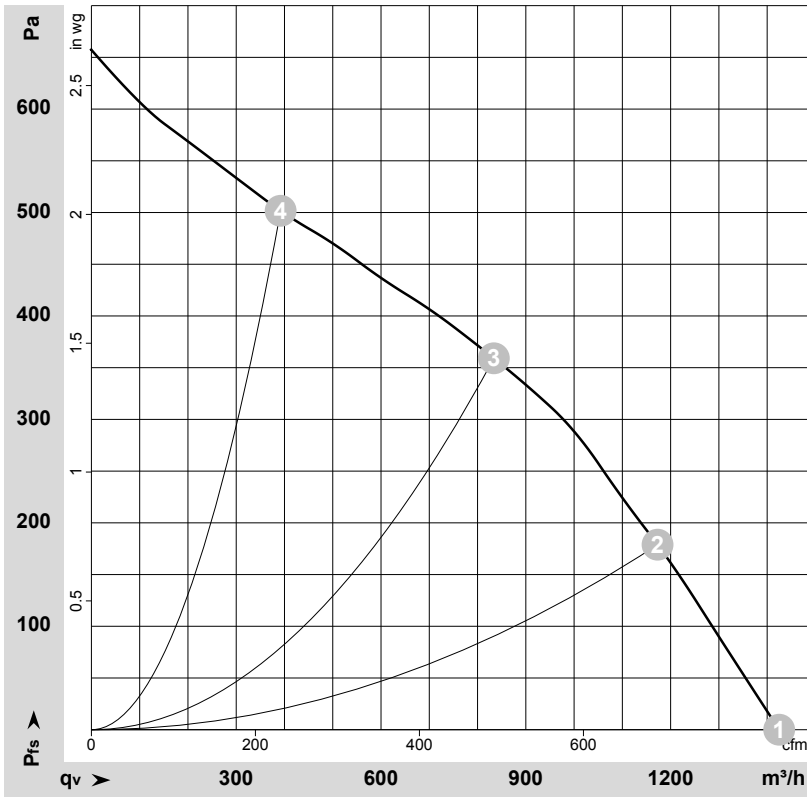

$\rho = 1.15 \text{ kg/m}^3 \pm 2 \%$

Measurement: LU-135153-1

Air performance measured according to ISO 5801 installation category A. For detailed information on the measurement setup, contact ebmpapst. Intake sound level: Sound power level according to ISO 13347 / sound pressure level measured at 1 m distance from fan axis. The values given are valid under the specified measuring conditions and may vary due to conditions of installation. For deviations from the standard configuration, the parameters have to be checked on the installed unit.

Measured values

	U	f	n	P _e	I	LpA _{in}	LwA _{in}	q _v	p _{fs}	q _v	p _{fs}
	V	Hz	min ⁻¹	W	A	dB(A)	dB(A)	m ³ /h	Pa	cfm	in. wg
1	230	50	2630	179	0.78	67	75	1425	0	840	0.00
2	230	50	2535	206	0.90	62	70	1175	180	690	0.72
3	230	50	2500	210	0.93	59	67	835	360	490	1.45
4	230	50	2615	183	0.80	65	74	390	500	230	2.01

U = Power supply · f = Frequency · n = Speed (rpm) · P_e = Power consumption · I = Current draw · LpA_{in} = Sound pressure level intake side · LwA_{in} = Sound power level intake side
q_v = Air flow · p_{fs} = Pressure increase



Curves: Air performance 60 Hz

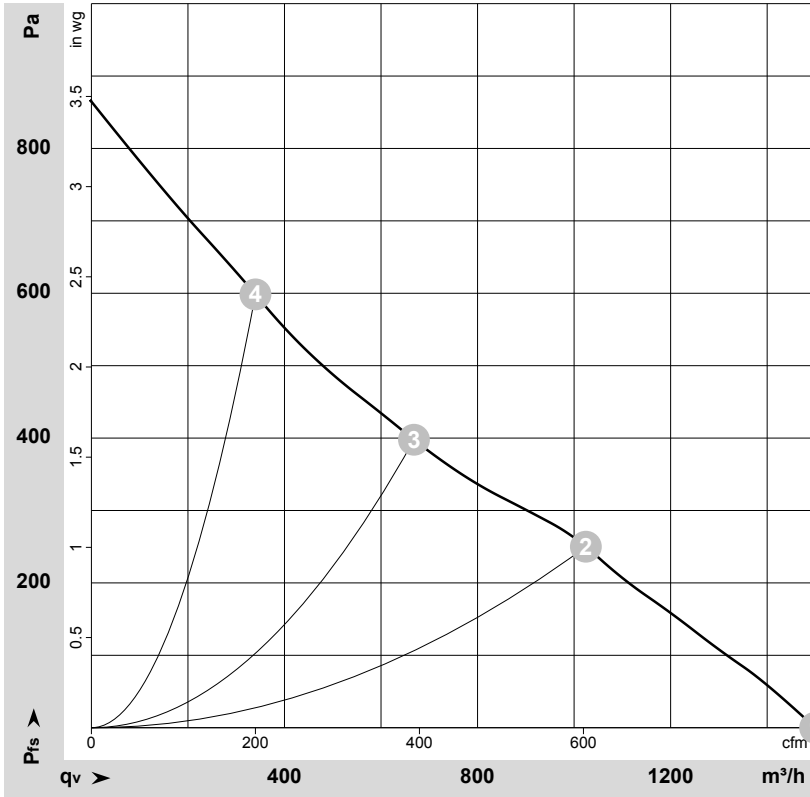

$\rho = 1.15 \text{ kg/m}^3 \pm 2 \%$

Measurement: LU-135157-1

Air performance measured according to ISO 5801 installation category A. For detailed information on the measurement setup, contact ebm-papst. Intake sound level: Sound power level according to ISO 13347 / sound pressure level measured at 1 m distance from fan axis. The values given are valid under the specified measuring conditions and may vary due to conditions of installation. For deviations from the standard configuration, the parameters have to be checked on the installed unit.

Measured values

	U	f	n	P _e	I	LpA _{in}	LwA _{in}	q _v	P _{fs}	q _v	P _{fs}
	V	Hz	min ⁻¹	W	A	dB(A)	dB(A)	m ³ /h	Pa	cfm	in. wg
1	230	60	2775	246	1.07	68	77	1500	0	880	0.00
2	230	60	2450	285	1.25	61	69	1025	250	605	1.00
3	230	60	2485	270	1.18	61	69	670	400	395	1.61
4	230	60	2830	240	1.04	68	76	340	600	200	2.41

U = Power supply · f = Frequency · n = Speed (rpm) · P_e = Power consumption · I = Current draw · LpA_{in} = Sound pressure level intake side · LwA_{in} = Sound power level intake side
q_v = Air flow · P_{fs} = Pressure increase

