

K1G220-AF92-10

EC centrifugal module

backward curved, single inlet

with support bracket

K1G220-AF92-10 ebmpapst Datasheet

sales@fansco.com

www.fansco.com

Limited partnership · Headquarters Muldingen
County court Stuttgart · HRA 590344

General partner Elektrobau Muldingen GmbH · Headquarters Muldingen
County court Stuttgart · HRB 590142

Nominal data

Type	K1G220-AF92-10		
Motor	M1G055-BD		
Phase		1~	1~
Nominal voltage	VAC	230	230
Frequency	Hz	50/60	50/60
Type of data definition			ml
Speed	min ⁻¹	1200	1600
Power input	W	-	33
Current draw	A		0.25
Min. ambient temperature	°C	-30	-30
Max. ambient temperature	°C	50	50

ml = Max. load · me = Max. efficiency · fa = Running at free air · cs = Customer specs · cu = Customer unit
Subject to alterations



K1G220-AF92-10

EC centrifugal module

backward curved, single inlet
with support bracket

Technical features

Size	220 mm
Direction of rotation	Clockwise, seen on rotor
Type of protection	IP 54
Insulation class	"B"
Humidity class	F3-1
Motor bearing	Ball bearing
Speed steps	2
Touch current acc. IEC 60990 (measuring network Fig. 4, TN system)	≤ 0.25 mA
Motor protection	Thermal overload protector (TOP) wired internally
Product conforming to standard	CE
Approval	VDE; UL 2111; CSA C22.2 Nr.77



EC centrifugal module

backward curved, single inlet
with support bracket

Product drawing

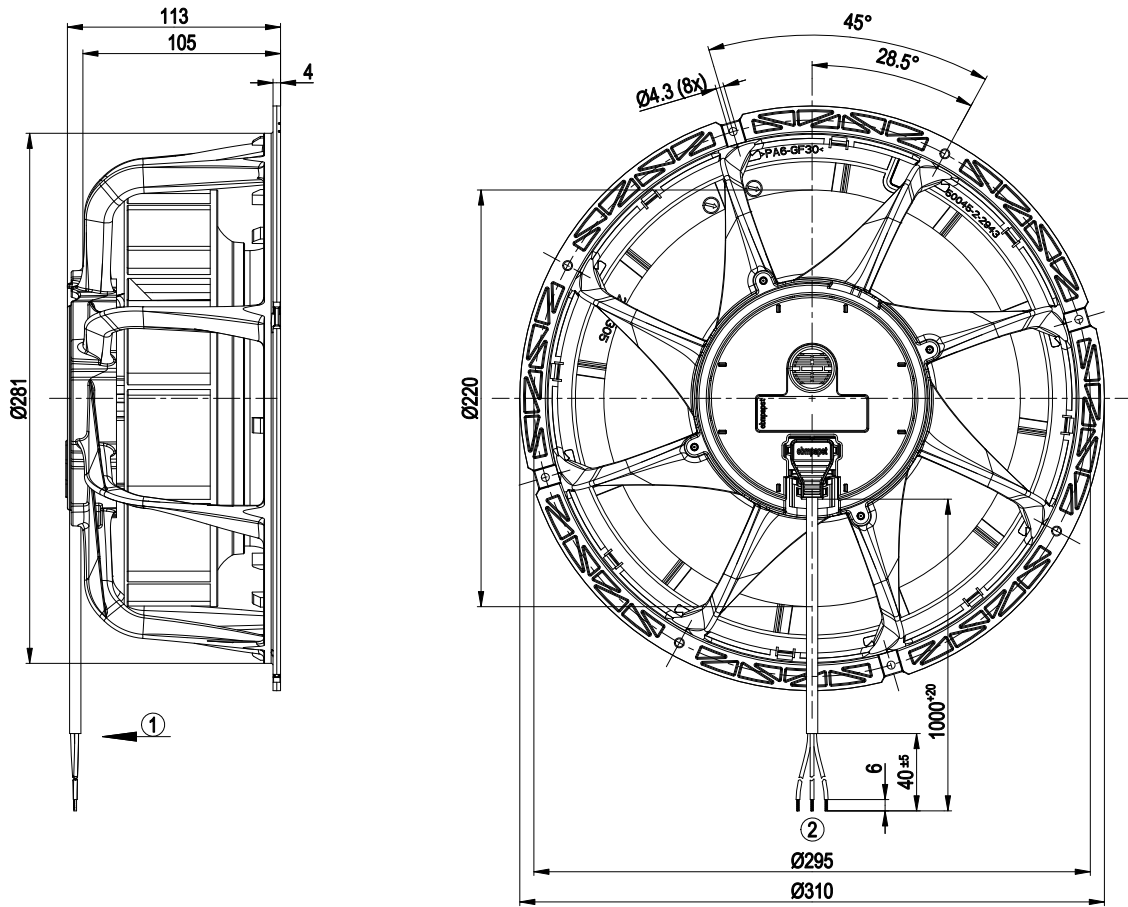

- 1 Direction of air flow "V"
- 2 Connection line PVC AWG20, 3x lead tips crimped

Connection screen

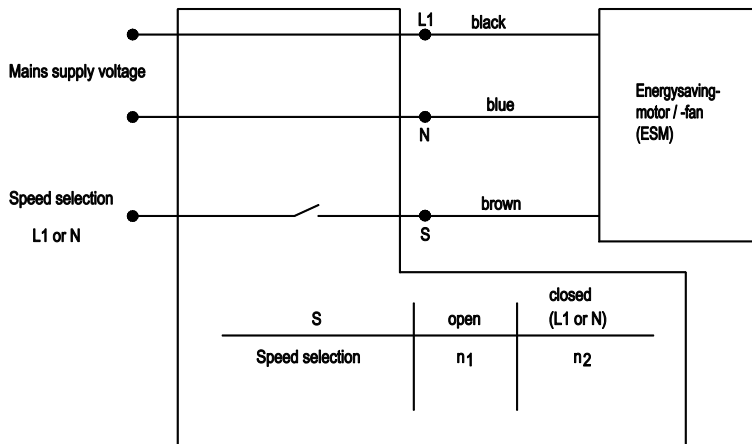

Charts: Air flow 50 Hz

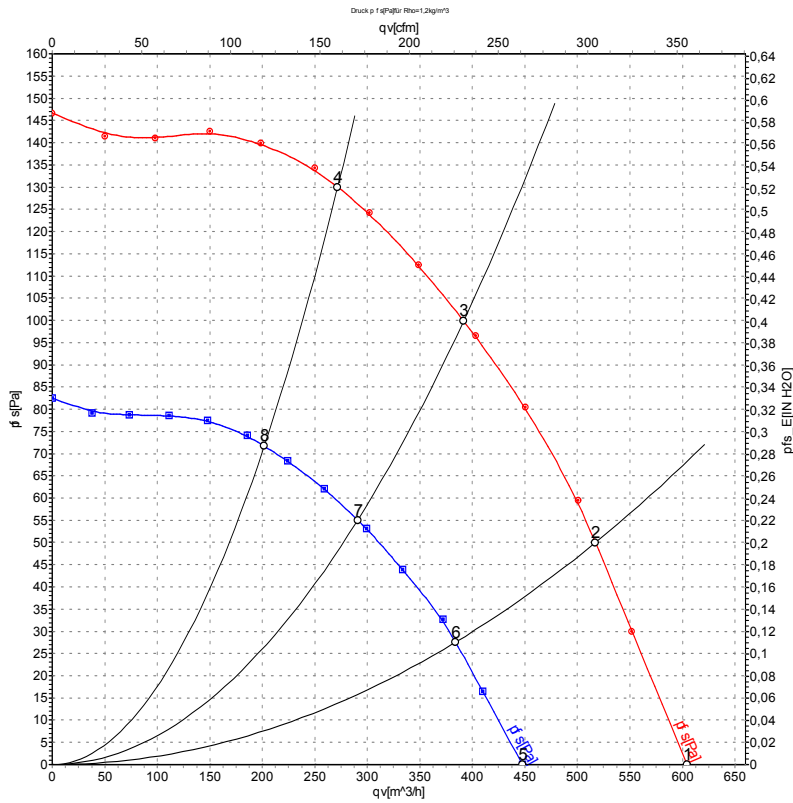

Measurement: LU-116642

Air performance measured as per ISO 5801 Installation category A. For detailed information on the measuring set-up, please contact ebm-papst. Suction-side noise levels: LwA measured as per ISO 13347 / LpA measured with 1m distance to fan axis. The values given are valid under the measuring conditions mentioned above and may vary according to the actual installation situation. With any deviation from the standard set-up, the specific values have to be checked and reviewed with the unit installed.

Measured values

	U	f	n	P _{ed}	I	LpA _{in}	LwA _{in}	qv	p _{fs}
	V	Hz	min ⁻¹	W	A	dB(A)	dB(A)	m ³ /h	Pa
1	230	50	1600	18	0.14	51	59	605	0
2	230	50	1600	25	0.20	50	57	515	50
3	230	50	1600	33	0.25	48	55	390	100
4	230	50	1600	30	0.25	49	56	270	130
5	230	50	1200	7.4	0.06	45	52	450	0
6	230	50	1200	10	0.08	43	50	385	28
7	230	50	1200	13	0.10	41	48	290	55
8	230	50	1200	13	0.10	42	50	200	72

U = Supply voltage · f = Frequency · n = Speed · P_{ed} = Power input · I = Current draw · LpA_{in} = Sound pressure level inlet side · LwA_{in} = Sound power level inlet side · qv = Air flow
p_{fs} = Pressure increase

