

# EC centrifugal fan

backward curved, single inlet

with housing (flange), Gas blower for gas-condensing heating



G3G250-MW50-01 ebmpapst Datasheet

sales@fansco.com

www.fansco.com

Limited partnership · Headquarters Mulfingen  
County court Stuttgart · HRA 590344

General partner Elektrobau Mulfingen GmbH · Headquarters Mulfingen  
County court Stuttgart · HRB 590142



## Nominal data

Type	G3G250-MW50-01	
Motor	M3G112-EA	
Phase		3~
Nominal voltage	VAC	400
Nominal voltage range	VAC	380 .. 480
Frequency	Hz	50/60
Type of data definition		ml
Speed	min <sup>-1</sup>	6100
Power input	W	2400
Current draw	A	4.0
Min. ambient temperature	°C	-25
Max. ambient temperature	°C	50
Min. temp. of flow medium	°C	-25
Max. temp. of flow medium	°C	+50

ml = Max. load · me = Max. efficiency · fa = Running at free air · cs = Customer specs · cu = Customer unit  
Subject to alterations

## Data according to ErP directive

		Actual	Request 2013	Request 2015
Installation category	A			
Efficiency category	Static			
Variable speed drive	Yes			
Specific ratio*	1.00			
Overall efficiency $\eta_{es}$	%	59.8	51.3	54.3
Efficiency grade N		66.5	58	61
Power input $P_{ed}$	kW	2.29		
Air flow $q_v$	m <sup>3</sup> /h	1165		
Pressure increase $p_{fs}$	Pa	4000		
Speed n	min <sup>-1</sup>	6495		

Data definition with optimum efficiency. LU-130108  
The ErP data is determined using a motor-impeller combination in a standardised measurement configuration.



# EC centrifugal fan

backward curved, single inlet

with housing (flange), Gas blower for gas-condensing heating

## Technical features

Mass	22.3 kg
Size	250 mm
Surface of rotor	Coated in black
Material of electronics housing	Die-cast aluminium
Material of impeller	Aluminium sheet
Housing material	Die-cast aluminium
Material of distancing profiles	Aluminium
Direction of rotation	Clockwise, seen on rotor
Type of protection	IP 20
Insulation class	"B"
Humidity class	F0
Max. permissible ambient motor temp. (transp./ storage)	+80 °C
Min. permissible ambient motor temp. (transp./storage)	-40 °C
Mounting position	Any
Cooling bore / aperture	Rotor-side
Operation mode	S1
Motor bearing	Ball bearing
Technical features	<ul style="list-style-type: none"> <li>- Output 10 VDC, max. 10 mA</li> <li>- Output 20 VDC, max. 50 mA</li> <li>- Tach output</li> <li>- Alarm relay</li> <li>- Motor current limit</li> <li>- PFC, passive</li> <li>- Soft start</li> <li>- Control input 0-10 VDC / PWM</li> <li>- Over-temperature protected electronics / motor</li> <li>- Line undervoltage / phase failure detection</li> </ul>
Touch current acc. IEC 60990 (measuring network Fig. 4, TN system)	<= 3.5 mA
Electrical leads	Via terminal box
Motor protection	Thermal overload protector (TOP) wired internally
Protection class	I (if protective earth is connected by customer)
Approval	EAC; UL 1004-7 + 60730



# EC centrifugal fan

backward curved, single inlet

with housing (flange), Gas blower for gas-condensing heating

## Product drawing

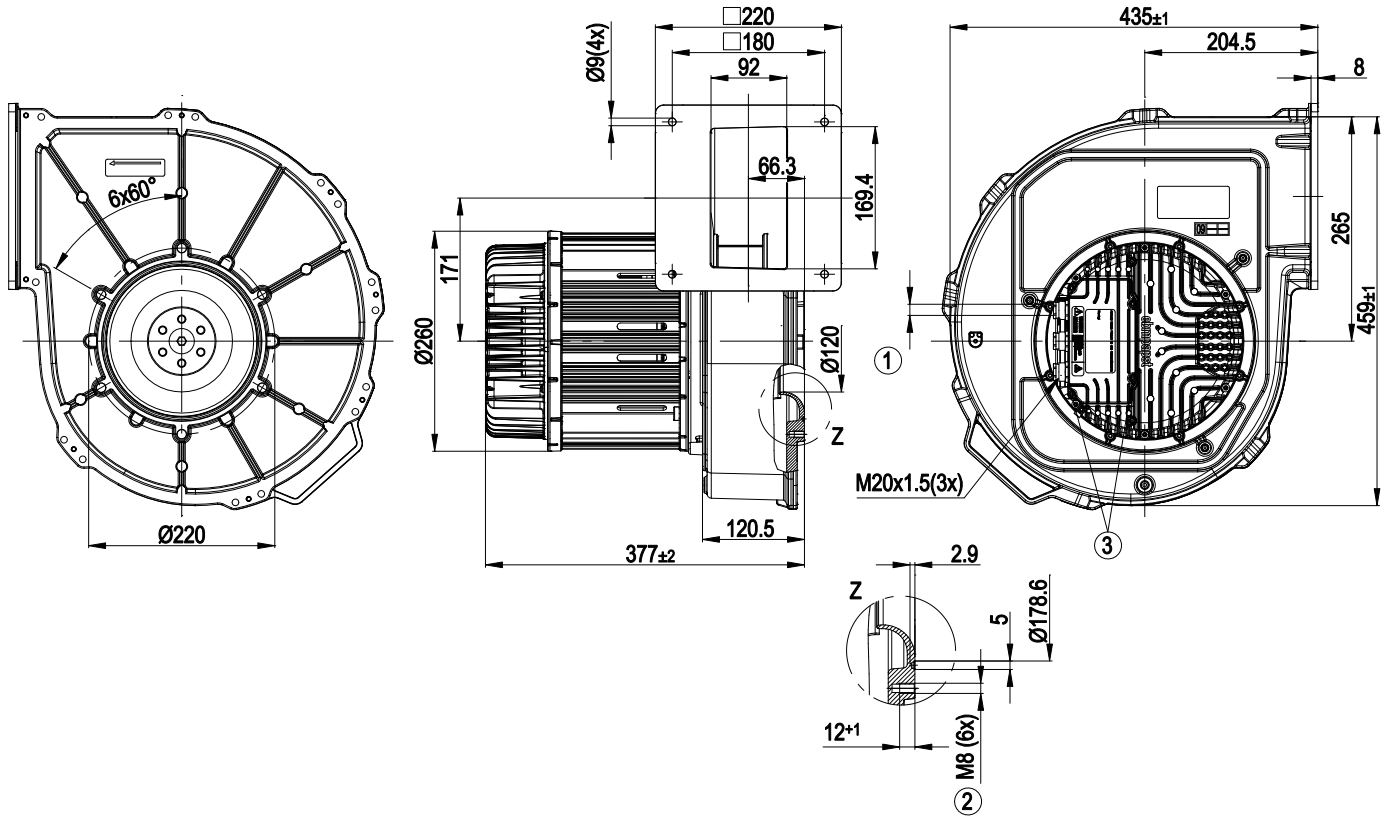

1	Cable diameter min. 4 mm, max. 10 mm, tightening torque $4 \pm 0.6$ Nm
2	Depth of screw 10-12 mm, tightening torque $20 \pm 3$ Nm
3	Tightening torque $3.5 \pm 0.5$ Nm

# EC centrifugal fan

backward curved, single inlet

with housing (flange), Gas blower for gas-condensing heating

## Connection screen

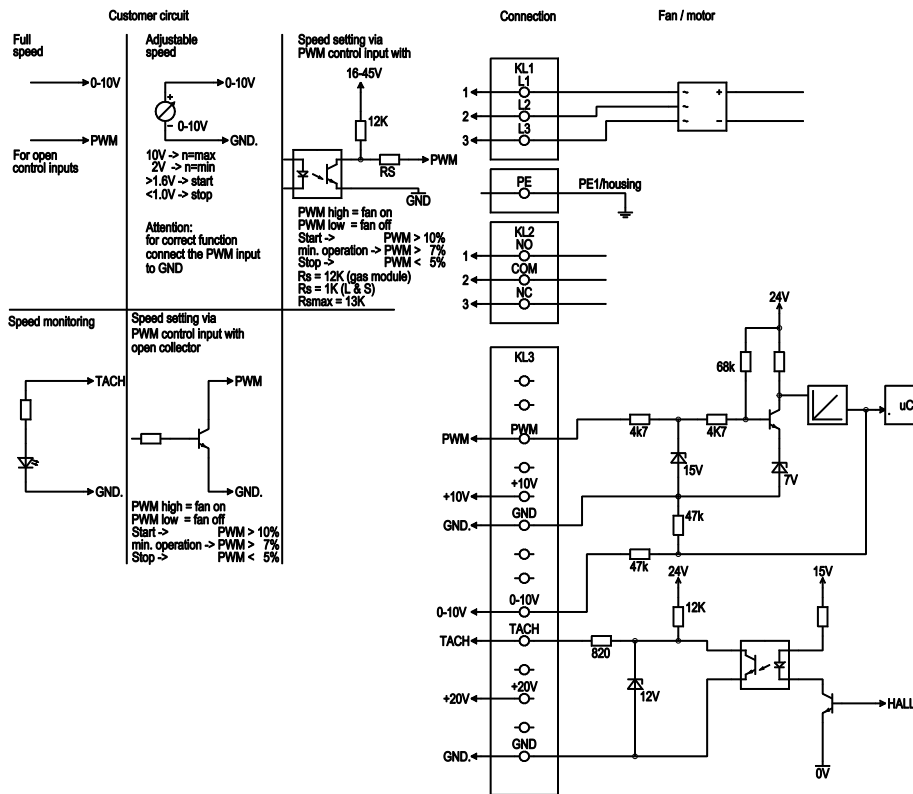

No.	Conn.	Designation	Function / assignment
1	1,2,3	L1,L2,L3	Power supply 3-phase, 50/60 Hz
		PE	Protective earth
2	1	NO	Alarm relay, make for failure
2	2	COM	Alarm relay, common connection (2A, 250VAC, AC1)
2	3	NC	Alarm relay, break for failure
3	PWM	PWM	Set value input via PWM; 16-45 V high level; 1-10 kHz; can be used exclusively as an alternative to connection 0-10 V
3	GND	GND	Signal ground for control interface
3	GND	GND	Signal ground for control interface
3	0 - 10 V	0 - 10 V	Analogue setpoint input, 0 - 10 V (impedance 100 kΩ), can be used exclusively as an alternative to connection PWM; for correct function, the PWM input must be bridged with GND.
3	+ 20 V	+ 20 V	Supply for external sensor; 20 VDC(±20%) max. 50 mA
3	+ 10 V	+ 10 V	Supply for external potentiometer, 10 VDC(±10%) max. 10 mA
3	Tach	Tach	Speed monitoring output; 12 VDC(±10%) max. 10 mA; impedance 1 kΩ; 4 pulses / revolution



# EC centrifugal fan

backward curved, single inlet

with housing (flange), Gas blower for gas-condensing heating

## Charts: Air flow 50 Hz

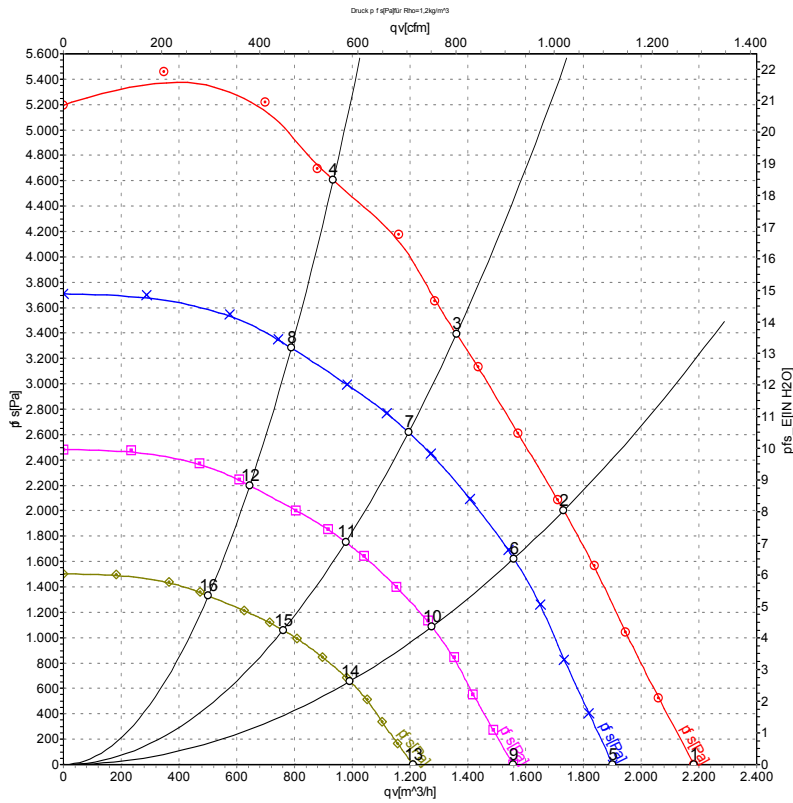

Air performance measured as per ISO 5801 Installation category A. For detailed information on the measuring set-up, please contact ebmpapst. Suction-side noise levels: LwA measured as per ISO 13347 / LpA measured with 1m distance to fan axis. The values given are valid under the measuring conditions mentioned above and may vary according to the actual installation situation. With any deviation from the standard set-up, the specific values have to be checked and reviewed with the unit installed.

## Measured values

	U	f	n	P <sub>ed</sub>	I	LwA <sub>in</sub>	qv	p <sub>fs</sub>
	V	Hz	min <sup>-1</sup>	W	A	dB(A)	m <sup>3</sup> /h	Pa
1	400	50	6315	2301	3.75	100	2185	0
2	400	50	6100	2400	4.00	96	1730	2000
3	400	50	6260	2343	3.80	94	1360	3400
4	400	50	6505	2063	3.40	92	935	4600
5	400	50	5500	1522	2.32		1900	0
6	400	50	5500	1755	2.67		1560	1628
7	400	50	5500	1588	2.38		1195	2617
8	400	50	5500	1247	1.89		790	3286
9	400	50	4500	834	1.27		1555	0
10	400	50	4500	961	1.46		1275	1090
11	400	50	4500	870	1.30		980	1752
12	400	50	4500	683	1.04		645	2200
13	400	50	3500	392	0.60		1210	0
14	400	50	3500	452	0.69		990	659
15	400	50	3500	409	0.61		760	1060
16	400	50	3500	321	0.49		500	1331

U = Supply voltage · f = Frequency · n = Speed · P<sub>ed</sub> = Power input · I = Current draw · LwA<sub>in</sub> = Sound power level inlet side · qv = Air flow · p<sub>fs</sub> = Pressure increase

