

G3G250-GN44-03

EC centrifugal fan

backward curved, single inlet
with housing (flange)



G3G250-GN44-03 ebmpapst Datasheet

sales@fansco.com

www.fansco.com

Nominal data

Type	G3G250-GN44-03	
Motor	M3G084-FA	
Phase		1~
Nominal voltage	VAC	230
Nominal voltage range	VAC	208 .. 240
Frequency	Hz	50/60
Type of data definition		ml
Valid for approval / standard		UL
Speed	min ⁻¹	4500
Power input	W	860
Current draw	A	4.8 @ 208 V
Min. ambient temperature	°C	-20
Max. ambient temperature	°C	60
Min. temp. of flow medium	°C	0
Max. temp. of flow medium	°C	60

ml = max. load · me = max. efficiency · fa = running at free air · cs = customer specs · cu = customer unit
Subject to alterations

Data according to ErP directive

Installation category	A
Efficiency category	Static
Variable speed drive	Yes
Specific ratio*	1.02

* Specific ratio = $1 + p_{fs} / 100\,000\text{ Pa}$

	Actual	Request 2013	Request 2015
Overall efficiency η_{es}	61.7	46.5	49.5
Efficiency grade N	73.2	58	61
Power input P_{ed}	kW	0.81	
Air flow q_v	m ³ /h	795	
Pressure increase p_{fs}	Pa	2101	
Speed n	min ⁻¹	4530	

Data established at point of optimum efficiency



EC centrifugal fan

backward curved, single inlet
with housing (flange)

Technical features

Mass	13 kg
Size	250 mm
Surface of rotor	Coated in black
Material of protective cover	Polyflam RPP 374-ND CS1 (UL 97-V0)
Material of impeller	Aluminium sheet
Housing material	Die-cast aluminium
Number of blades	7
Direction of rotation	Clockwise, seen on rotor
Type of protection	IP 20
Insulation class	"B"
Max. permissible ambient motor temp. (transp./ storage)	+80 °C
Min. permissible ambient motor temp. (transp./storage)	-40 °C
Mounting position	Any
Condensate discharge holes	Rotor-side
Operation mode	S1
Motor bearing	Ball bearing
Technical features	<ul style="list-style-type: none"> - Tach output - Motor current limit - Emergency operation - PFC, active - Control input 0-10 VDC PWM control input - Control interface with SELV potential safely disconnected from the mains - Over-temperature protected electronics / motor - Line undervoltage / phase failure detection
EMC interference immunity	Acc. to EN 61000-6-2 (industrial environment)
EMC harmonics	Acc. to EN 61000-3-2/3
EMC interference emission	Acc. to EN 61000-6-4 (industrial environment)
Touch current acc. IEC 60990 (measuring network Fig. 4, TN system)	<= 3.5 mA
Electrical leads	With plug
Motor protection	Locked-rotor protection
Protection class	I (if protective earth is connected by customer)
Approval	UL 507; CSA C22.2 Nr.113; CCC



EC centrifugal fan

backward curved, single inlet
with housing (flange)

Product drawing

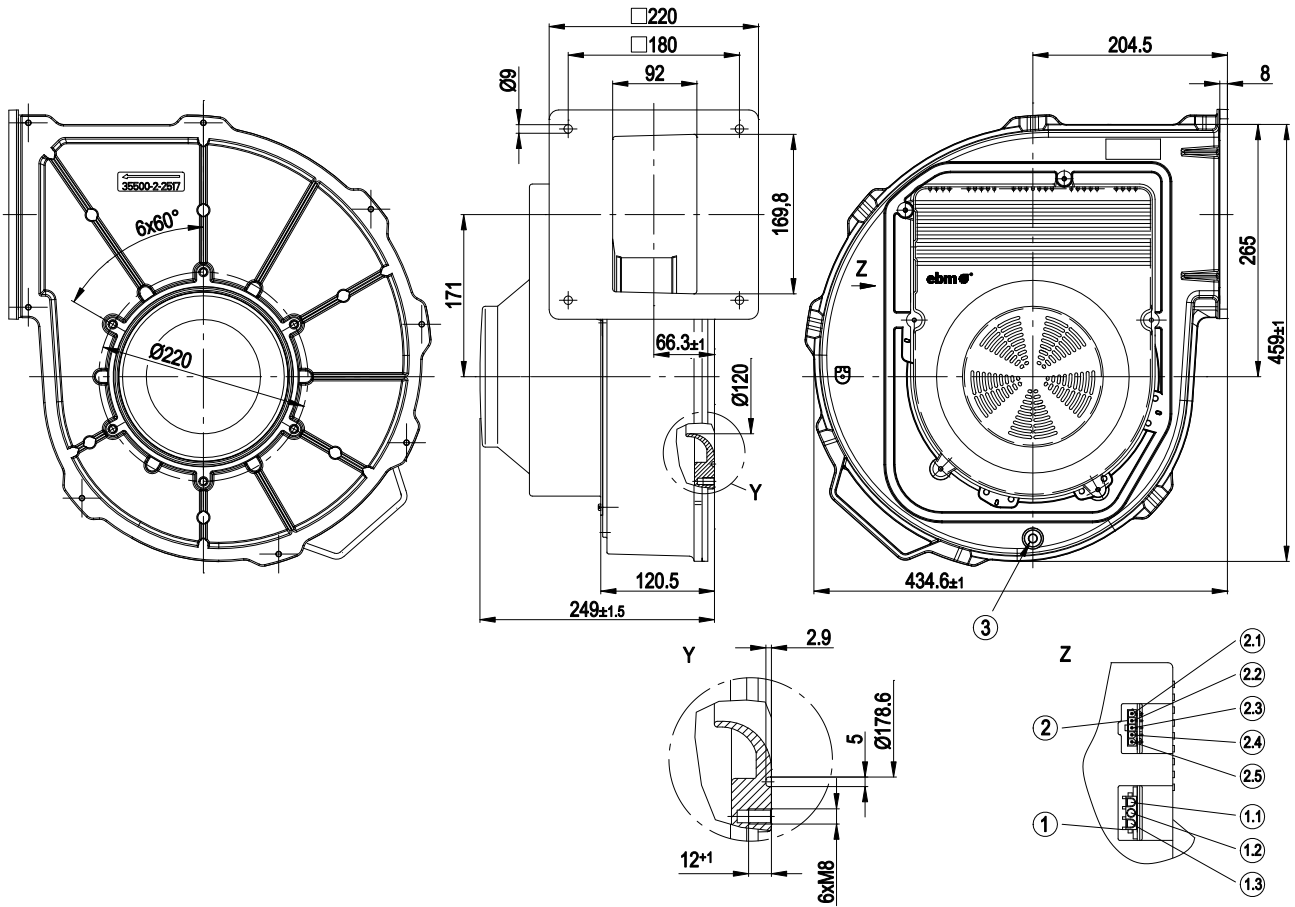

1	3-pole strip, suitable for mating connector (not included in standard scope of delivery): tyco No. 350766-1, female terminal: tyco No. 926884-1
1.1	L
1.2	N
1.3	PE
2	5-pole strip to fit mating connector (not included in standard scope of delivery) Molex No. 39-01-4050, female connector Molex No. 39-00-0059
2.1	+
2.2	Speed monitoring
2.3	0-10 VDC control input
2.4	PWM input
2.5	-
3	Pressure tap optionally available
Y	Detail Y
Z	View Z / plug assignment



EC centrifugal fan

backward curved, single inlet
with housing (flange)

Connection screen

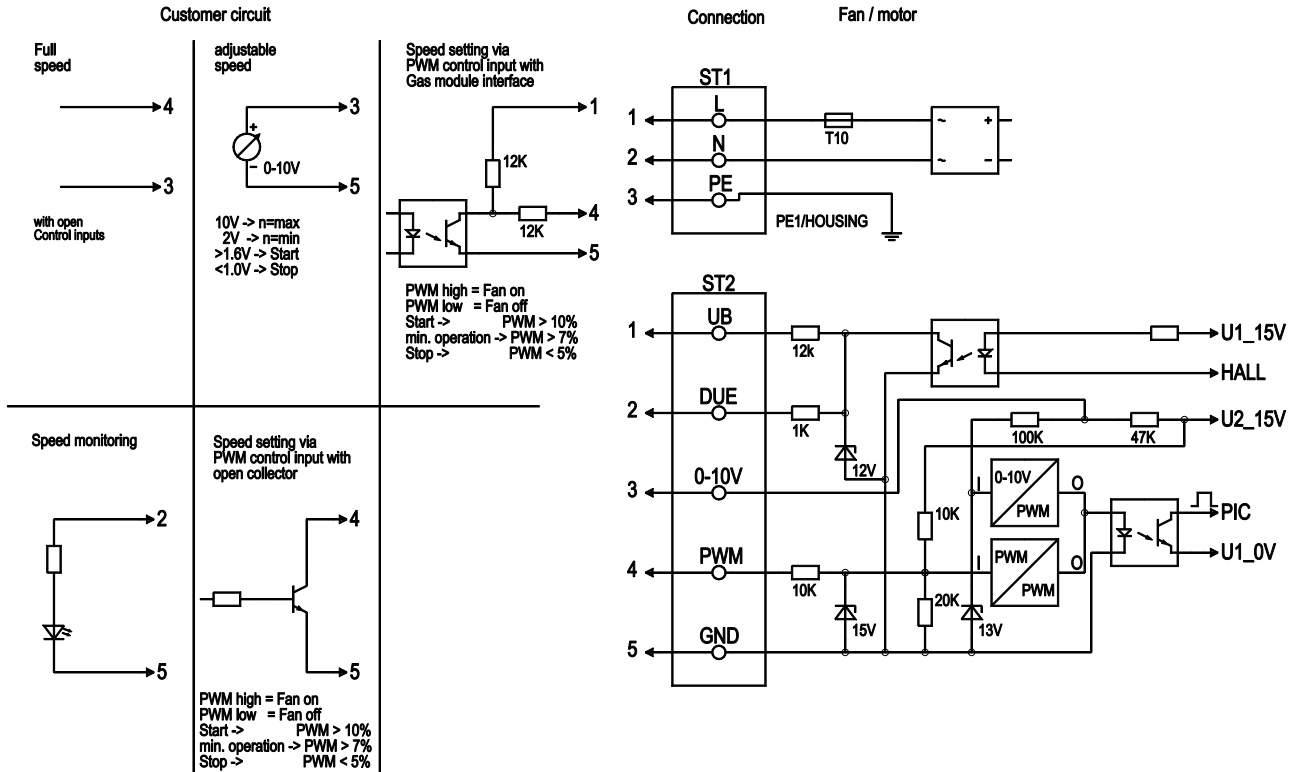

No.	Pin	Signal	Function / assignment
ST1	1; 2; 3	L; N; PE	Power supply 230 VAC, 50 - 60 Hz, phase, neutral, protective earth
St2	1	UB	External voltage 16 - 45 VDC, residual ripple +/- 3.5%, SELV
ST2	2	Tach	Speed monitoring, 3 pulses per revolution, SELV
ST2	3	0 - 10 V	Control input 0 - 10 V, impedance 100k, SELV
ST2	4	PWM	Control input PWM, 1 - 6 kHz, SELV
ST2	5	GND	GND - Connection for control interface, SELV



EC centrifugal fan

backward curved, single inlet
with housing (flange)

Charts: Air flow 50 Hz

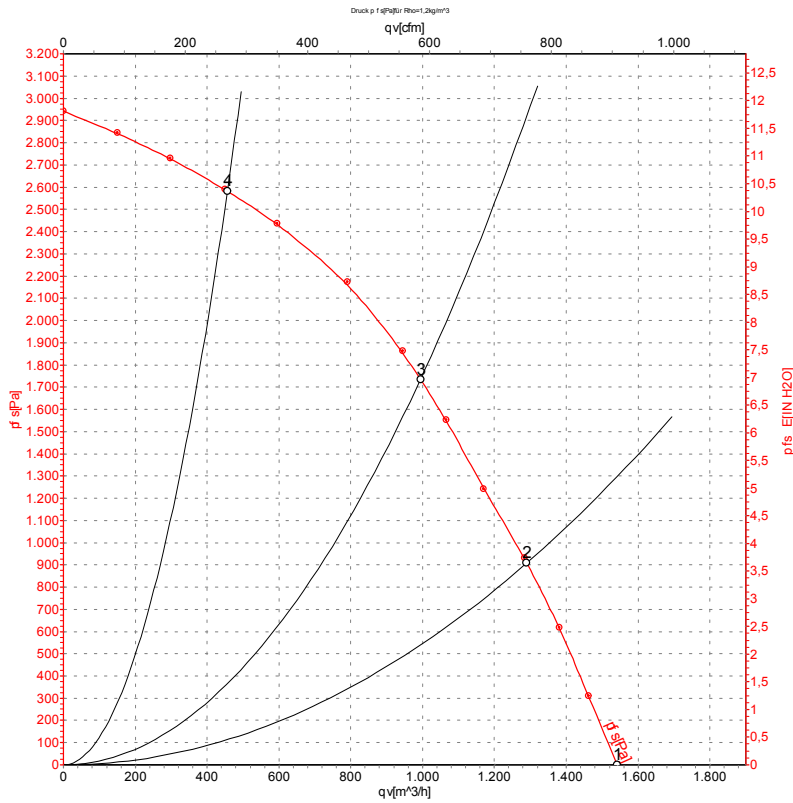

Measurement: LU-106095

Air performance measured as per ISO 5801 Installation category A. For detailed information on the measuring set-up, please contact ebmpapst. Suction-side noise levels: LwA measured as per ISO 13347 / LpA measured with 1m distance to fan axis. The values given are valid under the measuring conditions mentioned above and may vary according to the actual installation situation. With any deviation from the standard set-up, the specific values have to be checked and reviewed with the unit installed.

Measured values

	U	f	n	P _{ed}	I	LpA _{in}	qv	p _{fs}
	V	Hz	min ⁻¹	W	A	dB(A)	m ³ /h	Pa
1	230	50	4480	822	3.59	85	1540	0
2	230	50	4430	924	4.04	83	1290	915
3	230	50	4465	890	3.90	78	995	1736
4	230	50	4655	663	2.90	78	455	2583

U = Supply voltage · f = Frequency · n = Speed · P_{ed} = Power input · I = Current draw · LpA_{in} = Sound pressure level inlet side · qv = Air flow · p_{fs} = Pressure increase

