

EC centrifugal fan

forward curved, single inlet

with housing (flange)

G3G146-HK07-15 ebmpapst Datasheet

sales@fansco.com

www.fansco.com

Limited partnership · Headquarters Mulfingen
County court Stuttgart · HRA 590344

General partner Elektrobau Mulfingen GmbH · Headquarters Mulfingen
County court Stuttgart · HRB 590142

Nominal data

Type	G3G146-HK07-15	
Motor	M3G055-DF	
Phase		1~
Nominal voltage	VAC	230
Nominal voltage range	VAC	200 .. 240
Frequency	Hz	50/60
Type of data definition		fa
Speed (rpm)	min ⁻¹	2255
Power input	W	163
Current draw	A	1.3
Min. back pressure	Pa	0
Min. ambient temperature	°C	-25
Max. ambient temperature	°C	60

ml = Max. load · me = Max. efficiency · fa = Running at free air · cs = Customer specs · cu = Customer unit
Subject to alterations

Data according to ErP directive

		Actual	Request 2015		
01 Overall efficiency η_{es}	%	39.4	32.1	09 Power input P_{ed}	kW
02 Measurement category		A		09 Air flow q_v	m ³ /h
03 Efficiency category		Static		09 Pressure increase p_{fs}	Pa
04 Efficiency grade N		51.3	44	10 Speed (rpm) n	min ⁻¹
05 Variable speed drive		No		11 Specific ratio [*]	
					1.01

Data definition with optimum efficiency.

The ErP data is determined using a motor-impeller combination in a standardised measurement configuration.

^{*} Specific ratio = $1 + p_{fs} / 100\,000\text{ Pa}$

LU-139323



EC centrifugal fan

forward curved, single inlet
with housing (flange)

Technical features

Mass	3.05 kg
Size	146 mm
Surface of rotor	Thick layer passivated
Material of terminal box	Die-cast aluminium
Material of impeller	Sheet steel, galvanised
Housing material	Sheet steel, galvanised
Direction of rotation	Clockwise, seen on rotor
Type of protection	IP 54
Insulation class	"B"
Max. permissible ambient motor temp. (transp./ storage)	+ 80 °C
Min. permissible ambient motor temp. (transp./storage)	- 40 °C
Mounting position	Any
Condensate discharge holes	None, open rotor
Cooling bore / aperture	Rotor-side
Operation mode	S1
Motor bearing	Ball bearing
Technical features	<ul style="list-style-type: none"> - Output limit - Motor current limit - Soft start - Overvoltage detection - Over-temperature protected electronics / motor
EMC interference immunity	Acc. to EN 61000-6-2 (industrial environment)
EMC interference emission	Acc. to EN 61000-6-4 (industrial environment)
Touch current acc. IEC 60990 (measuring network Fig. 4, TN system)	<= 3.5 mA
Electrical leads	Via terminal box
Motor protection	Locked-rotor protection
Cable exit	Variable
Protection class	I (if protective earth is connected by customer)
Product conforming to standard	EN 60335-1; CE
Approval	CCC



EC centrifugal fan

forward curved, single inlet
with housing (flange)

Product drawing

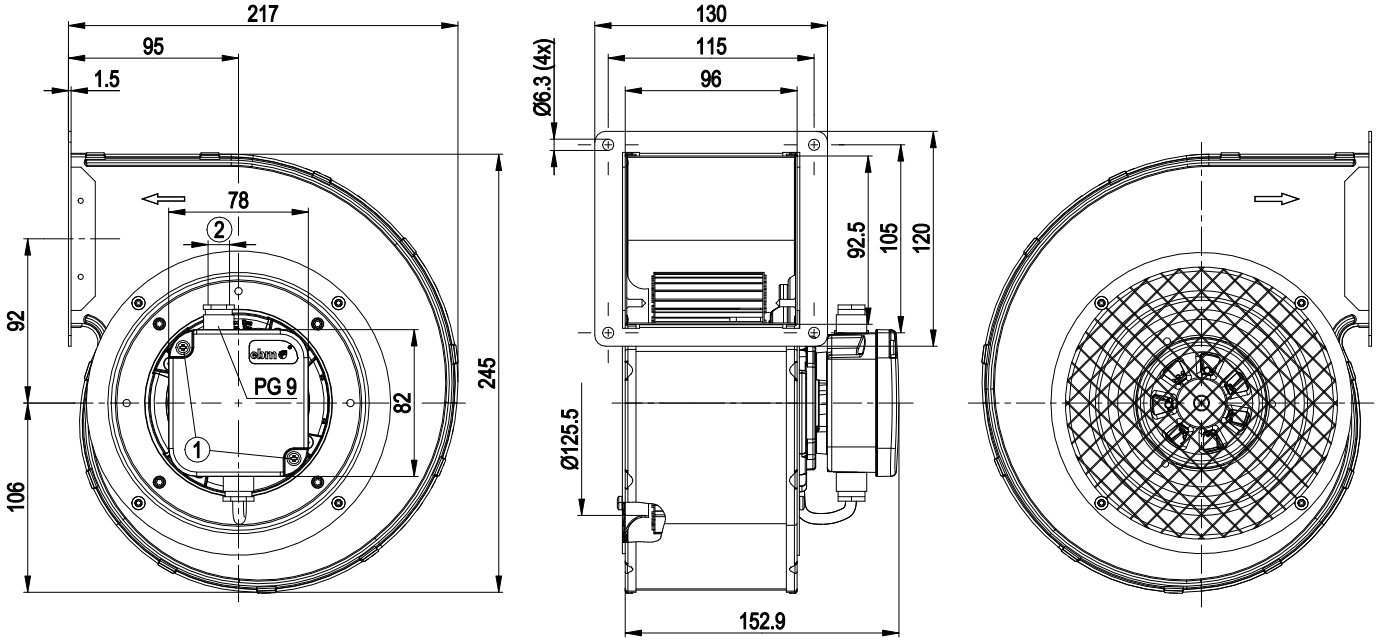

- | | |
|---|--|
| 1 | Tightening torque 1.3±0.2 Nm |
| 2 | Cable diameter min. 6 mm, max. 8 mm, tightening torque 2±0.3Nm |



EC centrifugal fan

forward curved, single inlet
with housing (flange)

Connection screen

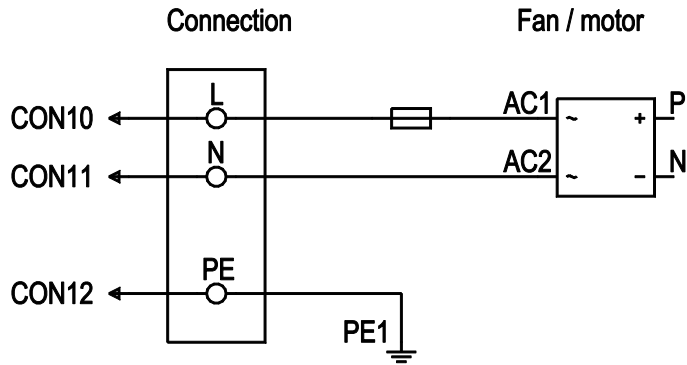

No.	Conn.	Designation	Colour	Function / assignment
	CON 10	L	black	Power supply 230 VAC, 50 - 60 Hz, for voltage range refer to rating plate
	CON 11	N	blue	Neutral conductor
	CON 12	PE	green/yellow	Protective earth



EC centrifugal fan

forward curved, single inlet

with housing (flange)

Charts: Air flow 50 Hz

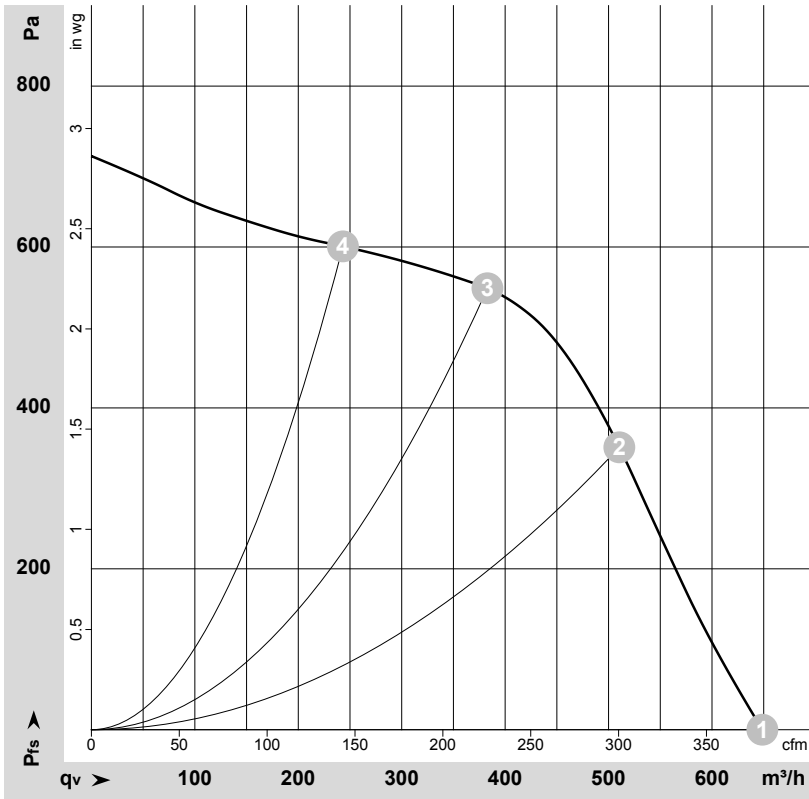

$\rho = 1.15 \text{ kg/m}^3 \pm 2 \%$

Measurement: LU-139323-1

Air performance measured as per ISO 5801 Installation category A. For detailed information on the measuring set-up, please contact ebmpapst. Suction-side noise levels: LwA measured as per ISO 13347 / LpA measured with 1m distance to fan axis. The values given are valid under the measuring conditions mentioned above and may vary according to the actual installation situation. With any deviation from the standard set-up, the specific values have to be checked and reviewed with the unit installed.

Measured values

	U	f	n	P _{ed}	I	LpA _{in}	LwA _{in}	q _v	p _{fs}	q _v	p _{fs}
	V	Hz	min ⁻¹	W	A	dB(A)	dB(A)	m ³ /h	Pa	cfm	inH ₂ O
1	230	50	2255	163	1.30	70	77	650	0	380	0.00
2	230	50	2690	163	1.30	68	75	510	350	300	1.41
3	230	50	3015	149	1.22	67	74	385	550	225	2.21
4	230	50	3165	113	0.96	68	75	245	600	145	2.41

U = Supply voltage · f = Frequency · n = Speed (rpm) · P_{ed} = Power input · I = Current draw · LpA_{in} = Sound pressure level inlet side · LwA_{in} = Sound power level inlet side · q_v = Air flow
p_{fs} = Pressure increase

