

# EC centrifugal fan

forward curved, single inlet

with housing (flange)

G3G146-ED17-08 ebmpapst Datasheet

[sales@fansco.com](mailto:sales@fansco.com)

[www.fansco.com](http://www.fansco.com)

Limited partnership · Headquarters Muldingen  
County court Stuttgart · HRA 590344

General partner Elektrobau Muldingen GmbH · Headquarters Muldingen  
County court Stuttgart · HRB 590142

## Nominal data

Type	G3G146-ED17-08	
Motor	M3G055-CF	
Nominal voltage	VDC	380
Nominal voltage range	VDC	370 .. 390
Type of data definition		fa
Speed	min <sup>-1</sup>	1870
Power input	W	122
Current draw	A	0.55
Min. ambient temperature	°C	-25
Max. ambient temperature	°C	40

ml = Max. load · me = Max. efficiency · fa = Running at free air · cs = Customer specs · cu = Customer unit  
Subject to alterations



# EC centrifugal fan

forward curved, single inlet  
with housing (flange)

## Technical features

Mass	2.6 kg
Size	146 mm
Surface of rotor	Thick layer passivated
Material of impeller	Sheet steel, galvanised
Housing material	Sheet steel, galvanised
Direction of rotation	Clockwise, seen on rotor
Type of protection	IP 54; Depending on installation and position
Insulation class	"B"
Humidity class	F3-1
Max. permissible ambient motor temp. (transp./ storage)	+ 80 °C
Min. permissible ambient motor temp. (transp./storage)	- 40 °C
Mounting position	Any
Condensate discharge holes	None, open rotor
Operation mode	S1
Motor bearing	Ball bearing
Technical features	<ul style="list-style-type: none"> <li>- Output 10 VDC, max. 1.1 mA</li> <li>- Tach output</li> <li>- Motor current limit</li> <li>- Soft start</li> <li>- Control input 0-10 VDC / PWM</li> <li>- Control interface with SELV potential safely disconnected from the mains</li> <li>- Over-temperature protected motor</li> </ul>
EMC interference immunity	Acc. to EN 61000-6-2 (industrial environment)
EMC harmonics	Acc. to EN 61000-3-2/3
EMC interference emission	Must be assessed in customer unit
Leakage current (meas. network acc. IEC 60990, fig.4, TN sys.); normal operation	<= 3.5 mA
Motor protection	Locked-rotor protection
Cable exit	Variable
Protection class	I (if protective earth is connected by customer)
Product conforming to standard	EN 60335-1





# EC centrifugal fan

forward curved, single inlet  
with housing (flange)

## Connection screen

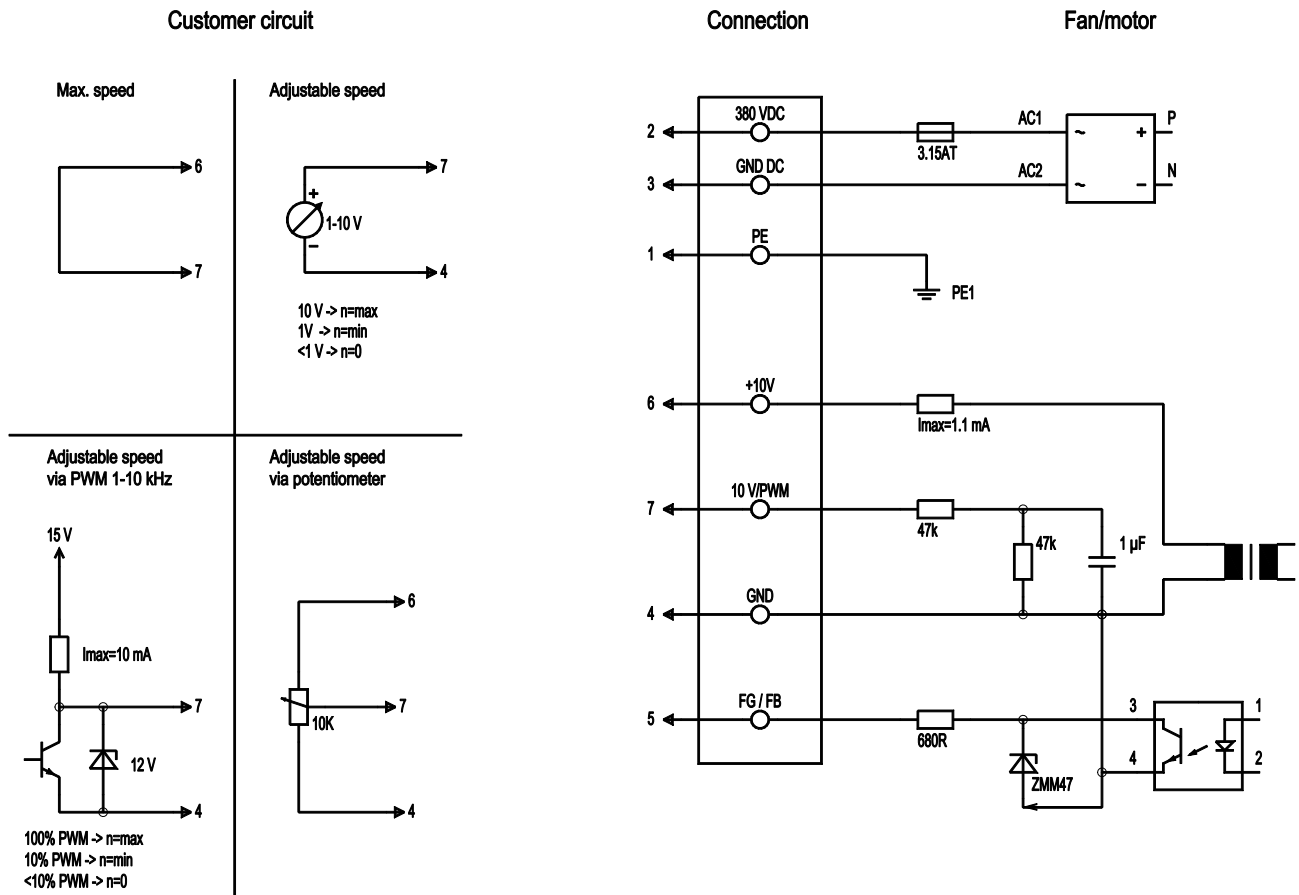

Line	No.	Signal	Colour	Function / assignment
	2	380 VDC	brown	Power supply 380 VDC, see type plate for voltage range
	3	GND DC	blue	GND connection
	1	PE	green/yellow	Protective earth
	6	10V/ max 1.1mA	red	Voltage output 10 V / 1.1mA, electrically isolated, not short-circuit-proof.
	7	0-10V PWM	yellow	Control input 0 - 10 V or PWM, electrically isolated
	4	GND	blue	GND connection for control interface
	5	FG / FB	white	Fan good low signal, Fan bad high signal, Open Collector, electrically isolated
				Important! Device may only be operated with control unit 61423-1-0173. This is not included in the scope of delivery.



# EC centrifugal fan

forward curved, single inlet

with housing (flange)

## Charts: Air flow 50 Hz

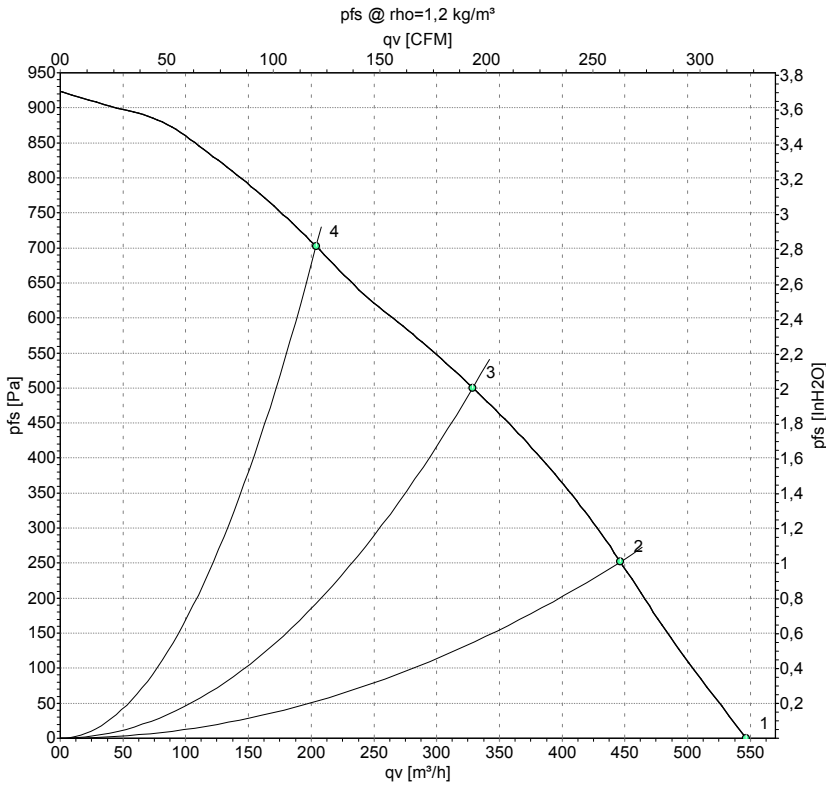

Measurement: LU-154750

Air performance measured as per ISO 5801 Installation category A. For detailed information on the measuring set-up, please contact ebm-papst. Suction-side noise levels: LwA measured as per ISO 13347 / LpA measured with 1m distance to fan axis. The values given are valid under the measuring conditions mentioned above and may vary according to the actual installation situation. With any deviation from the standard set-up, the specific values have to be checked and reviewed with the unit installed.

## Measured values

	U	f	n	P <sub>ed</sub>	I	LpA <sub>in</sub>	LwA <sub>in</sub>	qv	p <sub>fs</sub>
	V	Hz	min <sup>-1</sup>	W	A	dB(A)	dB(A)	m³/h	Pa
1	230	50	1930	120	0.53	66	72	545	0
2	230	50	2280	120	0.53	65	71	445	250
3	230	50	2755	120	0.53	66	72	330	500
4	230	50	3360	120	0.53	69	75	205	700

U = Supply voltage · f = Frequency · n = Speed · P<sub>ed</sub> = Power input · I = Current draw · LpA<sub>in</sub> = Sound pressure level inlet side · LwA<sub>in</sub> = Sound power level inlet side · qv = Air flow  
 p<sub>fs</sub> = Pressure increase

