

EC centrifugal fan

forward curved, single inlet

with housing (flange)

G3G140-PV17-18 ebmpapst Datasheet

sales@fansco.com

www.fansco.com

Limited partnership · Headquarters Muldingen
County court Stuttgart · HRA 590344

General partner Elektrobau Muldingen GmbH · Headquarters Muldingen
County court Stuttgart · HRB 590142

Nominal data

Type	G3G140-PV17-18	
Motor	M3G055-CF	
Phase		1~
Nominal voltage	VAC	230
Frequency	Hz	50/60
Type of data definition		ml
Speed (rpm)	min ⁻¹	2680
Power input	W	105
Current draw	A	0.83
Min. back pressure	Pa	400
Min. ambient temperature	°C	-25
Max. ambient temperature	°C	50

ml = Max. load · me = Max. efficiency · fa = Running at free air · cs = Customer specs · cu = Customer unit
Subject to alterations



EC centrifugal fan

forward curved, single inlet

with housing (flange)

Technical features

Mass	2.3 kg
Size	140 mm
Surface of rotor	Thick layer passivated
Material of impeller	Sheet steel, galvanised
Housing material	Sheet steel, galvanised
Direction of rotation	Counter-clockwise, seen on rotor
Type of protection	IP 44; Depending on installation and position as per EN 60034-5
Insulation class	"B"
Humidity (F)/environmental protection class (H)	F3-1
Max. permissible ambient motor temp. (transp./ storage)	+ 80 °C
Min. permissible ambient motor temp. (transp./storage)	- 40 °C
Mounting position	Any
Condensate discharge holes	Rotor-side
Operation mode	S1
Motor bearing	Ball bearing
Technical features	<ul style="list-style-type: none"> - Output 10 VDC, max. 1.1 mA - Tach output - Motor current limit - Soft start - Control input 0-10 VDC / PWM - Control interface with SELV potential safely disconnected from the mains - Over-temperature protected motor
EMC interference immunity	Acc. to EN 61000-6-2 (industrial environment)
EMC harmonics	Acc. to EN 61000-3-2/3
EMC interference emission	Acc. to EN 61000-6-3 (household environment)
Touch current acc. IEC 60990 (measuring network Fig. 4, TN system)	<= 3.5 mA
Motor protection	Thermal overload protector (TOP) wired internally
Cable exit	Variable
Protection class	I (if protective earth is connected by customer)
Product conforming to standard	EN 60335-1; CE



EC centrifugal fan

forward curved, single inlet
with housing (flange)

Product drawing

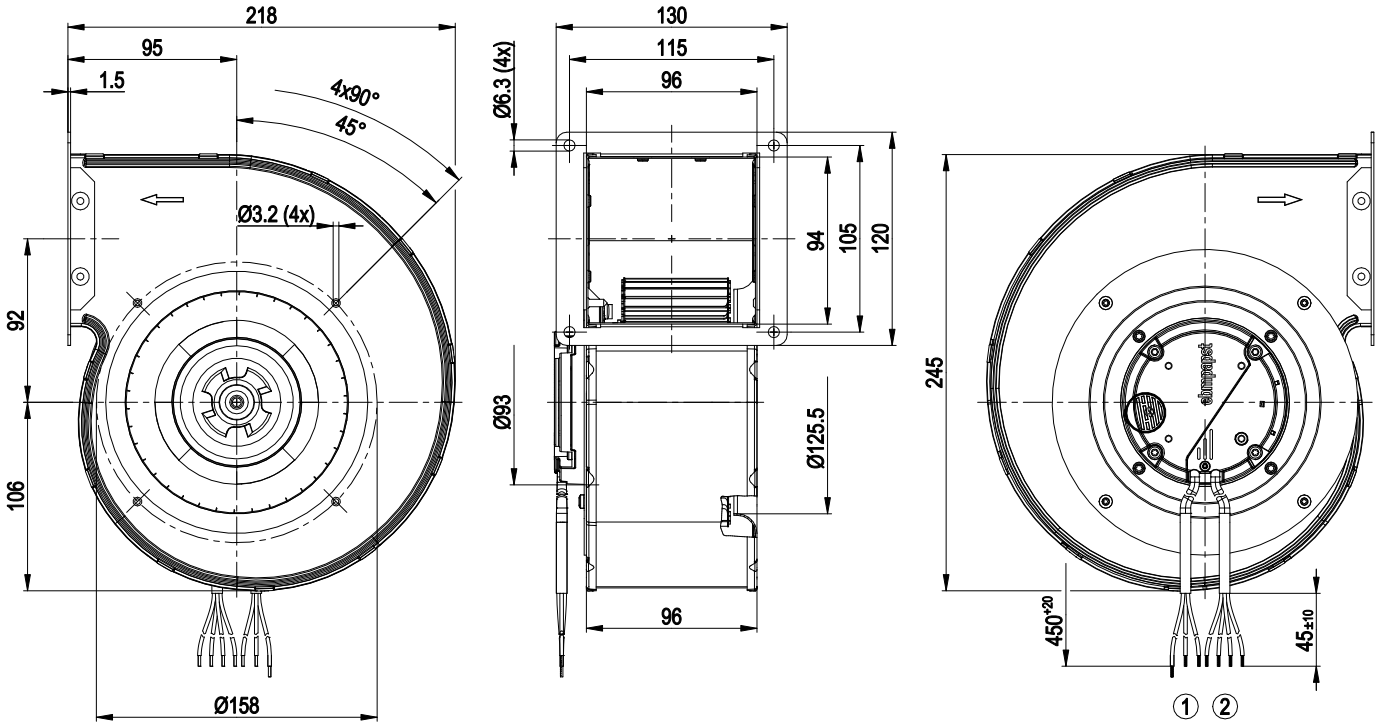

- | | |
|---|--|
| 1 | Connection line PVC 3G 0.5 mm ² , 3x lead tips crimped |
| 2 | Connection line PVC 4x 0.25 mm ² , 4x lead tips crimped |



EC centrifugal fan

forward curved, single inlet
with housing (flange)

Connection screen

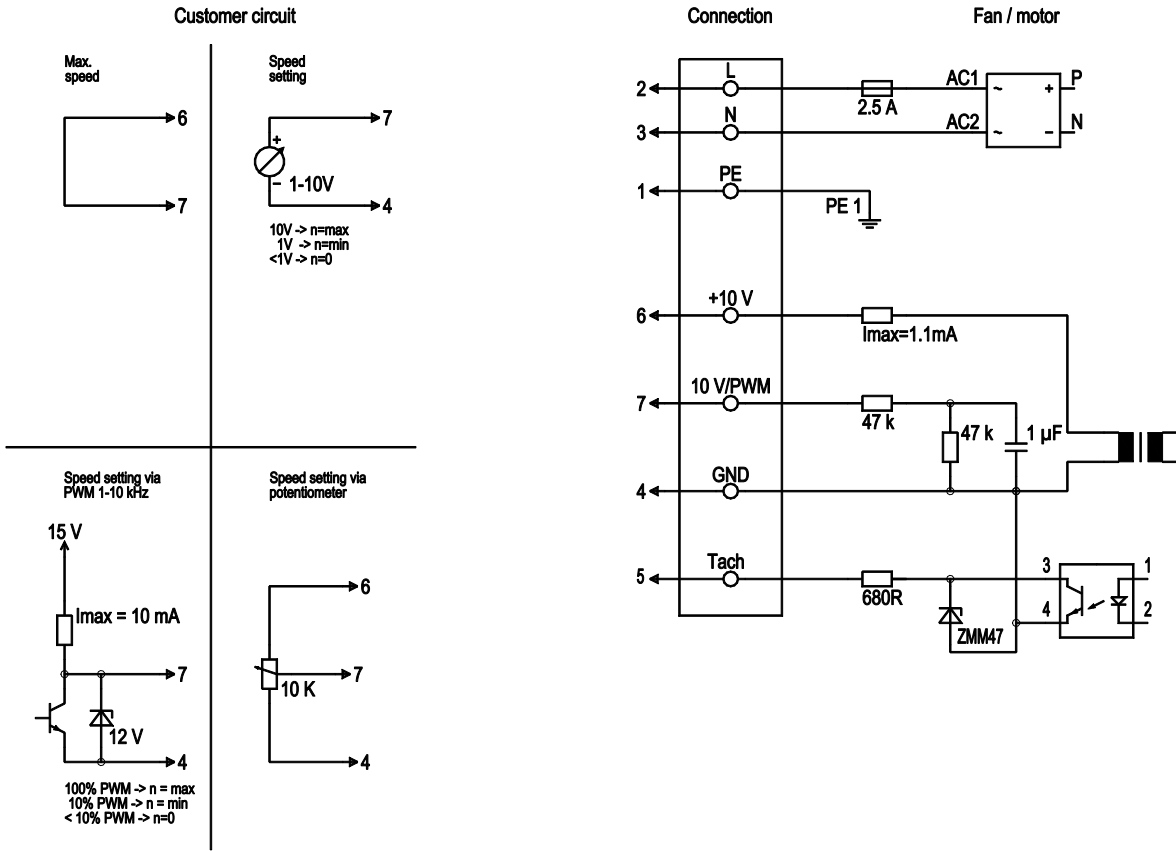

No.	Conn.	Designation	Colour	Function / assignment
	2	L	brown	Power supply 230 VAC, 50-60 Hz, see type plate for voltage range
	3	N	blue	Neutral conductor
	1	PE	green/yellow	Protective earth
	7	0-10 V PWM	yellow	Control input 0 - 10 V or PWM, electrically isolated
	5	Tach	white	Tach output: Open Collector, 1 pulse per revolution, electrically isolated
	6	10V / max. 1.1 mA	red	Voltage output 10V / 1.1mA, electrically isolated, not short-circuit-proof
	4	GND	blue	GND - Connection for control interface



EC centrifugal fan

forward curved, single inlet

with housing (flange)

Charts: Air flow 50 Hz

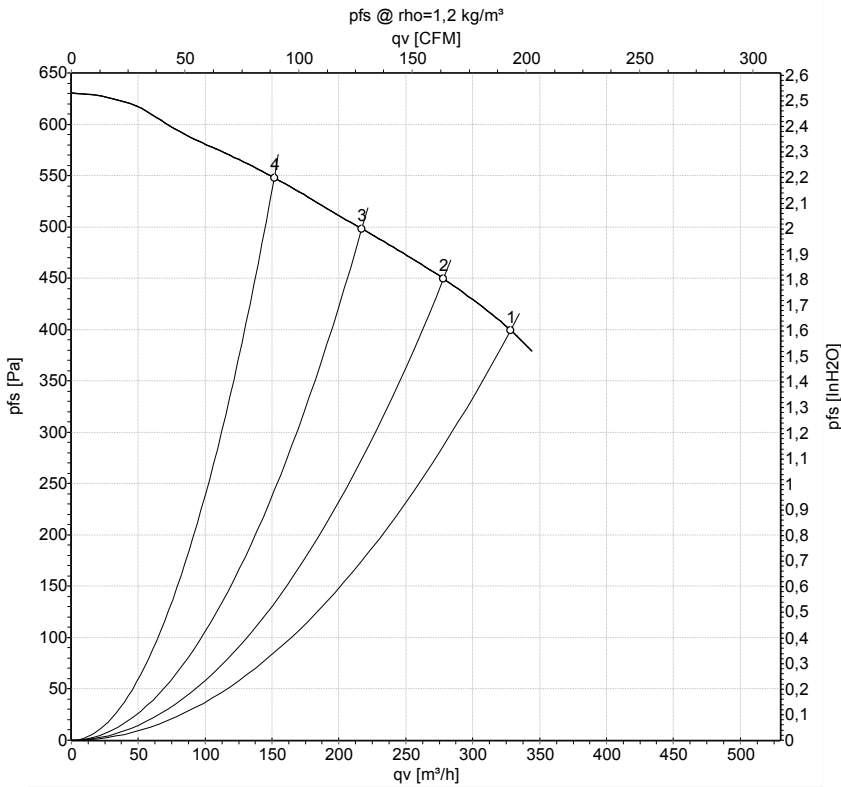

Measurement: LU-139533-1

Air performance measured as per ISO 5801 Installation category A. For detailed information on the measuring set-up, please contact ebm-papst. Suction-side noise levels: LwA measured as per ISO 13347 / LpA measured with 1m distance to fan axis. The values given are valid under the measuring conditions mentioned above and may vary according to the actual installation situation. With any deviation from the standard set-up, the specific values have to be checked and reviewed with the unit installed.

Measured values

	U	f	n	P _{ed}	I	LpA _{in}	LwA _{in}	q _v	p _{fs}	q _v	p _{fs}
	V	Hz	min ⁻¹	W	A	dB(A)	dB(A)	m³/h	Pa	cfm	inH2O
1	230	50	2680	105	0.83	64	70	330	400	195	1.61
2	230	50	2800	97	0.79	64	70	280	450	165	1.81
3	230	50	2930	85	0.70	65	72	215	500	130	2.01
4	230	50	3095	75	0.62	66	73	150	550	90	2.21

U = Supply voltage · f = Frequency · n = Speed (rpm) · P_{ed} = Power input · I = Current draw · LpA_{in} = Sound pressure level inlet side · LwA_{in} = Sound power level inlet side · q_v = Air flow
 p_{fs} = Pressure increase

