

EC centrifugal fan

forward curved, single inlet

with housing (flange)

G3G140-PV05-23 ebmpapst Datasheet

sales@fansco.com

www.fansco.com

Limited partnership · Headquarters Muldingen
County court Stuttgart · HRA 590344

General partner Elektrobau Muldingen GmbH · Headquarters Muldingen
County court Stuttgart · HRB 590142

Nominal data

Type	G3G140-PV05-23	
Motor	M3G055-CF	
Phase		1~
Nominal voltage	VAC	230
Nominal voltage range	VAC	200 .. 240
Frequency	Hz	50/60
Type of data definition		fa
Speed (rpm)	min ⁻¹	1750
Power input	W	68
Current draw	A	0.6
Min. back pressure	Pa	0
Min. ambient temperature	°C	-25
Max. ambient temperature	°C	55

ml = Max. load · me = Max. efficiency · fa = Running at free air · cs = Customer specs · cu = Customer unit
Subject to alterations



EC centrifugal fan

forward curved, single inlet
with housing (flange)

Technical features

Mass	2.5 kg
Size	140 mm
Surface of rotor	Thick layer passivated
Material of impeller	Sheet steel, galvanised
Housing material	Sheet steel, galvanised
Direction of rotation	Counter-clockwise, seen on rotor
Type of protection	IP 54
Insulation class	"B"
Humidity (F)/environmental protection class (H)	H1
Max. permissible ambient motor temp. (transp./ storage)	+ 80 °C
Min. permissible ambient motor temp. (transp./storage)	- 40 °C
Mounting position	Any
Condensate discharge holes	None, open rotor
Operation mode	S1
Motor bearing	Ball bearing
Technical features	<ul style="list-style-type: none"> - Output 10 VDC, max. 10 mA - Tach output - Output limit - Motor current limit - Soft start - Control input 0-10 VDC / PWM - Control interface with SELV potential safely disconnected from the mains - Overvoltage detection - Over-temperature protected electronics / motor - Line undervoltage detection
EMC interference immunity	Acc. to EN 61000-6-2 (industrial environment)
EMC harmonics	Acc. to EN 61000-3-2/3
EMC interference emission	Acc. to EN 61000-6-3 (household environment)
Touch current acc. IEC 60990 (measuring network Fig. 4, TN system)	<= 3.5 mA
Motor protection	Locked-rotor protection
Cable exit	Variable
Protection class	I (if protective earth is connected by customer)
Product conforming to standard	EN 60335-1; CE



EC centrifugal fan

forward curved, single inlet
with housing (flange)

Product drawing

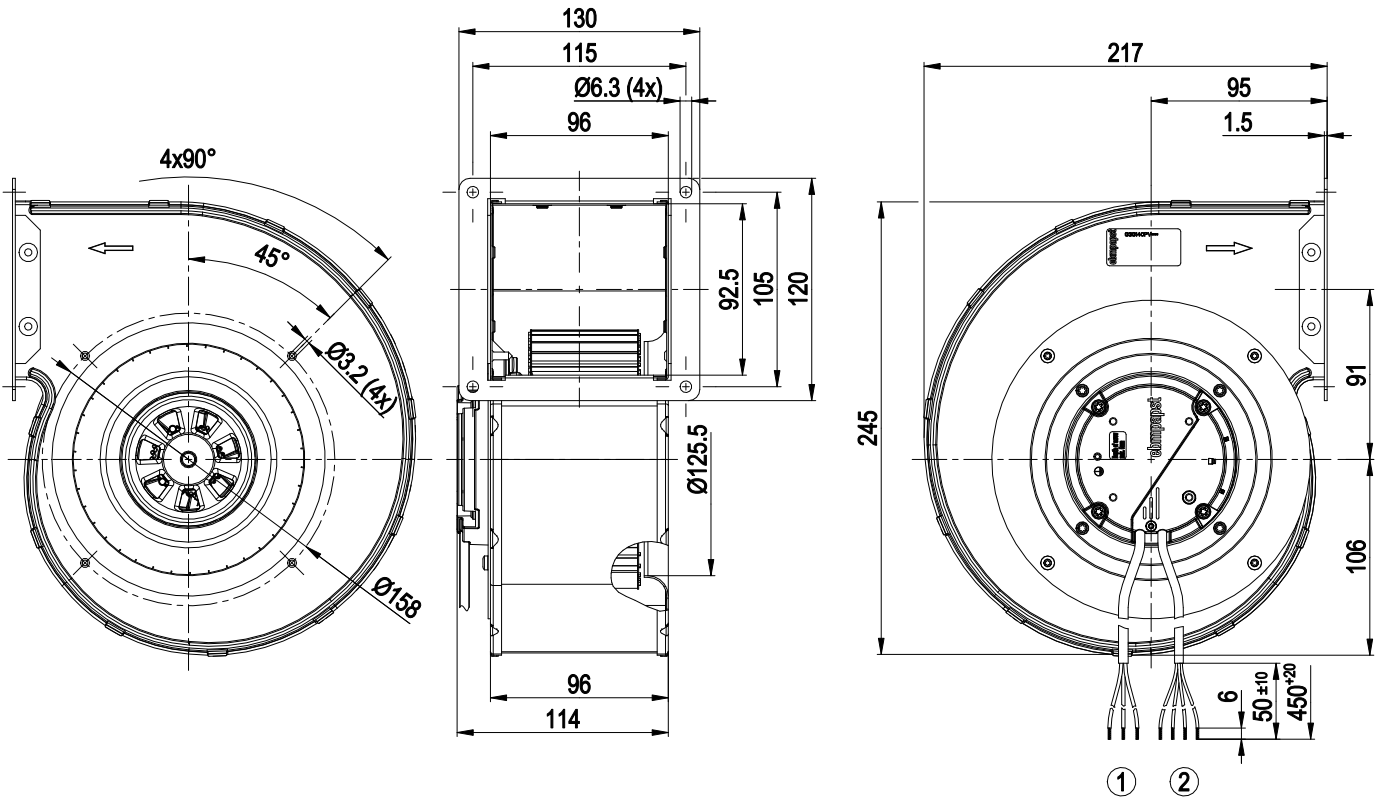

- | | |
|---|--|
| 1 | Connection line halogen-free 3G 0.5 mm ² , 3x lead tips crimped |
| 2 | Connection line halogen-free, 4x 0.25 mm ² , 4x lead tips crimped |



EC centrifugal fan

forward curved, single inlet
with housing (flange)

Connection screen

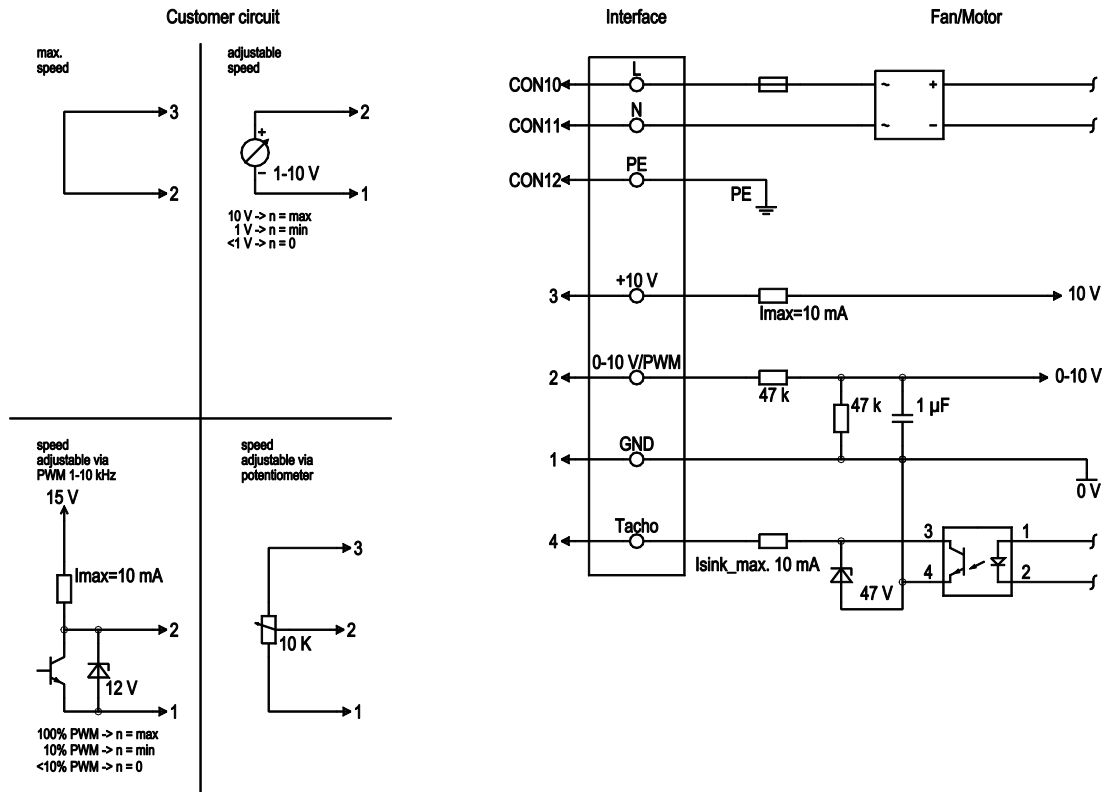

No.	Conn.	Designation	Colour	Function / assignment
	CON10	L	brown	Mains connection, power supply, phase, see type plate for voltage range
	CON11	N	blue	Mains connection, power supply, neutral conductor, see type plate for voltage range
	CON12	PE	green/yellow	Earth connection
	2	0- 10V PWM	yellow	0-10 V/PWM control input, R _i =100 kΩ, SELV
	4	Tach	white	Speed monitoring output, open collector, 1 pulse per revolution, I _{sink max} = 10 mA, SELV
	3	+10 V	red	Fixed voltage output 10 VDC +/-3 %, I _{max.} 10 mA, short-circuit-proof, power supply for ext. devices (e.g. potentiometer), SELV
	1	GND	blue	Signal ground for control interface, SELV



EC centrifugal fan

forward curved, single inlet
with housing (flange)

Charts: Air flow 50 Hz

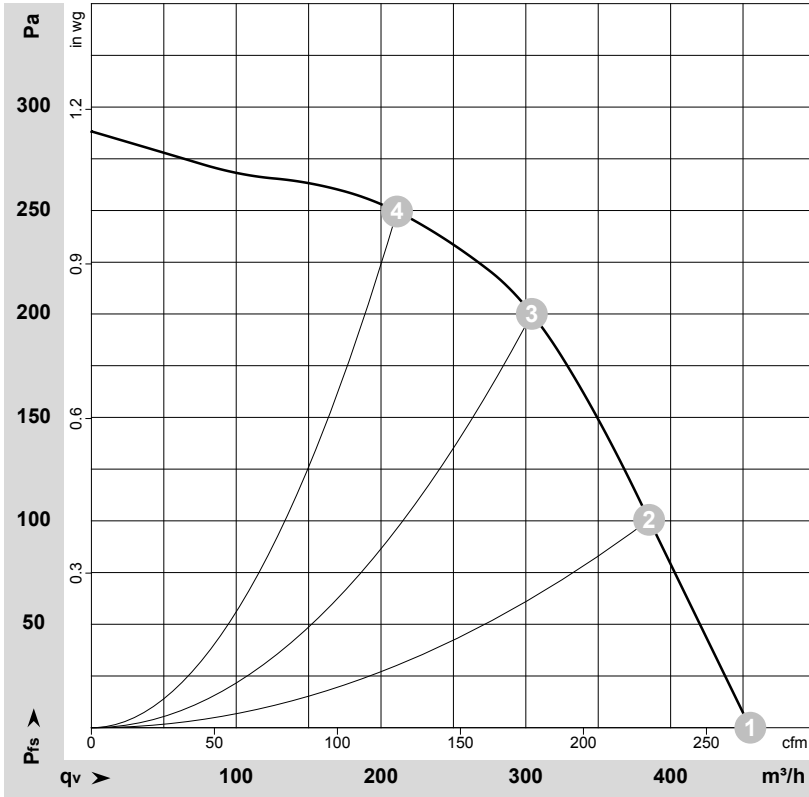

$\rho = 1.15 \text{ kg/m}^3 \pm 2 \%$

Measurement: LU-177528-1

Air performance measured as per ISO 5801 Installation category A. For detailed information on the measuring set-up, please contact ebmpapst. Suction-side noise levels: LwA measured as per ISO 13347 / LpA measured with 1m distance to fan axis. The values given are valid under the measuring conditions mentioned above and may vary according to the actual installation situation. With any deviation from the standard set-up, the specific values have to be checked and reviewed with the unit installed.

Measured values

	U	f	n	P _{ed}	I	LpA _{in}	LwA _{in}	q _v	p _{fs}	q _v	p _{fs}
	V	Hz	min ⁻¹	W	A	dB(A)	dB(A)	m ³ /h	Pa	cfm	inH ₂ O
1	230	50	1750	68	0.60	63	69	455	0	270	0.00
2	230	50	1835	60	0.53	60	67	385	100	225	0.40
3	230	50	1960	50	0.46	59	65	305	200	180	0.80
4	230	50	2095	40	0.37	58	64	210	250	125	1.00

U = Supply voltage · f = Frequency · n = Speed (rpm) · P_{ed} = Power input · I = Current draw · LpA_{in} = Sound pressure level inlet side · LwA_{in} = Sound power level inlet side · q_v = Air flow
p_{fs} = Pressure increase

