

G2E160-AY50-97

AC centrifugal fan

forward curved, single inlet

with housing (flange)



G2E160-AY50-97 ebmpapst Datasheet

sales@fansco.com

www.fansco.com

Limited partnership · Headquarters Mulfingen
County court Stuttgart · HRA 590344

General partner Elektrobau Mulfingen GmbH · Headquarters Mulfingen
County court Stuttgart · HRB 590142

Nominal data

Type	G2E160-AY50-97	
Motor	M2E068-EC	
Phase		1~
Nominal voltage	VAC	230
Frequency	Hz	50
Type of data definition		ml
Valid for approval / standard		CE
Speed (rpm)	min ⁻¹	2280
Power input	W	270
Current draw	A	1.18
Motor capacitor	µF	6
Capacitor voltage	VDB	400
Capacitor standard		S0 (CE)
Min. back pressure	Pa	100
Min. ambient temperature	°C	-25
Max. ambient temperature	°C	60
Starting current	A	4.0

ml = Max. load · me = Max. efficiency · fa = Running at free air · cs = Customer specs · cu = Customer unit
Subject to alterations

Data according to ErP directive

	Actual	Request 2015	
01 Overall efficiency η_{es}	%	32.6	32.6
02 Measurement category	A		
03 Efficiency category	Static		
04 Efficiency grade N	44	44	
05 Variable speed drive	No		

Data definition with optimum efficiency.
The ErP data is determined using a motor-impeller combination in a standardised measurement configuration.

09 Power input P_e	kW	0.16
09 Air flow q_v	m ³ /h	355
09 Pressure increase p_{fs}	Pa	518
10 Speed (rpm) n	min ⁻¹	2725
11 Specific ratio*		1.01

* Specific ratio = $1 + p_{fs} / 100\,000\text{ Pa}$

LU-140170



G2E160-AY50-97

AC centrifugal fan

forward curved, single inlet
with housing (flange)

Technical features

Mass	4 kg
Size	160 mm
Surface of rotor	Uncoated
Material of impeller	Sheet steel, galvanised
Housing material	Die-cast aluminium
Direction of rotation	Clockwise, seen on rotor
Type of protection	IP 44; Depending on installation and position as per EN 60034-5
Insulation class	"F"
Humidity (F)/environmental protection class (H)	H0 - dry environment
Max. permissible ambient motor temp. (transp./ storage)	+ 80 °C
Min. permissible ambient motor temp. (transp./storage)	- 40 °C
Mounting position	Shaft horizontal or rotor on bottom; rotor on top on request
Condensate discharge holes	Rotor-side
Operation mode	S1
Motor bearing	Ball bearing
Touch current acc. IEC 60990 (measuring network Fig. 4, TN system)	< 0.75 mA
Motor protection	Thermal overload protector (TOP) wired internally
Cable exit	Variable
Protection class	I (if protective earth is connected by customer)
Product conforming to standard	EN 60335-1; CE
Approval	UL 1004-1; CSA C22.2 No.100



AC centrifugal fan

forward curved, single inlet
with housing (flange)

Product drawing

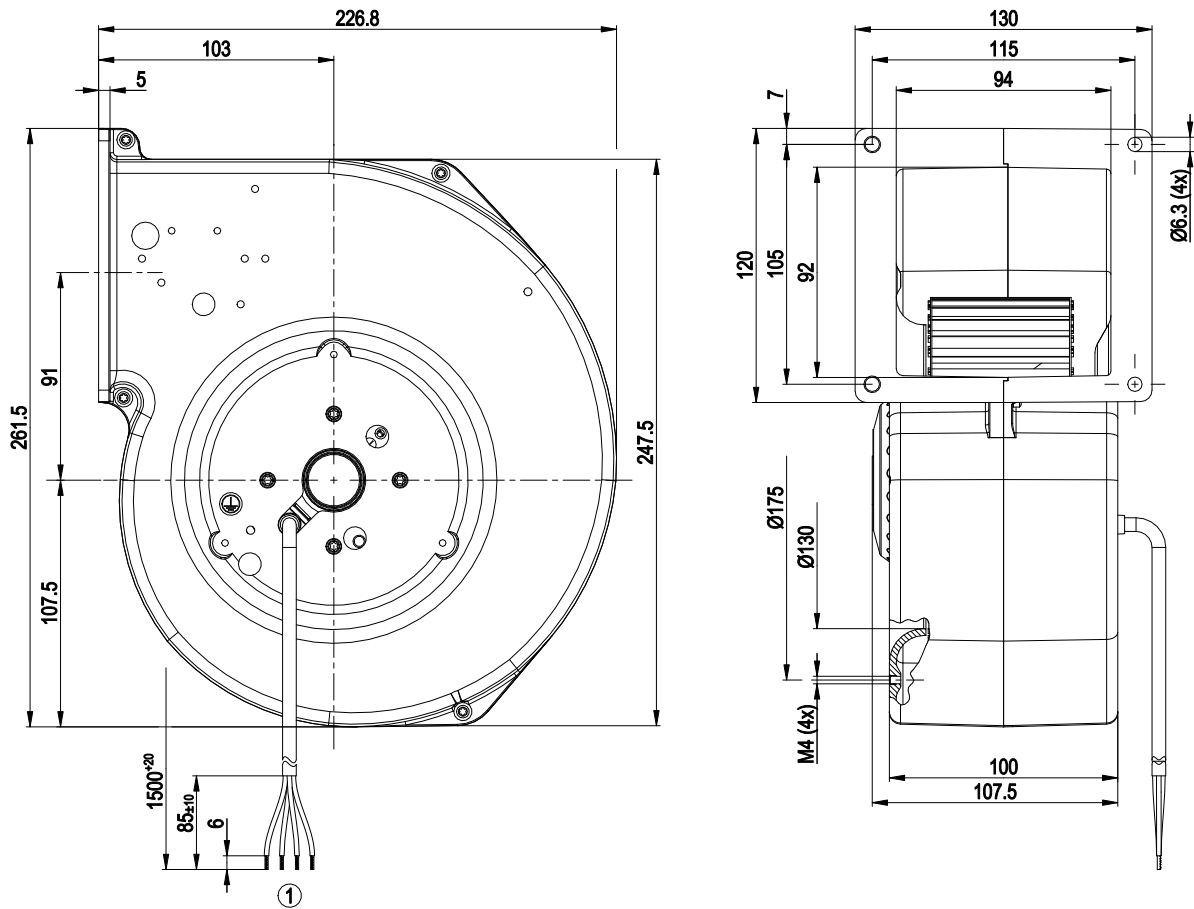

1 Connection line PFA AWG20 (green/yellow AWG18), 4x lead tips crimped

Connection screen

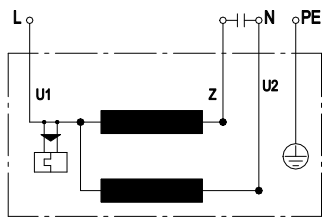

U1	blue	Z	brown	U2	black
PE	green/yellow				



AC centrifugal fan

forward curved, single inlet
with housing (flange)

Charts: Air flow 50 Hz

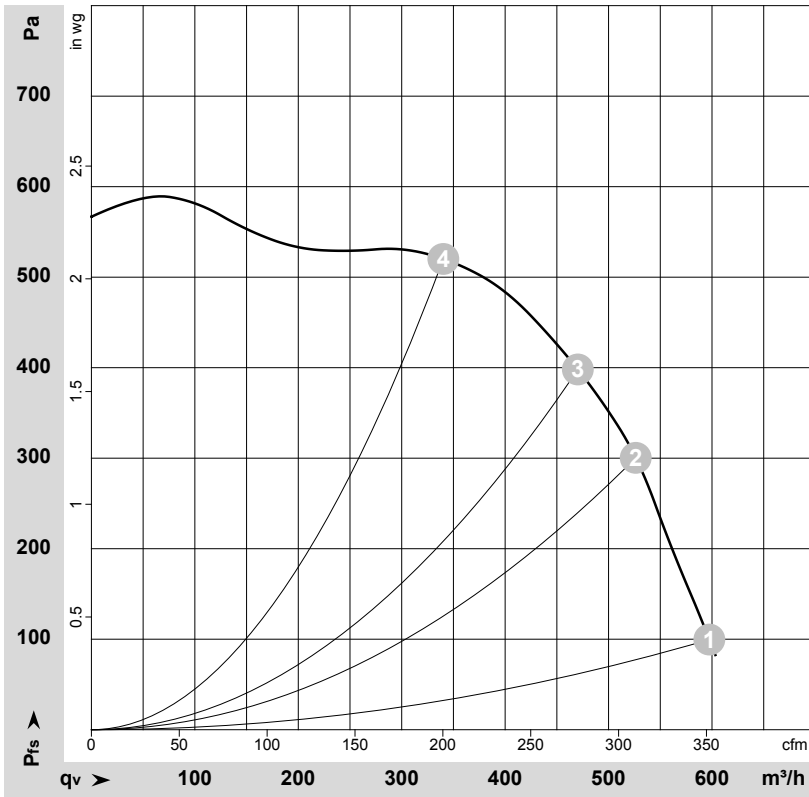

$\rho = 1.15 \text{ kg/m}^3 \pm 2 \%$

Measurement: LU-140170-1

Air performance measured as per ISO 5801 Installation category A. For detailed information on the measuring set-up, please contact ebmpapst. Suction-side noise levels: LwA measured as per ISO 13347 / LpA measured with 1m distance to fan axis. The values given are valid under the measuring conditions mentioned above and may vary according to the actual installation situation. With any deviation from the standard set-up, the specific values have to be checked and reviewed with the unit installed.

Measured values

	U	f	n	P _e	I	q _v	P _{fs}	q _v	P _{fs}
	V	Hz	min ⁻¹	W	A	m ³ /h	Pa	cfm	inH2O
1	230	50	2280	270	1.18	595	100	350	0.40
2	230	50	2485	226	0.98	525	300	310	1.20
3	230	50	2580	202	0.88	470	400	275	1.61
4	230	50	2730	159	0.69	340	520	200	2.09

U = Supply voltage · f = Frequency · n = Speed (rpm) · P_e = Power input · I = Current draw · q_v = Air flow · P_{fs} = Pressure increase

